



## **PROJECT COMPLETION REPORT**

1. **Project Number** : 8239
2. **Title of the Project** : Development of cost effective ventilator
3. **Funding Agency Name** : TRC (DST)
4. **Project Reference Number provided by the Funding Agency:** 8239
5. **Principal Investigator (Name & Address) :**Nagesh D S, SCTIMST
6. **Co-Investigators (Name & Address):**  
Mr.Sarath S.Nair  
Mr.Vinodkumar.V  
Dr.Manikandan.S  
Mr.Manoj.C.S  
  
All from SCTIMST
7. **Implementing Institution:** SCTIMST
8. **Collaborating Institutions** : Nil
9. **Date of Commencement** : 25<sup>th</sup> May 2020
10. **Duration** : 8 months
11. **Date of Completion** : 7<sup>th</sup> June 2021
12. **Objectives as approved :**

To develop a simple, compact, reliable, and cost-effective general-purpose ventilator for adult and pediatric use, up to POC level on fast track mode.  
The proposal doesn't aim at full validation, which will be done with the industry as the next phase.

13. Deviation made from original objectives if any, while implementing the project and reasons thereof :

Nil

14. Field/Experimental work giving full details of summary of methods adopted, data collected supported by necessary tables, charts, diagrams and photographs :

The basic block diagram of the equipment is given below:

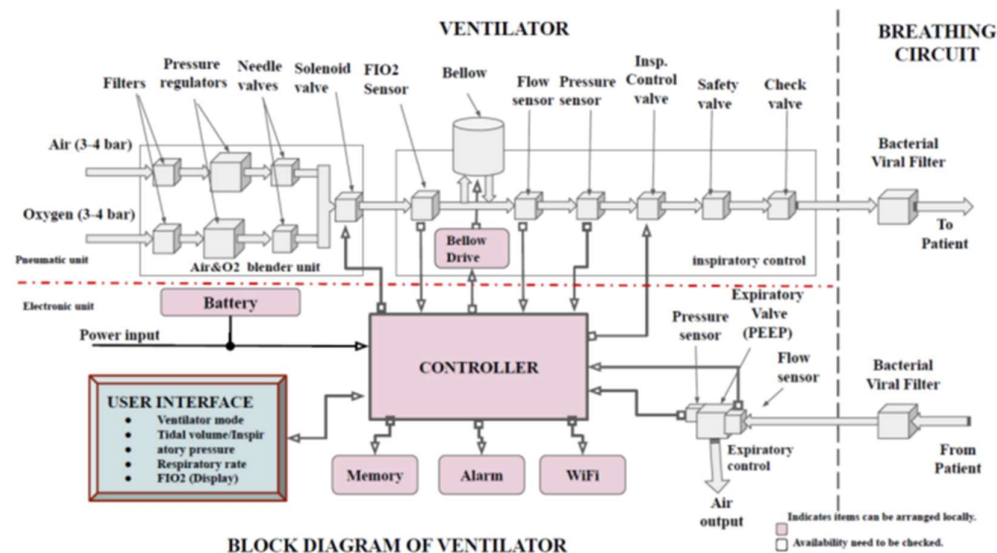

The proposed design is to replace the bellow with a BLDC motor/fan assembly which will make the device simpler and compact.

The methodology and stages of development are:

- Turbine system development to replace the bellow
- Custom design of the blender
- Incorporation of sensors and controls
- Software development
- Integration of all subsystems
- Bench top testing of the full system

15. Detailed analysis of results :

Various features and operating modes at par with the commercially available device is developed and tested as per international standards.

16. Summary sheet of not more than 2 pages under the following heads: (Title, Introduction, Rationale, Objectives, Methodology, Results, Translational Potential)

**Title:** Development of low-cost portable ICU ventilator

**Introduction:**

In early December 2019, an outbreak of a new virus called severe acute respiratory syndrome coronavirus 2 (SARS-CoV-2) in Wuhan, China, shook the world, although the exact date is now

considered questionable. The world today is going through a phase where concern about the spread of the Coronavirus is growing. These viruses affect the respiratory tract of the infected person, and they may get severe breathing difficulties. The level of oxygen intake thus reduces which results in lowering the saturation pressure of oxygen (SpO<sub>2</sub>) in their blood. If not treated timely, the results may be fatal as well. Normally, these patients undergo treatment with forced oxygen support either through high-flow oxygen therapy or by assisting their breathing using a mechanical ventilator. However, these ventilators are very complex and are very costly. The high price of these ventilators are mostly attributed to the lack of knowledge as well as indigenous development in the particular domain. The ICU ventilators cannot be usually used in ambulatory environments or transport conditions and hence need separate units.

**Objective:** Hence the objective was to develop a cost-effective portable ICU ventilator that can be portable and also contains all the necessary features available in a conventional ICU ventilator.

**Methodology:** The technology, systems, and subsystems are developed to obtain a cost-effective ventilator with the following design components.

**General features:**

Turbine based design  
Simple, compact and weighing about 2- 3 kg  
Mainly for portable applications  
Knob controlled with bare minimum software  
LCD Monitor  
10" Tablet display with blue tooth interface  
Can be mounted on any typical pole

**Ventilation modes:** Volume

Controlled and Pressure Controlled  
SIMV, Assist  
CPAP  
Non-Invasive ventilation

The design and development of various subsystems such as inspiratory circuit, expiratory circuit, diagnostics, display, and FiO<sub>2</sub> management are carried out and integrated to a single ventilator chasis.

**17. Contributions made towards increasing the state of knowledge in the subject :**

A portable, cost-effective ventilator is made with necessary features as that of a conventional ICU ventilator with state of the art novel FiO<sub>2</sub> control mechanism.

**18. Conclusions summarising the achievements and indication of scope for future work :**

Prototypes of low-cost portable ventilator is developed and proof of concept is established through Invitro tests as shown in the figure below.



Various features and operating modes at par with commercially available device is developed and tested as shown below.

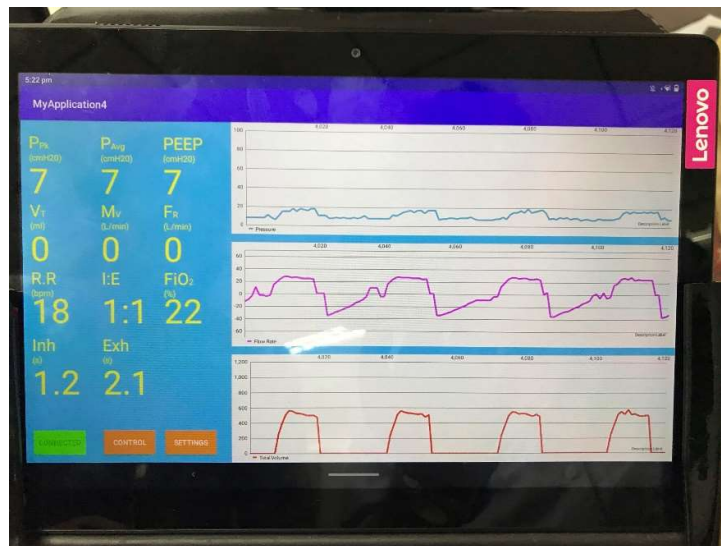

Further tests may be carried out by industry for scale-up and commercialization.

**19. Science and Technology benefits accrued :**

**a. List of research publications with complete details :**

Nil

**b. Manpower trained on the project :**

i. Research Scientists or Research Fellows : 0

ii. No. of PhD's produced : 0

iii. Other Technical Personnel trained :

c. Patents taken, if any : Patent : Application  
202141048525 (IPECD217.Y21)

Device for Contactless adjustment of proportion of gases particularly for management of FiO<sub>2</sub>

d. **Products developed, if any** : Portable ICU Ventilator

20. **Abstract: (In 300 words for possible publication in ..... Bulletin)**

a. **Background:** Patients with chronic respiratory illness undergo treatment with forced oxygen support either through high-flow oxygen therapy or by assisting their breathing using a mechanical ventilator. However, these ventilators are very complex and are very costly. The high price of these ventilators are mostly attributed to the lack of knowledge as well as indigenous development in the particular domain. The ICU ventilators cannot be usually used in ambulatory environments or transport conditions and hence need separate units.

b. **Materials:** Various.

c. **Results:** Various features and operating modes at par with commercially available device is developed and tested.

d. **Conclusion:** Prototypes of low-cost portable ventilator is developed and proof of concept is established through Invitro tests

21. **Procurement/Usage of Equipment: No Equipment purchased**

a. **Details of Equipment:**

Sl. No.	Name of Equipment	Make/ Model	Cost (Rs.)	Date of Installation	Utilisation	Remarks regarding maintenance breakdown

b. **Suggestions for disposal of equipment(s):**  
NA

(Name and Signature of PIs with date)

**Routing:** Signed copy of "Project completion Report" by PI → [root@sctimst.ac.in](mailto:root@sctimst.ac.in), [rpc@sctimst.ac.in](mailto:rpc@sctimst.ac.in)