

From,  
Dr. Dinoop K. P.,  
Associate Professor – Clinical Microbiology,  
Department of Microbiology,  
SCTIMST, Thiruvananthapuram.

Date: 24.11.2022

To,  
Dr. Nivedita Gupta,  
Scientist F & Head,  
ECD-I, ICMR Headquarters,  
Ansari Nagar, New Delhi

**SUB:** Submission of final report along with the 2<sup>nd</sup>/final year Statement of Expenditure (SE) & audit certificate for the ICMR Extramural Adhoc project (File no: OMI/6/2020-ECD-I), for approval and release of the 2<sup>nd</sup> instalment (Rs. 90540) of the 2<sup>nd</sup>/final year fund : Reg.

Respected Madam,

Greetings from SCTIMST, Trivandrum. Herewith submitting the final report (in quintriplicates) as requested in the ICMR letter (File no: OMI/6/2020-ECD-I dated 01.11.2022) along with the 2<sup>nd</sup>/final year audited statement of expenditure (SE) and utilization certificate (UC) for the Indian Council of Medical Research (ICMR)-Extramural Adhoc funded project [P-5410] titled "A prospective cohort study on cerebrospinal fluid (CSF) diversion catheter-related infections in a tertiary referral neurosurgical care center". Alongwith attached is the list of non-expendable & expendable articles with property details (In duplicates) and our request to you to grant consent for retention of these articles for future research work at SCTIMST. Approval of the council shall be sought when its proposed to publish the scientific content in any foreign journal and due acknowledgement to Indian Council of Medical Research (ICMR) will be made in all publications and presentations arising from this scientific content. I request you to kindly examine the attached audited SE-UC report for approval of the release of the 2<sup>nd</sup> instalment of the 2<sup>nd</sup>/final year fund. Many thanks to you and the ICMR-ECD team for the constant support and timely communications.

Thanking you.

Yours sincerely,

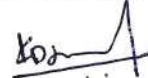

Dr. Dinoop K.P.  
Principal Investigator (PI),  
Project No: OMI/6/2020-ECD-I.

**Dr. DINOOP K. P.**  
**Associate Professor - Clinical Microbiology**  
**Department of Microbiology**  
**Sree Chitra Tirunal Institute for**  
**Medical Sciences & Technology (SCTIMST)**  
**Thiruvananthapuram - 695011, Kerala, India**  
**KSMC Reg. No: 72406**

**Attachments:**

1. Statement of expenditure (SE) & utilisation certificate (UC)
2. List of purchased expendable and non-expendable articles (In duplicate)
3. Final report with annexures 1-4 (In quintriplicates)





**SREE CHITRA TIRUNAL INSTITUTE FOR MEDICAL SCIENCES & TECHNOLOGY  
TRIVANDRUM – 695011**

**Statement of Accounts  
(Period 28.10.2020 TO 27.10.2022)**

1. Sanction Letter No. : OMI/6/2020-ECD-1
2. Total Project Cost (I and II Year) : Rs. 2134504
3. Sanction /Revised Project cost (if applicable): N A
4. Date of Commencement of Project : 28.10.2020
5. Proposed Date of Completion : 27.10.2022
6. Statement of Expenditure : From 28.10.2020 to 27.10.2022

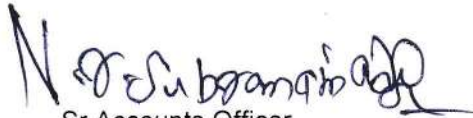
SI No	Head	Funds Allocated (1 <sup>st</sup> & 2 <sup>nd</sup> Year)	Expenditure Incurred		Balance as on 27.10.2022	Remarks
			I Year	II Year		
A	Staff	1201800	404214	563663	233923	Re-appropriation of unspent balance from the Heads Staff Salary, Non-recurring contingency and Travel to recurring contingency head is made as per ICMR approval dated 08.04.2021 and 23.08.2022.
B. Contingency						
B.1.	Non-recurring (Equipments)	189000	153563	0.00	35437	
B.2	Recurring	456460	623223	318137	(-) 484900	
C.	Travel	125000	0.00	0.00	125000	
D.	Overhead	71704	48100	23604	0.00	
<b>Total</b>		<b>2043964</b>	<b>1229100</b>	<b>905404</b>	<b>(-) 90540</b>	

  
 Sr Accounts Officer  
 Date: 24.11.2022  
**N. VENKITA SUBRAMANIA IYER**  
 Sr. ACCOUNTS OFFICER  
 Sree Chitra Tirunal Institute for  
 Medical Sciences and Technology  
 Thiruvananthapuram

  
 Principal Investigator  
 Proj # 5410

**Dr. DINOOP K. P.**  
 Associate Professor - Clinical Microbiology  
 Department of Microbiology  
 Sree Chitra Tirunal Institute for  
 Medical Sciences & Technology (SCTIMST)  
 Thiruvananthapuram - 695011, Kerala, India  
 KSMC Reg. No: 72406



K

**SREE CHITRA TIRUNAL INSTITUTE FOR MEDICAL SCIENCES & TECHNOLOGY  
TRIVANDRUM – 695011**

**Check list for covering note to accompany Utilization Certificate of  
grant for the project for the period from 28.10.2021 to 27.10.2022**

1.	Title of the project	"A prospective cohort study on cerebrospinal fluid (CSF) diversion catheter related infections in a tertiary referral neurosurgical care center"
2	Name of the Institution	Sree chitra Tirunal Institute for medical Sciences and Technology, Trivandrum
3	Principal Investigator	Dr Dinoop K P, Associate Professor, Microbiology Dept SCTIMST
4	ICMR letter No. and date sanctioning the project.	OMI/6/2020-ECD-1 dated 08.10.2020
5	Head of account as given in the original sanction letter	
6	Amount received during the year (Please give No. & Date of ICMR's sanction letter for the amount and period)	Rs. 814864/- OMI/6/2020-ECD-1 dated 17.03.2022
7	Total amount that was available for expenditure (excluding commitments) during the year (Sl.No.6+7)	Rs 814864/-
8	Actual expenditure (excluding commitments) incurred during the year.	Rs. 905404/-
9	Balance amount available at the end of the year, ie as on 27.10.2021	Rs (-) 90540/-
10	Amount already committed, if any.	Rs. (-) 90540/-
11	Amount to be carried forward to the next year (if applicable). Indicate the amount already committed with supporting documents.	Rs 0.00

2

Utilization Certificate

Certified that out of **Rs. 814864.00 (Rupees Eight Lakh Fourteen Thousand Eight Hundred and Sixty Four only)** of grants-in-aid sanctioned during the year 2021-22 in favour of Director, SCTIMST under ICMR Letter No. OMI/6/2020-ECD-1 dated 17.03.2022, and out of unspent balance of the previous year **Rs. 0.00** a sum of **Rs. 905404.00 (Rupees Nine Lakh Five Thousand Four Hundred and Four Only)** has been utilized for the purpose of "A prospective cohort study on cerebrospinal fluid (CSF) diversion catheter related infections in a tertiary referral neurosurgical care center", and that the balance of (-) **Rs.90540.00 (Rupees Ninety Thousand Five Hundred and Forty only)** remaining to be received from ICMR at the end of 27.10.2022 has been surrendered to ICMR (vide cheque No .....NIL..... Dated.....NIL.....) will be adjusted towards the grants-in-aid payable during the next year i.e. 2021-22.

  
Sr. Accounts Officer  
Date 24.11.2022

**N. VENKITA SUBRAMANIA IYER**  
Sr. ACCOUNTS OFFICER  
Sree Chitra Tirunal Institute for  
Medical Sciences and Technology  
Thiruvananthapuram

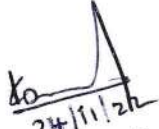
  
24/11/22  
Principal Investigator  
Proj # 5410

**Dr. DINOOP K. P.**  
Associate Professor - Clinical Microbiology  
Department of Microbiology  
Sree Chitra Tirunal Institute for  
Medical Sciences & Technology (SCTIMST)  
Thiruvananthapuram - 695011, Kerala, India  
KSMC Reg. No: 72406

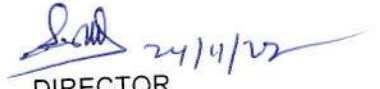
  
24/11/22  
DIRECTOR  
SCTIMST

निदेशक / DIRECTOR  
श्री चित्रा तिरुनाल आयुर्विज्ञान और प्रौद्योगिकी संस्थान  
Sree Chitra Tirunal Institute for  
Medical Sciences and Technology  
त्रिवेन्द्रम / Trivandrum-695011



## FINAL REPORT

1. **Title of the project:** A prospective cohort study on cerebrospinal fluid (CSF) diversion catheter-related infections in a tertiary referral neurosurgical care centre.

2. **Unique ID of the project:** File No. OMI/6/2020-ECD-I

3. **Principal Investigator and Co-investigators**

**Principal Investigator (Name & address):**

Dr. Dinoop K. P., Associate Professor – Clinical Microbiology, Department of Microbiology, Sree Chitra Tirunal Institute for Medical Sciences & Technology (SCTIMST), Thiruvananthapuram - 695011, Kerala, India.

Mobile: +91 9486199476; Phone: 0471-2524502 (Off.);0471-2595284 (Home).

Email ID: [drdinukp@sctimst.ac.in](mailto:drdinukp@sctimst.ac.in); [drdinukp@gmail.com](mailto:drdinukp@gmail.com)

**Co-Investigators (Name & address):**

- I. Dr. Ganesh Divakar, Assistant Professor, Department of Neurosurgery, Sree Chitra Tirunal Institute for Medical Sciences & Technology (SCTIMST), Thiruvananthapuram - 695011, Kerala, India.  
Mobile: +91 9447095720; Phone: 0471-2524646 (Off.).  
Email ID: [gd@sctimst.ac.in](mailto:gd@sctimst.ac.in)
- II. Ms. Shiny Biju, Infection Control Nurse, Hospital Infection Control Unit (HICU), Sree Chitra Tirunal Institute for Medical Sciences & Technology (SCTIMST), Thiruvananthapuram - 695011, Kerala, India.  
Mobile: +91 9495904564; Phone: 0471-2524216 (Off.).  
Email ID: [hicu@sctimst.ac.in](mailto:hicu@sctimst.ac.in)
- III. Dr. Kavita Raja, Professor – Senior Grade & Head, Department of Microbiology, Sree Chitra Tirunal Institute for Medical Sciences & Technology (SCTIMST), Thiruvananthapuram - 695011, Kerala, India.  
Mobile: +91 9847400913; Phone: 0471-2524222 (Off.).  
Email ID: [kavita\\_raja@sctimst.ac.in](mailto:kavita_raja@sctimst.ac.in)
- IV. Dr. Mathew Abraham, Professor, Department of Neurosurgery, Sree Chitra Tirunal Institute for Medical Sciences & Technology (SCTIMST), Thiruvananthapuram - 695011, Kerala, India.  
Mobile: +91 9645001623; Phone: 0471-2524647 (Off.).  
Email ID: [mathew@sctimst.ac.in](mailto:mathew@sctimst.ac.in)

4. **Implementing Institution:**

Sree Chitra Tirunal Institute for Medical Sciences & Technology (SCTIMST).

No collaborating Institutions in this project

5. **Date of commencement:** 28.10.2020

6. **Duration:** 2 years

7. **Date of completion:** 27.10.2022

8. **Objectives as approved:**

- I. Determine the incidence of device-associated CNS infections following various CSF-diversion procedures.
- II. Identify the associated risk factors
- III. Analyze their outcomes
- IV. Evaluate novel CSF biomarkers and cytokines in its early diagnosis
- V. Identify risk-reduction strategies to develop evidence-based best practice care bundles.

9. Deviation made from original objectives if any, while implementing the project and reasons thereof

There were no deviations from the original objectives

10. Field/Experimental work giving full details of summary of methods adopted, data collected supported by necessary tables, charts, diagrams and photographs:

**(Includes Annexure 1: Standard Operating procedure for testing CSF biomarkers and for operating equipments/instruments)**

I. **Study Design:** Single-center, prospective, observational, cohort study.

II. **Project Implementation plan:**

Patients were recruited from the inpatient wards/ICU of Department of Neurosurgery, SCTIMST, Thiruvananthapuram, Kerala, India.

Inclusion criteria:

1. All patients who underwent neurosurgical procedure of CSF diversion (Permanent – ventriculoperitoneal, lumboperitoneal and ventriculoatrial shunts or Temporary – External ventricular drain and lumbar drain)
2. With device insitu for >24 hours
3. With clinical suspicion of meningitis (unexplained fever and/or deterioration in sensorium)

Exclusion criteria:

1. CSF diversion procedures performed in a patient with a documented pre-existing CNS infection.
2. Patients in immunocompromised status (Neutropenia: Absolute neutrophil count < 500/ $\mu$ L)

The principal and co-investigators recruited the study participants. Patients satisfying the inclusion/exclusion criteria were included in the study, after obtaining written consent.



Classification of patients based on Case definitions  
2017 Infectious Diseases Society of America (IDSA) clinical practice guidelines for Health  
care-associated ventriculitis and meningitis



Data was collected from the electronic medical records (EMR) of SCTIMST  
CSF was collected from the sample collection port for EVD/lumbar drains OR from the  
sampling reservoir/chamber for permanent CSF shunts (if available) for Gram staining,  
microbial culture and estimation of biomarker levels. When sampling reservoir/chamber was  
not available, CSF sample collected by lumbar puncture (collected for diagnosis of  
meningitis/ventriculitis) was used for testing.

An additional 1 ml of CSF sample was collected for biomarker estimation for archiving at -  
20°C (CSF: lactate, procalcitonin, IL-10/17A and IL-1 $\beta$  levels). This additional sample amount  
was collected during specimen collection for routine procedures [1. CSF cytology, Gram  
stain/culture and biochemical analysis (glucose/protein): at device insertion and further every  
24-48 hours]

Organism identification was performed using VITEK 2 compact system and antibiotic  
susceptibility testing by Kirby-Bauer Disc diffusion test and MIC determination by E-test &  
VITEK 2 compact system.

CSF biomarker levels was estimated at 48-hour intervals, in samples sent to the microbiology  
laboratory for routine bacterial culture. Blood sample (Biomarker estimation) was collected in  
sample collections without anticoagulant and immediately transported to the Microbiology  
Laboratory. The serum was separated by centrifugation at 3000g x 20 minutes.

Quantitative estimation of biomarkers: 1. Procalcitonin (PCT) – Chemiluminescence assay  
[ARCHITECT B.R.A.H.M.S PCT, Abbott Diagnostics Abbott Park, Illinois, U.S.A] (OR)  
ELFA [VIDAS® B.R.A.H.M.S PCT assay (bioMérieux, Marcy L'Etoile, France] and 2.  
Interleukins: IL-10/17A and IL-1 $\beta$  – Quantitative ELISA (qELISA), at Department of  
Microbiology, SCTIMST 3. Lactate [ARCHITECT Clinical chemistry,  
Abbott Diagnostics Abbott Park, Illinois, U.S.A]

#### **(Annexure 1 – Standard Operating Procedure)**



Statistical analysis of data

IHI comprehensive flowchart used for designing EVD & LD care bundle

## **Surveillance of Device-associated CNS Infections**

The surveillance was performed by the research assistant, infection control nurse (ICN) and the link nurses in the neurosurgery department. The numerator (Number of patients with infection based on IDSA criteria) was collected by the investigators and ICN, while the device days (denominator) entered by the link nurses was collected from the hospital information system (HIS) by the research assistant. e.g. ERI (EVD-related infection) rate = No of patients with infection/Number of EVD days X 1000 (ERI rate is expressed as per 1000 EVD days)

### **CSF laboratory parameters used in the case definition of device-associated ventriculitis/meningitis:**

CSF glucose/serum glucose – Ratio <0.5 OR/AND

CSF cell index- CSF WBC/RBC ratio divided by blood WBC/RBC ratio of >5

### **List of biomarkers testing in the study:**

CSF lactate (Inflammation and anaerobic metabolism), CSF procalcitonin, CSF presepsin, CSF IL-10/IL-17A and CSF IL-1 $\beta$  (Markers of bacterial infection)

### **Data collection tool:**

Was used for collection of details of patient demographics, surgical factors (pre-operative, operative and post-operative), clinical features, laboratory parameters, treatment and their outcomes.

### **Statistical analysis:**

Descriptive statistics – Will be expressed as frequencies and percentages for categorical variables, median and interquartile range for continuous variables. Incidence will be expressed as mean with 95% confidence interval.

Univariate analysis – Chi-square or Fischer exact test will be used to compare clinical variables between infected and non-infected cases. Multivariate logistic regression analysis will be used to calculate the odds ratio or hazard risk.

Nelson-Aalen cumulative hazard estimate and Kaplan-Meier survival analysis curves will be analysed for the risk variables.

Optimal cut-off value for the biomarkers will be determined using the Receiver Operating Characteristic (ROC) curve.

A p value of <0.05 will be taken as statistical significance. Bonferroni correction will be undertaken for multiple factor comparisons.

Analysis Software [Addinsoft (2022); XLSTAT statistical and Life Sciences data analysis solution, version 2022.4.1; New York, USA] was used for statistical analysis.

Institute for Healthcare Improvement (IHI) comprehensive flowchart used for designing the external ventricular drain (EVD) and lumbar drain (LD) care bundle.

**11.** Detailed analysis of results: **Annexure 2**

**12.** Summary sheet of not more than 2 pages under following heads (Title, Introduction, Rationale, Objectives, Methodology, Results, Translational potential): **Annexure 3**

**13.** Contributions made towards increasing the state of knowledge in the subject.

- I.** Identification of the rates, risk factors and potential outcomes of the various device-associated CNS infections following CSF diversion procedures.
- II.** Development of drain care bundles for prevention of health-care associated ventriculitis/meningitis.
- III.** Evaluation of the diagnostic parameters of novel CSF biomarkers in early diagnosis of device-associated CNS infections and contribute to early diagnosis which is difficult with the conventional laboratory markers and assays.

**14.** Conclusions summarising the achievements and indication of scope for future work

- I.** The generated pilot data will be used for initiating future studies
  - A.** Multicentric study involving various tertiary referral neurosurgical centres across India, to initiate randomised controlled trials (RCT) to evaluate the proposed evidence-based care bundle, and further the role of CSF therapeutic drug monitoring (TDM) to guide intravenous and intraventricular delivery of antibiotics and guide management of device-associated CNS infections.
  - B.** Technology development programme in collaboration with the Biomedical technology wing of the Institute [Designated as Technical Research Centre (TRC) for Biomedical devices by the Department of Science and Technology (DST) for development of
    - a)** Cost-effective and efficacious rapid In-Vitro Diagnostics (IVD) in detection of the studied cerebral metabolites as biomarkers in early diagnosis of device-associated CNS infections and

b)Development of coated/impregnated catheters (with antimicrobial/antibiofilm compounds) in prevention of device-associated CNS infections in developing countries where the epidemiology differs from developed countries. The currently available rifampicin/minocycline antimicrobial-coated catheters in the market globally only address the prevention of colonisation and biofilm formation of Gram-positive bacteria predominantly while the epidemiology of device associated CNS infections in low and middle income countries (LMIC) is predominantly caused by multi-drug resistant (MDR) Gram-negative bacteria.

## 15. Science and Technology benefits accrued

### A. List of research publications with complete details:

Manuscript preparation in process. No publications yet.

ICMR consent will be sought prior to submission of manuscripts to international journals for publication. Due acknowledgement to ICMR will be made in all manuscripts submitted for publications (National and International)

### **2 Paper presentations in International conferences**

- I. European Congress of Clinical Microbiology and Infectious Diseases (ECCMID) – 2022, Lisbon, Portugal (Hybrid); Title of paper: Clinico-microbiological profile of cerebrospinal fluid (CSF) diversion catheter-related infections from a tertiary referral neurosurgical care center in South India
- II. Federation of Infection Societies (FIS) – Healthcare Infection Society (HIS) 2022 International Conference, London, Title of the paper: Evaluation of novel cerebrospinal fluid (CSF) biomarkers as an early diagnostic tool in device-associated ventriculitis/meningitis: A prospective observational cohort study from a quaternary referral neurosurgical care centre in India.

### B. Manpower trained on the project

- a. Research Scientists or Research Fellows: 1 (One)
- b. No. of PhD's produced: Nil
- c. Other Technical Personnel trained: Lab technician – 1 (One)

### C. Patents taken, if any: Nil (Not yet)

### D. Products developed, if any: Nil (Not yet)

## 16. Abstract (300 words for possible publication in ICMR Bulletin)

### **Background:**

CSF diversion catheter-related infections (CDRI) is a major subgroup of health-care associated CNS infections occurring due to contamination or colonization of a temporary and permanently implanted neurosurgical device.

### **Materials:**

This was a single center 2-year (October 2020-September 2022) prospective cohort observational study. Patients were categorised using IDSA criteria as Contamination or Colonisation or Infection. Patient data was collected from the electronic medical records (EMR) and Device days were also collected from the Hospital information system (HIS). CSF samples were collected for estimation of various novel biomarkers and data was collected from the electronic medical records. Receiver Operating Characteristic (ROC) curve analysis was performed to determine the diagnostic efficiency and optimal cut-off threshold for the various biomarkers. Institute for healthcare improvement (IHI) comprehensive flowchart was used to design external ventricular drain (EVD) and lumbar drain (LD) care bundles

### **Results:**

A total of 35 CSF diversion catheter-related infections (CDRI) were diagnosed (15 involving EVD, 11 involving LD, 8 involving VP shunts and 1 involving LP shunt. The average rate for EVD infection during this 2-year period was 11.12 per 1000 EVD days, while for LD infection was 11.86 per 1000 LD days. The infection rates for VP and LP shunts were 6 and 5.2 per procedure respectively. The most common organism causing CDRI was *Klebsiella pneumoniae* (n=14, 40%), followed by *Acinetobacter baumannii* (n=7, 20%). Estimation of area under the curve (AUC) using ROC curve analysis showed statistical significance ( $p<0.05$ ) for the CSF biomarkers procalcitonin, presepsin, lactate, IL-1beta and Il-17A in diagnosing CDRI. The optimal cut-offs concentration estimated were 0.084 ng/ml, 922 pg/ml, 4.1 mmol/L, 0.270 pg/ml & 5.25 pg/ml respectively.

### **Conclusion:**

This study is first from India to describe the clinico-microbiological characteristics, the diagnostic evaluation of novel biomarkers and proposing EVD/LD care bundles in the diagnosis and prevention of CDRI respectively.

## 17. Procurement/Usage of Equipment:

### A.

S. No	Name of equipment	Make/ Model	Cost FE/Rs	Date of Installation	Utilisation rate %	Remarks regarding maintenance/breakdown
1.	Deep freezer (-20°C) - 1	Cole Parmer, USA	Rs. 153563	15.03.2021	80% (storage capacity being utilised)	The equipment is provided with a warranty period of 3 years and is under annual maintenance contract (AMC)
2.	Research Pipette (Adjustable) – 2 [2-20 µl & 20-200 µl]	Eppendorf, Germany	Rs. 27,300	05.02.2021	100%, For all research sample handling	Functioning well and is calibrated at regular intervals.

### B. Suggestions for disposal of equipment(s)

**Annexure 4:** Request letter (SCTIMST/Projects/MB/P-5410/2022-23/1 dated 21.11.2022) drafted requesting ICMR to kindly grant consent for retention of the equipments/assets for ongoing and future research of the Department of Microbiology and Hospital infection Control Unit (HICU), SCTIMST.

**Title of the project:** A prospective cohort study on cerebrospinal fluid (CSF) diversion catheter-related infections in a tertiary referral neurosurgical care centre.

**ICMR Unique ID of the project:** File No. OMI/6/2020-ECD-I

**Name and Signature with date**

1. **Dr. DINOOP K. P.**  
(Principal Investigator)

  
22.11.2022

2. **Dr. GANESH DIVAKAR**  
(Co-Investigator)

  
22.11.2022

3. **Ms. SHINY BIJU**  
(Co-Investigator)

  
22.11.2022

4. **Dr. KAVITA RAJA**  
(Co-Investigator)

  
22.11.2022

5. **Dr. MATHEW ABRAHAM**  
(Co-Investigator)



  
22.11.2022

# STANDARD OPERATING PROCEDURE (SOP)

Project ID: P-5410

**Title:** A prospective cohort study on cerebrospinal fluid (CSF) diversion catheter-related infections in a tertiary referral neurosurgical care center



**Funding:** ICMR Extramural Adhoc scheme

<b>Prepared By :</b> Ms. Gopika S. L. <b>Designation:</b> Laboratory Technician (P-5410)	<b>Signature:</b> 	<b>Issue Date :</b> 09.07.2021	<b>Page No : 1</b>
<b>Verified By :</b> Dr. Dinoop K. P. <b>Designation:</b> Assistant Professor, Microbiology	<b>Signature:</b> 	<b>Revision No:</b>	<b>Copy no: Controlled</b>
<b>Issued By :</b> Dr. Kavita Raja <b>Designation:</b> Professor & Head, Microbiology	<b>Signature :</b> 	<b>ICMR Extramural Adhoc: P-5410</b>	







## INDEX

<b>A. Procedure manual for biomarker assays</b>	<b>Page no.</b>
1. Estimation of Human IL-1 $\beta$ levels.....	05
2. Estimation of Human IL-17A levels.....	19
3. Estimation of Human procalcitonin (PCT) levels.....	33
4. Estimation of Lactic Acid (LA) levels.....	44
5. Estimation of Human Presepsin (PSP) levels.....	49
<b>B. Operation manual for equipments to estimate biomarker levels</b>	
1. QuantStudio 5 Real-Time PCR Instrument – For IL-1 $\beta$ / IL-17A.....	59
2. B·R·A·H·M·S KRYPTOR compact PLUS for Procalcitonin (PCT).....	68
3. Dimension <sup>®</sup> RXL Max <sup>®</sup> clinical chemistry system for lactic acid (LA)..	91
4. ELx50™ Microplate Strip Washer for Presepsin (PSP) ELISA.....	99
5. ELx 800 Absorbance Reader for Presepsin (PSP) ELISA.....	111

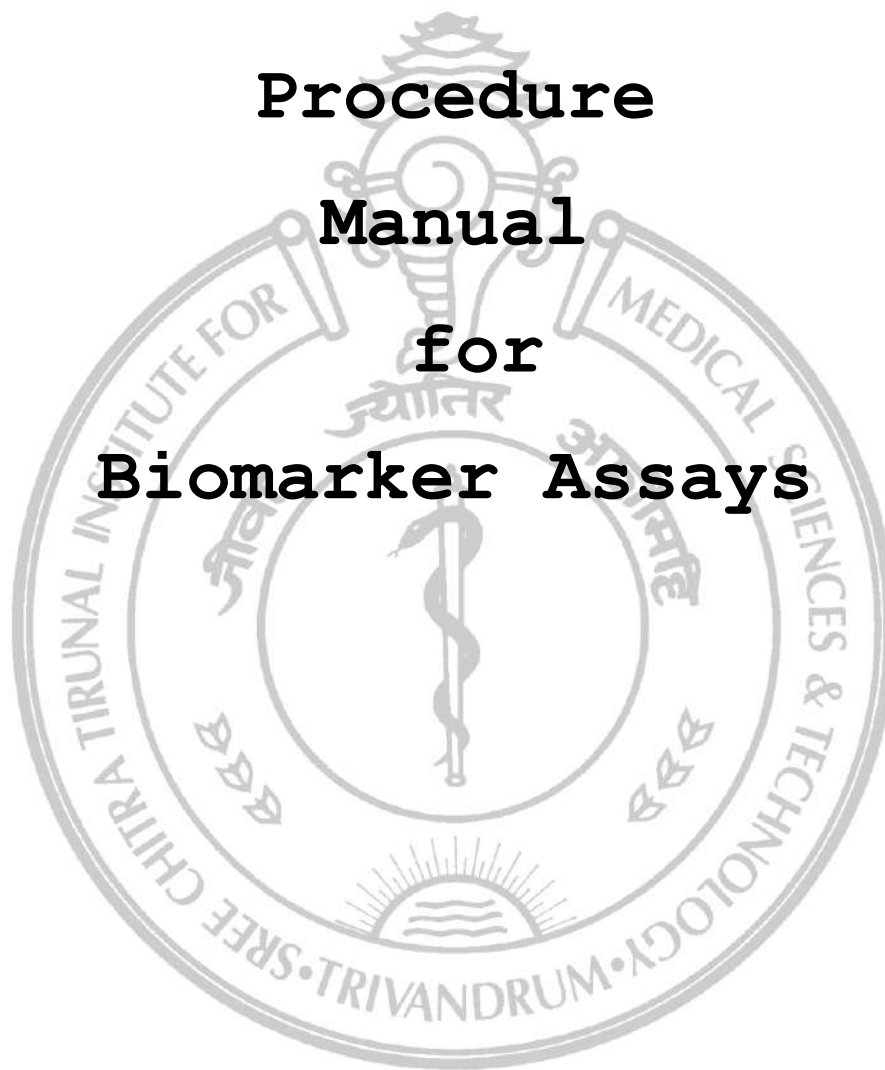
<b>Prepared By :</b> Ms. Gopika S. L. <b>Designation:</b> Laboratory Technician (P-5410)	<b>Signature:</b> 	<b>Issue Date :</b> 09.07.2021	<b>Page No :</b> 3
<b>Verified By :</b> Dr. Dinoop K. P. <b>Designation:</b> Assistant Professor, Microbiology	<b>Signature:</b> 	<b>Revision No:</b>	<b>Copy no:</b> <b>Controlled</b>
<b>Issued By :</b> Dr. Kavita Raja <b>Designation:</b> Professor & Head, Microbiology	<b>Signature :</b> 	<b>ICMR Extramural Adhoc: P-5410</b>	

# Procedure Manual for Biomarker Assays



<b>Prepared By :</b> Ms. Gopika S. L. <b>Designation:</b> Laboratory Technician (P-5410)	<b>Signature:</b> 	<b>Issue Date :</b> 09.07.2021	<b>Page No :</b> 4
<b>Verified By :</b> Dr. Dinoop K. P. <b>Designation:</b> Assistant Professor, Microbiology	<b>Signature:</b> 	<b>Revision No:</b>	<b>Copy no:</b> Controlled
<b>Issued By :</b> Dr. Kavita Raja <b>Designation:</b> Professor & Head, Microbiology	<b>Signature :</b> 	<b>ICMR Extramural Adhoc: P-5410</b>	

## **1. Human IL-1 $\beta$ immunoassay**

### **5.5.3a. Purpose of the examination:**

To provide highly sensitive quantitative measurements of human IL-1 $\beta$  protein in small sample volumes.



### **5.5.3b. Principle and method of examination:**

Utilizing **proximity ligation assay (PLA) technology**, the assay combines the analyte specificity of high-affinity antibody-antigen binding with the signal detection and amplification capabilities of real-time PCR to achieve a simple yet powerful next-generation protein quantitation platform.

**(A) Antibody-antigen binding:** Antibodies bind to two separate epitopes on the antigen (during a 1-hr incubation), which brings the two conjugated oligonucleotides into close proximity.

**(B) Ligation and amplification of signal (in a qPCR instrument):** DNA ligase and a third splint oligonucleotide connector are added to ligate the two ends of the conjugated oligonucleotides, creating a 100-base DNA template. Once the ligase is inactivated at 95°C, the sample is amplified through 40 cycles of annealing and extension. The amount of DNA produced is measured after each amplification cycle via fluorescent dyes, which exhibit fluorescence that is directly proportional to the number of PCR product molecules (or amplicons) generated. This graph shows the fluorescence vs. cycle number curves for four different starting protein concentrations. The dashed line represents the fluorescence threshold. The cycle number required to reach the fluorescence threshold (threshold cycle or Ct) is plotted vs. protein concentration to create a standard curve.

Assay runs on any real-time PCR instrument. ProQuantum immuno assays utilize a matched pair of target-specific antibodies, each conjugated to a DNA oligonucleotide. During antibody-analyte binding, the two DNA oligos are brought into close proximity, which allows for ligation of the two strands and subsequent creation of a template strand for amplification. This

<b>Prepared By :</b> Ms. Gopika S. L. <b>Designation:</b> Laboratory Technician (P-5410)	<b>Signature:</b> 	<b>Issue Date :</b> 09.07.2021	<b>Page No : 5</b>
<b>Verified By :</b> Dr. Dinoop K. P. <b>Designation:</b> Assistant Professor, Microbiology	<b>Signature:</b> 	<b>Revision No:</b>	<b>Copy no: Controlled</b>
<b>Issued By :</b> Dr. Kavita Raja <b>Designation:</b> Professor & Head, Microbiology	<b>Signature :</b> 	<b>ICMR Extramural Adhoc: P-5410</b>	

**Department of Microbiology**  
**Sree Chitra Tirunal Institute for Medical Sciences and Technology (SCTIMST)**

platform leverages the sensitivity and large dynamic range of Applied Biosystems TaqMan real-time PCR technology (Figure1).

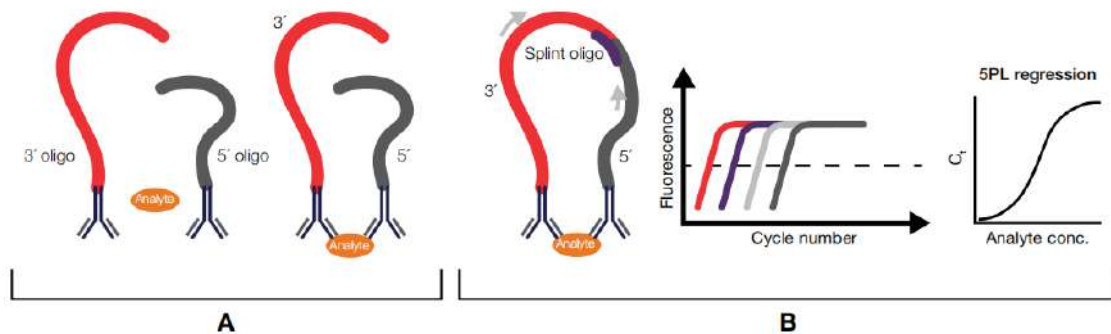

(Figure 1)

**5.5.3c. Procedure of the examination: ProQuantum Human IL-1  $\beta$  immunoassay**

**Guidelines for handling reagents:**

1. Centrifuge vials before pipetting to ensure the contents are at the bottom of the tube.
2. Do not thaw Ligase. Always keep Ligase at  $-20^{\circ}\text{C}$  or on ice. Ligase is viscous. Careful with pipetting accurate amounts and not cause bubbles.
3. Thaw all reagents except Ligase at room temperature.
4. Larger vials like Assay Dilution buffer may take a while to thaw and can be thawed in a warm water bath.
5. Keep Ligase and thawed reagents on ice.
6. Use a refrigerated cold block for the working plate to keep all reagents cool during preparation steps. If a cold block is not available, keep the working plate on ice.
7. If any particulate matter is present in the sample, centrifuge, or filter sample before performing the assay.

**Prepare reagents:**

**Reconstitute standard:**

Reconstitute contents of one standard vial with Assay Dilution

<b>Prepared By :</b> Ms. Gopika S. L. <b>Designation:</b> Laboratory Technician (P-5410)	<b>Signature:</b> 	<b>Issue Date :</b> 09.07.2021	<b>Page No :</b> 6
<b>Verified By :</b> Dr. Dinoop K. P. <b>Designation:</b> Assistant Professor, Microbiology	<b>Signature:</b> 	<b>Revision No:</b>	<b>Copy no:</b> <b>Controlled</b>
<b>Issued By :</b> Dr. Kavita Raja <b>Designation:</b> Professor & Head, Microbiology	<b>Signature :</b> 	<b>ICMR Extramural Adhoc: P-5410</b>	

**Department of Microbiology**  
**Sree Chitra Tirunal Institute for Medical Sciences and Technology (SCTIMST)**

1. buffer to 5,000 pg/mL. See label on the vial for the reconstitution volume. Mix by inverting the vial  $\times$  times. Do not vortex.

**Note:** Do mix by pipetting because the crystallized powder can be trapped in the pipette tip. If the powder does not go into solution after a few minutes, repeat the inversion.

2. Incubate for 15 minutes at room temperature. **(Figure 2)**

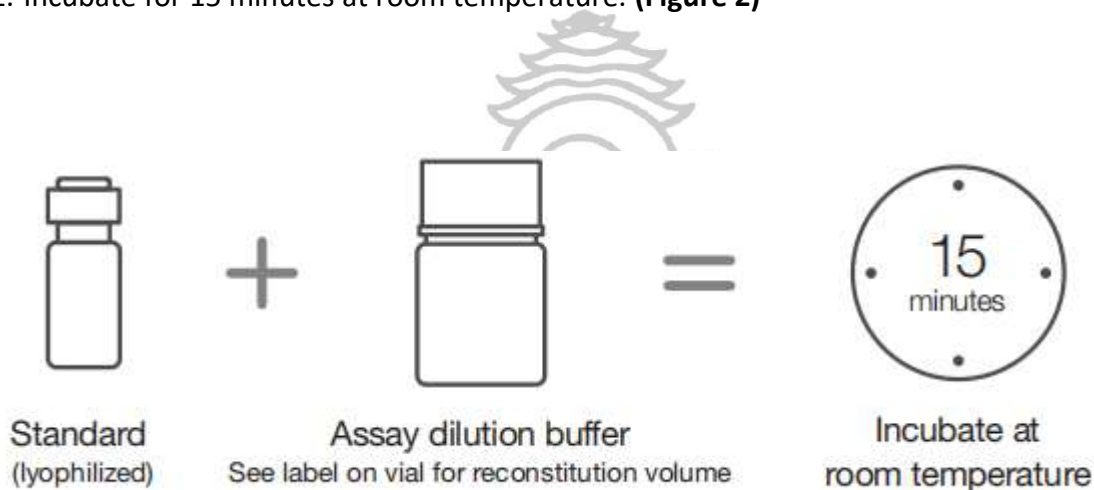

(Figure 2)

**Prepare working plate (on cold block 4°C): (Figure 4)**

**Mix antibody-conjugates**

The volumes provided in the following table are sufficient to run an entire 96-well plate using a 50  $\mu$ L reaction volume. The volumes can be scaled proportionally depending upon the number of assay wells being used and the reaction volume. If using 20  $\mu$ L reaction volumes, 2  $\mu$ L of antibody-conjugate mixture is required for each assay well. If using 50  $\mu$ L reaction volumes, 5  $\mu$ L of antibody-conjugate mixture is required for each assay well.

1. Add the following components to a 1.5-mL microcentrifuge tube, then mix by pipetting up and down.

Component	Volume
Antibody-conjugate A	12 $\mu$ L

<b>Prepared By :</b> Ms. Gopika S. L. <b>Designation:</b> Laboratory Technician (P-5410)	<b>Signature:</b> 	<b>Issue Date :</b> 09.07.2021	<b>Page No : 7</b>
<b>Verified By :</b> Dr. Dinoop K. P. <b>Designation:</b> Assistant Professor, Microbiology	<b>Signature:</b> 	<b>Revision No:</b>	<b>Copy no:</b> <b>Controlled</b>
<b>Issued By :</b> Dr. Kavita Raja <b>Designation:</b> Professor & Head, Microbiology	<b>Signature :</b> 	<b>ICMR Extramural Adhoc: P-5410</b>	

**Department of Microbiology**  
**Sree Chitra Tirunal Institute for Medical Sciences and Technology (SCTIMST)**

Antibody-conjugate B	12 $\mu$ L
Antibody-conjugate Dilution Buffer	696 $\mu$ L

2. Dispense  $\geq 80$   $\mu$ L of antibody-conjugate mixture to each well in one column of the working plate.

**Note:** This step may not be needed if only running partial plates or not using a multi-channel pipette.

**Dilute samples 10-fold:**

Sample dilution is performed directly in the working plate.

1. Add the volumes of sample and Assay Dilution buffer in each assay well of the working plate.

Component	20 $\mu$ L reaction	50 $\mu$ L reaction
Assay Dilution Buffer	18 $\mu$ L	45 $\mu$ L
Unknown sample	2 $\mu$ L	5 $\mu$ L



2. Mix by pipetting up and down.

**Create standard curve:**

1. Add 80  $\mu$ L of Assay Dilution buffer to each well (S1–S7) in one column of the working plate that is reserved for standards.

2. Mix reconstituted standard by gently inverting the vial eye times. Transfer 20  $\mu$ L of Hu IL-1 $\beta$  Protein Standard to the first well (S1), then mix.

3. Make serial dilutions of the standard by transferring 20  $\mu$ L from well S1 to well S2. Continue serial dilution to well S7. The Background well (B) should only contain Assay Dilution buffer. Mix wells thoroughly. Change pipetting tips between dilution steps (Figure 3)

<b>Prepared By :</b> Ms. Gopika S. L. <b>Designation:</b> Laboratory Technician (P-5410)	<b>Signature:</b> 	<b>Issue Date :</b> 09.07.2021	<b>Page No : 8</b>
<b>Verified By :</b> Dr. Dinoop K. P. <b>Designation:</b> Assistant Professor, Microbiology	<b>Signature:</b> 	<b>Revision No:</b>	<b>Copy no: Controlled</b>
<b>Issued By :</b> Dr. Kavita Raja <b>Designation:</b> Professor & Head, Microbiology	<b>Signature :</b> 	<b>ICMR Extramural Adhoc: P-5410</b>	

**Department of Microbiology**  
**Sree Chitra Tirunal Institute for Medical Sciences and Technology (SCTIMST)**

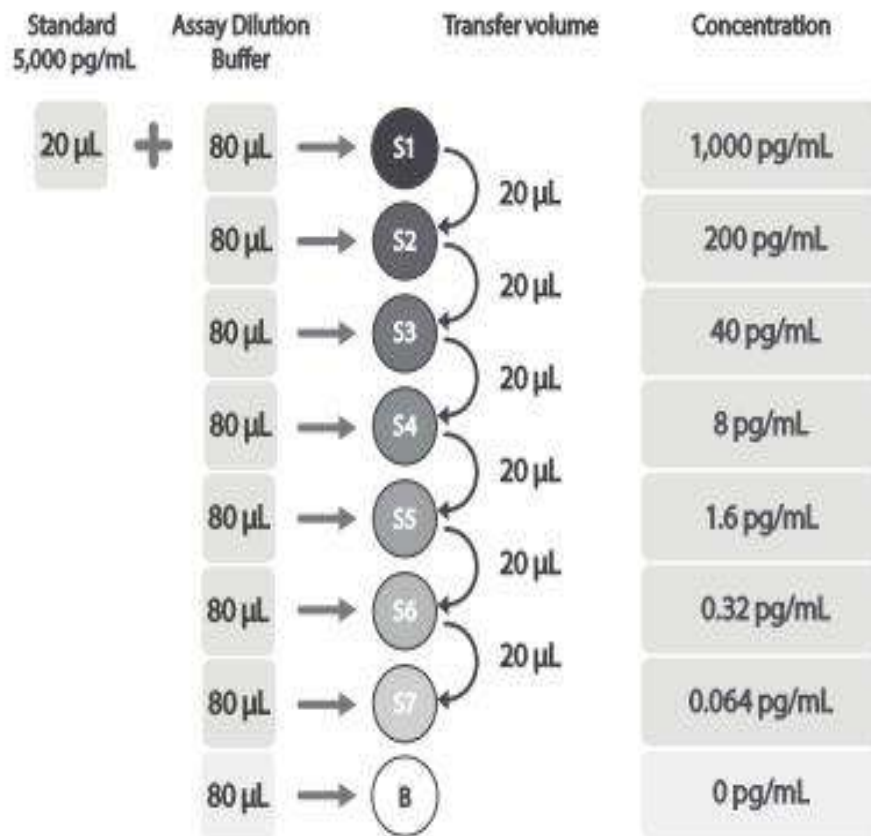

(Figure 3)

4. Seal the working plate with an adhesive seal using the plate seal hand tool.
5. Mix by striking the side of the plate against the palm of your hand three times. Rotate the plate and strike the other side of the plate against your palm three times.
6. Centrifuge at  $3,000 \times g$  for 1 minute to collect the liquid at the bottom of all wells.
7. Discard remaining unused reconstituted standard.

<b>Prepared By :</b> Ms. Gopika S. L. <b>Designation:</b> Laboratory Technician (P-5410)	<b>Signature:</b> 	<b>Issue Date :</b> 09.07.2021	<b>Page No :</b> 9
<b>Verified By :</b> Dr. Dinoop K. P. <b>Designation:</b> Assistant Professor, Microbiology	<b>Signature:</b> 	<b>Revision No:</b>	<b>Copy no:</b> Controlled
<b>Issued By :</b> Dr. Kavita Raja <b>Designation:</b> Professor & Head, Microbiology	<b>Signature :</b> 	<b>ICMR Extramural Adhoc: P-5410</b>	

**Prepare working plate (on cold block 4°C)**

This is a typical example of a working plate to run the ProQuantum Immunoassay on an entire 96-well plate using 5-µL sample volumes, and a general serial dilution diagram for a standard curve.

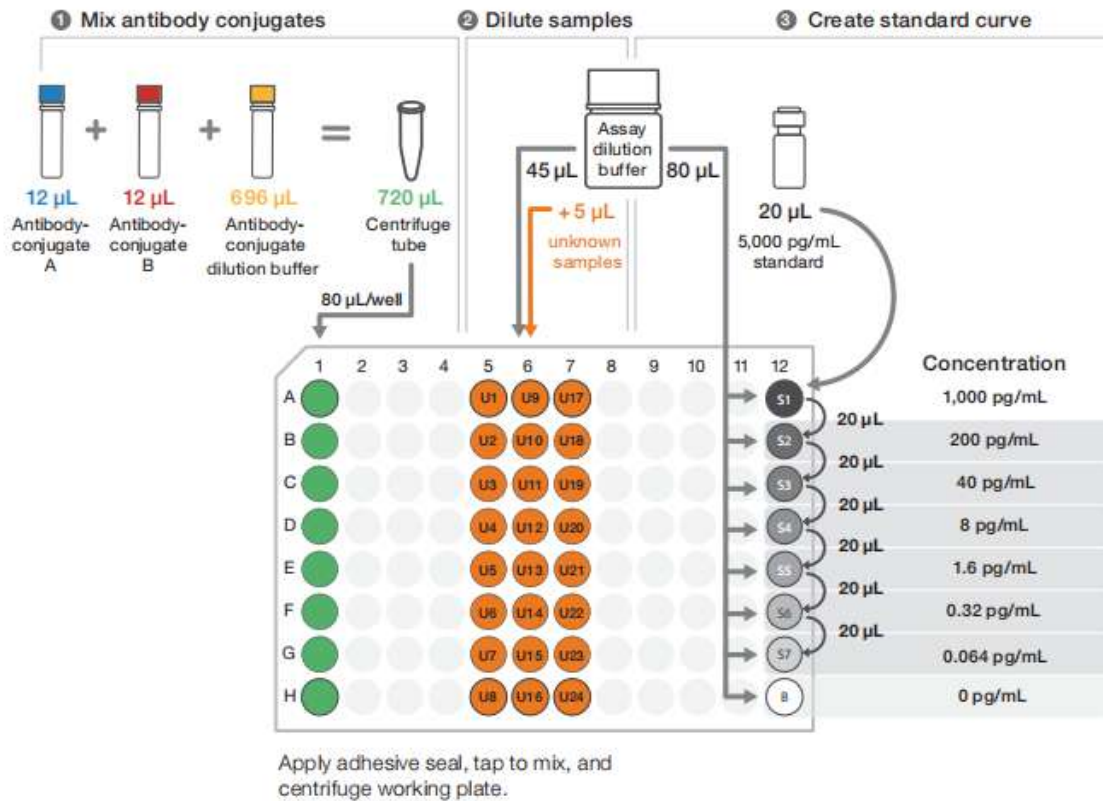

(Figure 4)

**Run assay**

**Bind analyte (1 hour): (Figure 5)**

Keep the assay plate on a plate rack except during mixing or centrifugation steps.

1. Use a multichannel pipette to transfer the volume of antibody-conjugate mixture appropriate for your reaction volume from the working plate to all assay wells in the assay plate.

20 µL reaction	50 µL reaction
2 µL	5 µL

<b>Prepared By :</b> Ms. Gopika S. L. <b>Designation:</b> Laboratory Technician (P-5410)	<b>Signature:</b> 	<b>Issue Date :</b> 09.07.2021	<b>Page No</b> 10
<b>Verified By :</b> Dr. Dinoop K. P. <b>Designation:</b> Assistant Professor, Microbiology	<b>Signature:</b> 	<b>Revision No:</b>	<b>Copy no:</b> Controlled
<b>Issued By :</b> Dr. Kavita Raja <b>Designation:</b> Professor & Head, Microbiology	<b>Signature :</b> 	<b>ICMR Extramural Adhoc: P-5410</b>	

3. Transfer the volume of standards or diluted samples appropriate for your reaction volume from the working plate to the appropriate wells in the assay plate. Mix thoroughly by pipetting up and down several times.

20 $\mu\text{L}$ reaction	50 $\mu\text{L}$ reaction
2 $\mu\text{L}$	5 $\mu\text{L}$

4. Seal the assay plate with an adhesive seal. Mix by striking the plate as previously described. Centrifuge at  $3000 \times g$  for 1 minute. Incubate the assay plate for 1 hour at room temperature. (*Optional*) Incubate the assay plate overnight at  $4^\circ\text{C}$ .

### Bind analyte

Transfer 5  $\mu\text{L}$  of antibody-conjugate mixture to all wells. Then add 5  $\mu\text{L}$  of the standard or the unknown samples to appropriate wells. Mix by pipetting up and down.

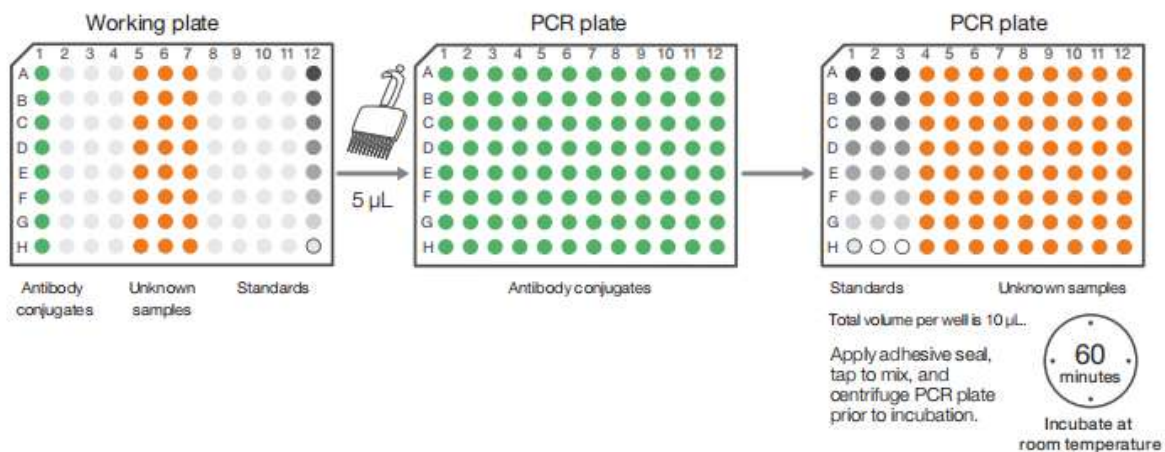

(Figure 5)

### Perform qPCR: (Figure 6)

1. Add 5 mL of Master Mix and 30  $\mu\text{L}$  of Ligase to a 15-mL conical tube. Invert the tube five times, then pour the qPCR reaction mixture into a reagent reservoir.

**Note:** These volumes are sufficient to run an entire 96-well plate using a 50  $\mu\text{L}$  reaction volume. The volumes can be scaled proportionally depending upon the number of assay wells being used and the reaction volume.

<b>Prepared By :</b> Ms. Gopika S. L. <b>Designation:</b> Laboratory Technician (P-5410)	<b>Signature:</b> 	<b>Issue Date :</b> 09.07.2021	<b>Page No</b> 11
<b>Verified By :</b> Dr. Dinoop K. P. <b>Designation:</b> Assistant Professor, Microbiology	<b>Signature:</b> 	<b>Revision No:</b>	<b>Copy no:</b> <b>Controlled</b>
<b>Issued By :</b> Dr. Kavita Raja <b>Designation:</b> Professor & Head, Microbiology	<b>Signature :</b> 	<b>ICMR Extramural Adhoc: P-5410</b>	

**Department of Microbiology**  
**Sree Chitra Tirunal Institute for Medical Sciences and Technology (SCTIMST)**

2. Add the volume of qPCR reaction mixture appropriate for your reaction volume to all assay wells. Mix by pipetting up and down. Avoid introducing bubbles in the wells.

20 $\mu$ L reaction	50 $\mu$ L reaction
16 $\mu$ L	40 $\mu$ L

3. Seal the assay plate with an optical plate seal. Ensure there is complete adhesion using the plate seal hand tool.

4. Mix by striking the plate as previously described, then centrifuge at  $3,000 \times g$  for 1 minute.

### Perform qPCR

Add 40  $\mu$ L of qPCR reaction mixture to all wells. Mix by pipetting up and down.

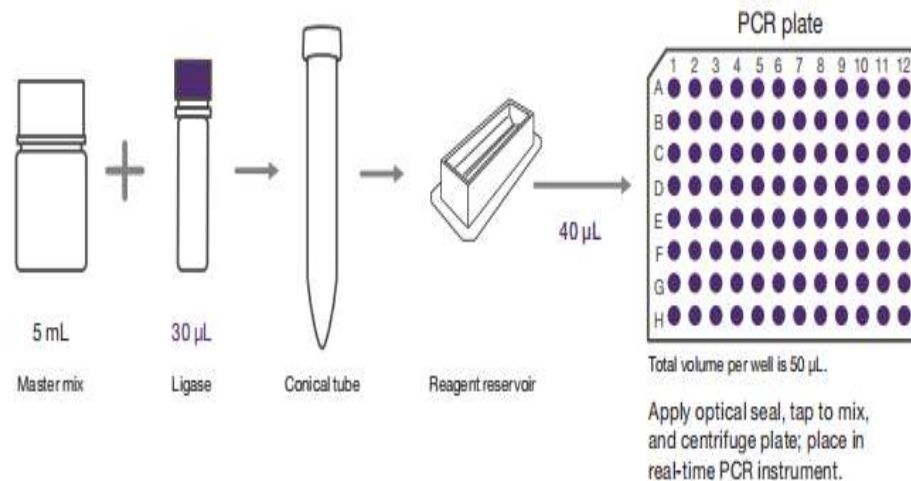

(Figure 6)

<b>Prepared By :</b> Ms. Gopika S. L. <b>Designation:</b> Laboratory Technician (P-5410)	<b>Signature:</b> 	<b>Issue Date :</b> 09.07.2021	<b>Page No</b> 12
<b>Verified By :</b> Dr. Dinoop K. P. <b>Designation:</b> Assistant Professor, Microbiology	<b>Signature:</b> 	<b>Revision No:</b>	<b>Copy no:</b> Controlled
<b>Issued By :</b> Dr. Kavita Raja <b>Designation:</b> Professor & Head, Microbiology	<b>Signature :</b> 	<b>ICMR Extramural Adhoc: P-5410</b>	

**Department of Microbiology**  
**Sree Chitra Tirunal Institute for Medical Sciences and Technology (SCTIMST)**

5. Create a new Experiment on the qPCR instrument.

Parameter	Settings for Applied Biosystems instruments
Experiment type	Standard Curve or Quantitation - Standard Curve
Reagents	TaqMan reagents
Reporter dye	FAM
Quencher	NFQ-MGB [1]
Passive reference	ROX
Assign wells	Define all wells of the 96-well plate as Unknown
Threshold	0.2
Baseline	3–15



For instruments without this option, enter "None" or "Non-fluorescent".

6. Input the PCR Method based on your instrument block type.

Step	Temp (°C)	Time (by block type)		Stage
		Standard	Fast	
Ligation	25	20 min	20 min	Hold
Ligase inactivation	95	2 min	2 min	Hold
Denaturation	95	15 s	1 s	40 Cycles
Annealing/extension	95	1 min	20 s	

[1] Set ramp rate to 2°C/sec

[2] Use default values for 7500, 7500 Fast, 7900HT, or non-Applied Bio-systems instruments (e.g., 3 s denaturation and 30 s annealing/extension).

<b>Prepared By :</b> Ms. Gopika S. L. <b>Designation:</b> Laboratory Technician (P-5410)	<b>Signature:</b> 	<b>Issue Date :</b> 09.07.2021	<b>Page No 13</b>
<b>Verified By :</b> Dr. Dinoop K. P. <b>Designation:</b> Assistant Professor, Microbiology	<b>Signature:</b> 	<b>Revision No:</b>	<b>Copy no: Controlled</b>
<b>Issued By :</b> Dr. Kavita Raja <b>Designation:</b> Professor & Head, Microbiology	<b>Signature :</b> 	<b>ICMR Extramural Adhoc: P-5410</b>	

### Instrument run conditions

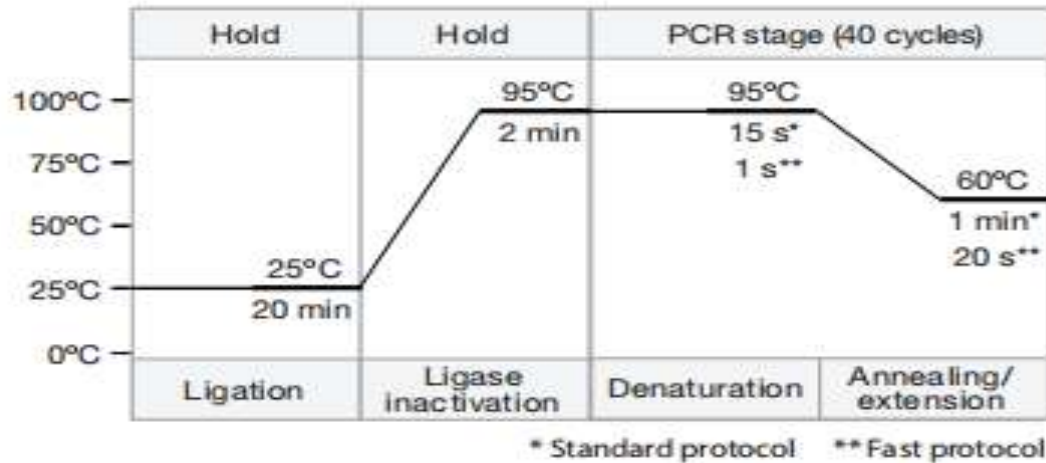

(Figure 7)

7. Save the Experiment as a template. Run the template.

**Note:** Reuse the saved template for subsequent assays using the same block type.

#### 5.5.3d. Type of sample:

Serum	2-5 $\mu$ L
Plasma	2-5 $\mu$ L
Supernatant (Body fluids)	2-5 $\mu$ L

5.5.3e. Patient preparation: As per sample collection manual

#### 5.5.3f. Type of container and additives:

Serum:	Red-Top Tube (without additive)
CSF:	Sterile container (without additive)

#### 5.5.3g. Required equipment and reagents:

##### Equipment's:

1. Calibrated pipettes and low retention filter tips
2. 96-well plate cold block
3. 96-well assay plate and 96-well working plate

<b>Prepared By :</b> Ms. Gopika S. L. <b>Designation:</b> Laboratory Technician (P-5410)	<b>Signature:</b> 	<b>Issue Date :</b> 09.07.2021	<b>Page No</b> 14
<b>Verified By :</b> Dr. Dinoop K. P. <b>Designation:</b> Assistant Professor, Microbiology	<b>Signature:</b> 	<b>Revision No:</b>	<b>Copy no:</b> Controlled
<b>Issued By :</b> Dr. Kavita Raja <b>Designation:</b> Professor & Head, Microbiology	<b>Signature :</b> 	<b>ICMR Extramural Adhoc: P-5410</b>	

**Department of Microbiology**  
**Sree Chitra Tirunal Institute for Medical Sciences and Technology (SCTIMST)**

4. 25-mL reagent reservoir × 2
5. Microtiter plate adhesive seals × 2
6. Microtiter plate adhesive seal, optical grade
7. Plate seal hand tool
8. Centrifuge with swinging bucket rotor for 96-well
9. plates, and microcentrifuge
10. 96-well plate rack
11. RNase-free 1.5-mL microcentrifuge tube
12. Sterile 15-mL conical tube

**Reagents: (Figure 8)**

Contents :

- Assay Dilution Buffer
- Antibody-Conjugate A
- Antibody-Conjugate B
- Antibody-Conjugate Dilution Buffer
- Standard (IL-1 beta)
- Master Mix
- Ligase

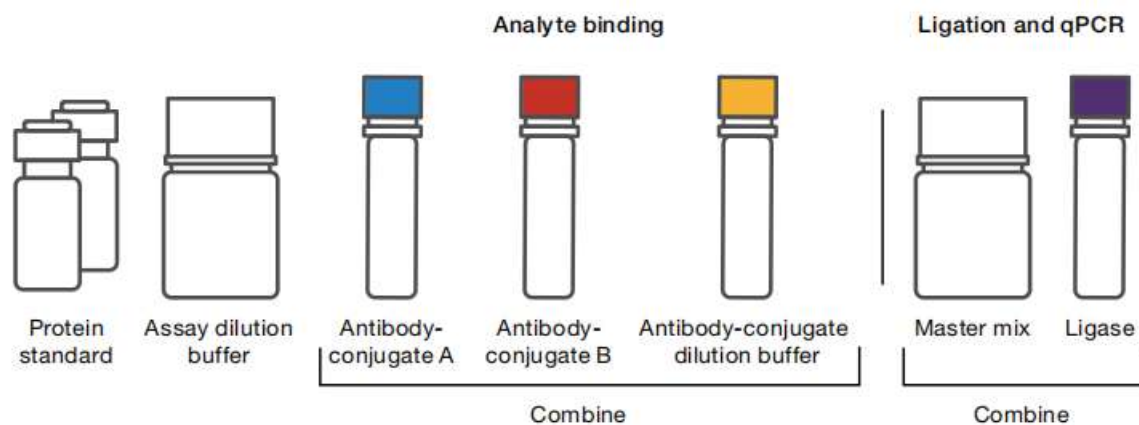

**(Figure 8)**

<b>Prepared By :</b> Ms. Gopika S. L. <b>Designation:</b> Laboratory Technician (P-5410)	<b>Signature:</b> 	<b>Issue Date :</b> 09.07.2021	<b>Page No</b> 15
<b>Verified By :</b> Dr. Dinoop K. P. <b>Designation:</b> Assistant Professor, Microbiology	<b>Signature:</b> 	<b>Revision No:</b>	<b>Copy no:</b> Controlled
<b>Issued By :</b> Dr. Kavita Raja <b>Designation:</b> Professor & Head, Microbiology	<b>Signature :</b> 	<b>ICMR Extramural Adhoc: P-5410</b>	

**Department of Microbiology**  
**Sree Chitra Tirunal Institute for Medical Sciences and Technology (SCTIMST)**

**5.5.3h. Environmental and safety controls:**

1. Wear gloves, use DNase/RNase/pyrogen free plastic ware, and practice proper DNA handling techniques.
2. Wear goggles, Lab coat, and put-up hair
3. Use UV-C germicidal lamp in the hood to sterilize the interior and contents before usage to prevent contamination of the experiment for 15 minutes before the hood is used.
4. Sterile the hood with Eco-shield prior and preposition of procedure.



**5.5.3i. Calibration procedures:** As per kit and instrument manufacturer instructions

**5.5.3j. Steps of the procedure:** Same as 5.5.3c

**5.5.3k. Quality control procedures:** As per kit and instrument manufacturer instructions

**5.5.3l. Interference:**

1. The ProQuantum immunoassay is a DNA assay and will not perform properly if samples contain inhibitors that affect such assays (e.g., DNA ligase inhibitors).
2. Use a plate seal hand tool to ensure complete adherence to avoid any evaporation or contamination.
3. Use best practices with pipetting to minimize CV.
4. Use a working plate to prepare reagents and a multi-channel pipette when transferring reagents to the assay plate to minimize handling time and thus, evaporation.
5. Use a plate rack to hold the assay plate to avoid splashing when unsealing the adhesive seals.
6. Outliers are more readily identified if the assay is run in triplicate.
7. Be sure to use appropriate PCR plates that are compatible with the qPCR instrument and block type.
8. Do not vortex plates.

<b>Prepared By :</b> Ms. Gopika S. L. <b>Designation:</b> Laboratory Technician (P-5410)	<b>Signature:</b> 	<b>Issue Date :</b> 09.07.2021	<b>Page No 16</b>
<b>Verified By :</b> Dr. Dinoop K. P. <b>Designation:</b> Assistant Professor, Microbiology	<b>Signature:</b> 	<b>Revision No:</b>	<b>Copy no: Controlled</b>
<b>Issued By :</b> Dr. Kavita Raja <b>Designation:</b> Professor & Head, Microbiology	<b>Signature :</b> 	<b>ICMR Extramural Adhoc: P-5410</b>	

9. Mixing of the reagents is critical to the assay. Mixing can be performed by careful Pipetting up and down 10 times, or by striking the side of the plate against the palm of your hand or a stationary object like the lab bench. The strike should be hard enough to cause liquid to splash to the top of the adhesive seals and to the other side within the well.

**5.5.3m. Principle and procedure for calculation of results:**

The amount of DNA produced is measured after each amplification cycle via fluorescent dyes, which exhibit fluorescence that is directly proportional to the number of PCR product molecules (or amplicons) generated. This graph shows the fluorescence vs. cycle number curves for four different starting protein concentrations. The dashed line represents the fluorescence threshold. The cycle number required to reach the fluorescence threshold (threshold cycle or Ct) is plotted vs. protein concentration to create a standard curve. (Figure 9)

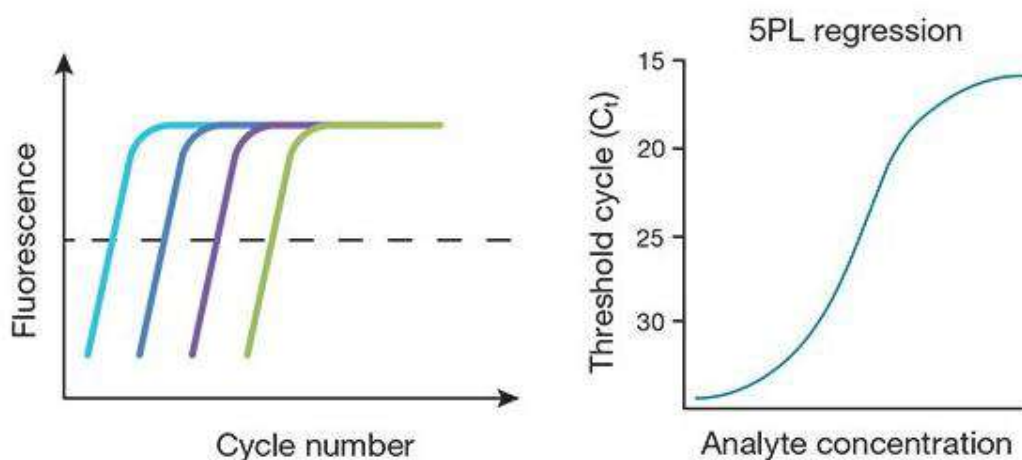

(Figure 9)

**5.5.3n. Biological reference intervals:** 0.064 – 10000 pg/mL

**5.5.3o Reportable interval of examination results:** 2 hr

<b>Prepared By :</b> Ms. Gopika S. L. <b>Designation:</b> Laboratory Technician (P-5410)	<b>Signature:</b> 	<b>Issue Date :</b> 09.07.2021	<b>Page No</b> 17
<b>Verified By :</b> Dr. Dinoop K. P. <b>Designation:</b> Assistant Professor, Microbiology	<b>Signature:</b> 	<b>Revision No:</b>	<b>Copy no:</b> Controlled
<b>Issued By :</b> Dr. Kavita Raja <b>Designation:</b> Professor & Head, Microbiology	<b>Signature :</b> 	<b>ICMR Extramural Adhoc: P-5410</b>	

**Department of Microbiology**  
**Sree Chitra Tirunal Institute for Medical Sciences and Technology (SCTIMST)**

**5.5.3p. Instructions to determine quantitative results** (if not within measurement interval):

Serial doubling dilutions

**5.5.3q. Critical values/alerts:** >100 pg/ml



**5.5.3r. Laboratory clinical interpretation:**

**Raised CSF IL-1beta:** Indicative of Gram-negative bacterial infection <sup>[4]</sup>

**5.5.3s. Potential sources of variation:** Nil

**5.5.3t. References:**

1. Product Sheet: ProQuantum Human IL-1beta Immunoassay Kit
2. Quick Reference: ProQuantum Human IL-1beta Immunoassay Kit
3. User Guide: ProQuantum Human IL-1beta Immunoassay Kit
1. Abudeev SA, Kiselev KV, Kruglyakov NM, Belousova KA, Lobanova IN, Parinov OV, et al. Cerebrospinal Fluid Presepsin As a Marker of Nosocomial Infections of the Central Nervous System: A Prospective Observational Study. Front Neurol 2018;9:58.

<b>Prepared By :</b> Ms. Gopika S. L. <b>Designation:</b> Laboratory Technician (P-5410)	<b>Signature:</b> 	<b>Issue Date :</b> 09.07.2021	<b>Page No 18</b>
<b>Verified By :</b> Dr. Dinoop K. P. <b>Designation:</b> Assistant Professor, Microbiology	<b>Signature:</b> 	<b>Revision No:</b>	<b>Copy no:</b> <b>Controlled</b>
<b>Issued By :</b> Dr. Kavita Raja <b>Designation:</b> Professor & Head, Microbiology	<b>Signature :</b> 	<b>ICMR Extramural Adhoc: P-5410</b>	

## **2. Human IL-17A Immunoassay**

### **5.5.3a. Purpose of the examination:**

To provide highly sensitive quantitative measurements of Human IL-17A protein in small sample volumes.



### **5.5.3b. Principle and method of examination:**

Utilizing **proximity ligation assay (PLA) technology**, the assay combines the analyte specificity of high-affinity antibody-antigen binding with the signal detection and amplification capabilities of real-time PCR to achieve a simple yet powerful next-generation protein quantitation platform.

**(A) Antibody-antigen binding:** Antibodies bind to two separate epitopes on the antigen (during a 1-hr incubation), which brings the two conjugated oligonucleotides into close proximity.

**(B) Ligation and amplification of signal (in a qPCR instrument):** DNA ligase and a third splint oligonucleotide connector are added to ligate the two ends of the conjugated oligonucleotides, creating a 100-base DNA template. Once the ligase is inactivated at 95°C, the sample is amplified through 40 cycles of annealing and extension. The amount of DNA produced is measured after each amplification cycle via fluorescent dyes, which exhibit fluorescence that is directly proportional to the number of PCR product molecules (or amplicons) generated. This graph shows the fluorescence vs. cycle number curves for four different starting protein concentrations. The dashed line represents the fluorescence threshold. The cycle number required to reach the fluorescence threshold (threshold cycle or Ct) is plotted vs. protein concentration to create a standard curve.

Assay runs on any real-time PCR instrument. ProQuantum immuno assays utilize a matched pair of target-specific antibodies, each conjugated to a DNA oligonucleotide. During antibody-analyte binding, the two DNA oligos are brought into close proximity, which allows for ligation of the two strands and subsequent creation of a template strand for amplification. This

<b>Prepared By :</b> Ms. Gopika S. L. <b>Designation:</b> Laboratory Technician (P-5410)	<b>Signature:</b> 	<b>Issue Date :</b> 09.07.2021	<b>Page No</b> 19
<b>Verified By :</b> Dr. Dinoop K. P. <b>Designation:</b> Assistant Professor, Microbiology	<b>Signature:</b> 	<b>Revision No:</b>	<b>Copy no:</b> <b>Controlled</b>
<b>Issued By :</b> Dr. Kavita Raja <b>Designation:</b> Professor & Head, Microbiology	<b>Signature :</b> 	<b>ICMR Extramural Adhoc: P-5410</b>	

**Department of Microbiology**  
**Sree Chitra Tirunal Institute for Medical Sciences and Technology (SCTIMST)**

platform leverages the sensitivity and large dynamic range of Applied Biosystems TaqMan real-time PCR technology (Figure1).

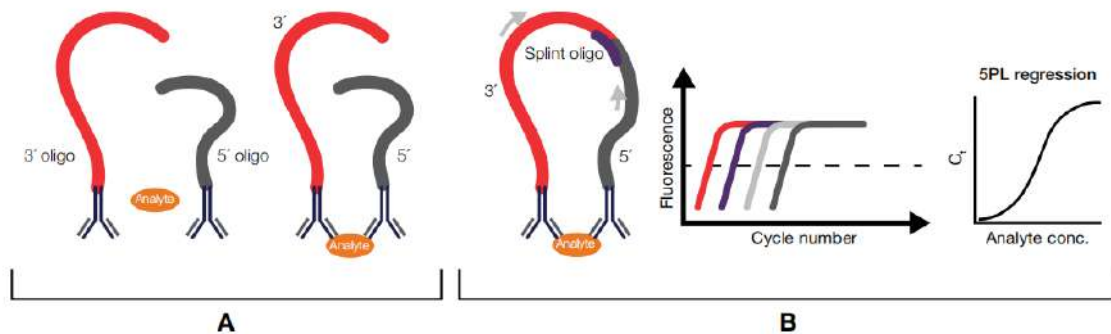

(Figure 1)

**5.5.3c. Procedure of the examination: ProQuantum Human IL-1 17A immunoassay**

**Guidelines for handling reagents:**

1. Centrifuge vials before pipetting to ensure the contents are at the bottom of the tube.
2. Do not thaw Ligase. Always keep Ligase at  $-20^{\circ}\text{C}$  or on ice. Ligase is viscous. Careful with pipetting accurate amounts and not cause bubbles.
3. Thaw all reagents except Ligase at room temperature.
4. Larger vials like Assay Dilution buffer may take a while to thaw and can be thawed in a warm water bath.
5. Keep Ligase and thawed reagents on ice.
6. Use a refrigerated cold block for the working plate to keep all reagents cool during preparation steps. If a cold block is not available, keep the working plate on ice.
7. If any particulate matter is present in the sample, centrifuge or filter sample before performing the assay.

**Prepare reagents:**

**Reconstitute standard:**

Reconstitute contents of one standard vial with Assay Dilution

<b>Prepared By :</b> Ms. Gopika S. L. <b>Designation:</b> Laboratory Technician (P-5410)	<b>Signature:</b> 	<b>Issue Date :</b> 09.07.2021	<b>Page No</b> 20
<b>Verified By :</b> Dr. Dinoop K. P. <b>Designation:</b> Assistant Professor, Microbiology	<b>Signature:</b> 	<b>Revision No:</b>	<b>Copy no:</b> Controlled
<b>Issued By :</b> Dr. Kavita Raja <b>Designation:</b> Professor & Head, Microbiology	<b>Signature :</b> 	<b>ICMR Extramural Adhoc: P-5410</b>	

**Department of Microbiology**  
**Sree Chitra Tirunal Institute for Medical Sciences and Technology (SCTIMST)**

1. buffer to 5,000 pg/mL. See label on the vial for the reconstitution volume. Mix by inverting the vial 5 times. Do not vortex.

**Note:** Do mix by pipetting because the crystallized powder can be trapped in the pipette tip. If the powder does not go into solution after a few minutes, repeat the inversion.

2. Incubate for 15 minutes at room temperature. (Figure 2)

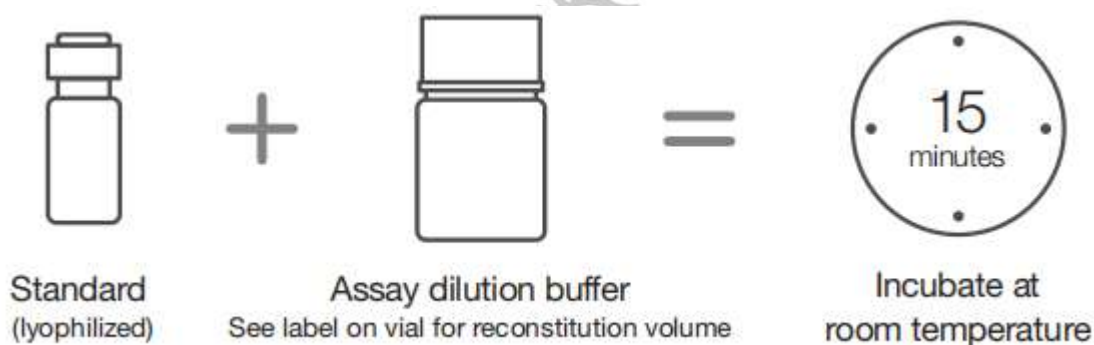

(Figure 2)

Prepare working plate (on cold block 4°C): (Figure 4)

**Mix antibody-conjugates**

The volumes provided in the following table are sufficient to run an entire 96-well plate using a 50 µL reaction volume. The volumes can be scaled proportionally depending upon the number of assay wells being used and the reaction volume. If using 20 µL reaction volumes, 2 µL of antibody-conjugate mixture is required for each assay well. If using 50 µL reaction volumes, 5 µL of antibody-conjugate mixture is required for each assay well.

1. Add the following components to a 1.5-mL microcentrifuge tube, then mix by pipetting up and down.

Component	Volume
Antibody-conjugate A	12 µL
Antibody-conjugate B	12 µL
Antibody-conjugate Dilution Buffer	696 µL

<b>Prepared By :</b> Ms. Gopika S. L. <b>Designation:</b> Laboratory Technician (P-5410)	<b>Signature:</b> 	<b>Issue Date :</b> 09.07.2021	<b>Page No</b> 21
<b>Verified By :</b> Dr. Dinoop K. P. <b>Designation:</b> Assistant Professor, Microbiology	<b>Signature:</b> 	<b>Revision No:</b>	<b>Copy no:</b> Controlled
<b>Issued By :</b> Dr. Kavita Raja <b>Designation:</b> Professor & Head, Microbiology	<b>Signature :</b> 	<b>ICMR Extramural Adhoc: P-5410</b>	

**Department of Microbiology**  
**Sree Chitra Tirunal Institute for Medical Sciences and Technology (SCTIMST)**

2. Dispense  $\geq 80 \mu\text{L}$  of antibody-conjugate mixture to each well in one column of the working plate.

**Note:** This step may not be needed if only running partial plates or not using a multi-channel pipette.

**Dilute samples 10-fold :**

Sample dilution is performed directly in the working plate.

1. Add the volumes of sample and Assay Dilution buffer in each assay well of the working plate.

Component	20 $\mu\text{L}$ reaction	50 $\mu\text{L}$ reaction
Assay Dilution Buffer	18 $\mu\text{L}$	45 $\mu\text{L}$
Unknown sample	2 $\mu\text{L}$	5 $\mu\text{L}$



2. Mix by pipetting up and down.

**Create standard curve:**

1. Add 80  $\mu\text{L}$  of Assay Dilution buffer to each well (S1–S7) in one column of the working plate that is reserved for standards.

2. Mix reconstituted standard by gently inverting the vial 5 times. Transfer 20  $\mu\text{L}$  of Hu IL-1 $\beta$  Protein Standard to the first well (S1), then mix.

3. Make serial dilutions of the standard by transferring 20  $\mu\text{L}$  from well S1 to well S2. Continue serial dilution to well S7. The Background well (B) should only contain Assay Dilution buffer. Mix wells thoroughly. Change pipetting tips between dilution steps (Figure 3)

<b>Prepared By :</b> Ms. Gopika S. L. <b>Designation:</b> Laboratory Technician (P-5410)	<b>Signature:</b> 	<b>Issue Date :</b> 09.07.2021	<b>Page No</b> 22
<b>Verified By :</b> Dr. Dinoop K. P. <b>Designation:</b> Assistant Professor, Microbiology	<b>Signature:</b> 	<b>Revision No:</b>	<b>Copy no:</b> Controlled
<b>Issued By :</b> Dr. Kavita Raja <b>Designation:</b> Professor & Head, Microbiology	<b>Signature :</b> 	<b>ICMR Extramural Adhoc: P-5410</b>	

**Department of Microbiology**  
**Sree Chitra Tirunal Institute for Medical Sciences and Technology (SCTIMST)**

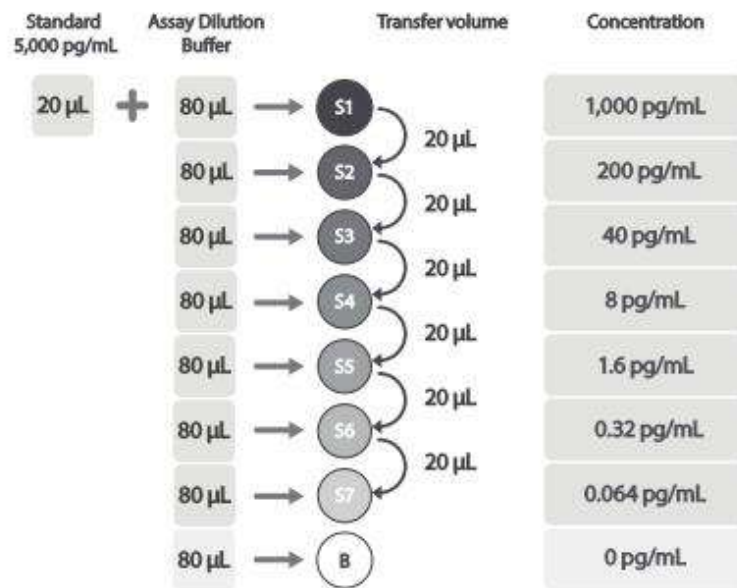

(Figure 3)

4. Seal the working plate with an adhesive seal using the plate seal hand tool.
5. Mix by striking the side of the plate against the palm of your hand three times. Rotate the plate and strike the other side of the plate against your palm three times.
6. Centrifuge at  $3,000 \times g$  for 1 minute to collect the liquid at the bottom of all wells.
7. Discard remaining unused reconstituted standard.

<b>Prepared By :</b> Ms. Gopika S. L. <b>Designation:</b> Laboratory Technician (P-5410)	<b>Signature:</b> 	<b>Issue Date :</b> 09.07.2021	<b>Page No</b> 23
<b>Verified By :</b> Dr. Dinoop K. P. <b>Designation:</b> Assistant Professor, Microbiology	<b>Signature:</b> 	<b>Revision No:</b>	<b>Copy no:</b> Controlled
<b>Issued By :</b> Dr. Kavita Raja <b>Designation:</b> Professor & Head, Microbiology	<b>Signature :</b> 	<b>ICMR Extramural Adhoc: P-5410</b>	

**Prepare working plate (on cold block 4°C)**

This is a typical example of a working plate to run the ProQuantum Immunoassay on an entire 96-well plate using 5-µL sample volumes, and a general serial dilution diagram for a standard curve.

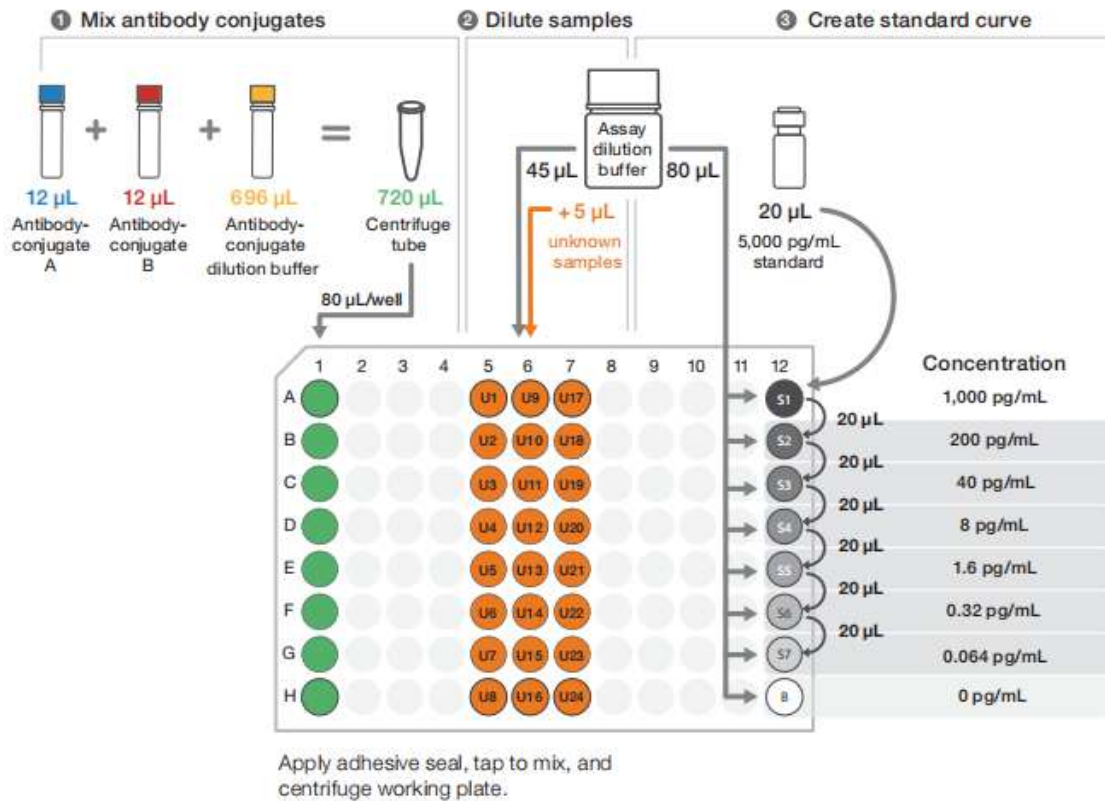

(Figure 4)

**Run assay**

**Bind analyte (1 hour): (Figure 5)**

Keep the assay plate on a plate rack except during mixing or centrifugation steps.

1. Use a multichannel pipette to transfer the volume of antibody-conjugate mixture appropriate for your reaction volume from the working plate to all assay wells in the assay plate.

20 µL reaction	50 µL reaction
2 µL	5 µL

<b>Prepared By :</b> Ms. Gopika S. L. <b>Designation:</b> Laboratory Technician (P-5410)	<b>Signature:</b> 	<b>Issue Date :</b> 09.07.2021	<b>Page No</b> 24
<b>Verified By :</b> Dr. Dinoop K. P. <b>Designation:</b> Assistant Professor, Microbiology	<b>Signature:</b> 	<b>Revision No:</b>	<b>Copy no:</b> Controlled
<b>Issued By :</b> Dr. Kavita Raja <b>Designation:</b> Professor & Head, Microbiology	<b>Signature :</b> 	<b>ICMR Extramural Adhoc: P-5410</b>	

3. Transfer the volume of standards or diluted samples appropriate for your reaction volume from the working plate to the appropriate wells in the assay plate. Mix thoroughly by pipetting up and down several times.

20 $\mu$ L reaction	50 $\mu$ L reaction
2 $\mu$ L	5 $\mu$ L

4. Seal the assay plate with an adhesive seal. Mix by striking the plate as previously described. Centrifuge at  $3000 \times g$  for 1 minute. Incubate the assay plate for 1 hour at room temperature. (*Optional*) Incubate the assay plate overnight at  $4^{\circ}\text{C}$ .

### Bind analyte

Transfer 5  $\mu$ L of antibody-conjugate mixture to all wells. Then add 5  $\mu$ L of the standard or the unknown samples to appropriate wells. Mix by pipetting up and down.

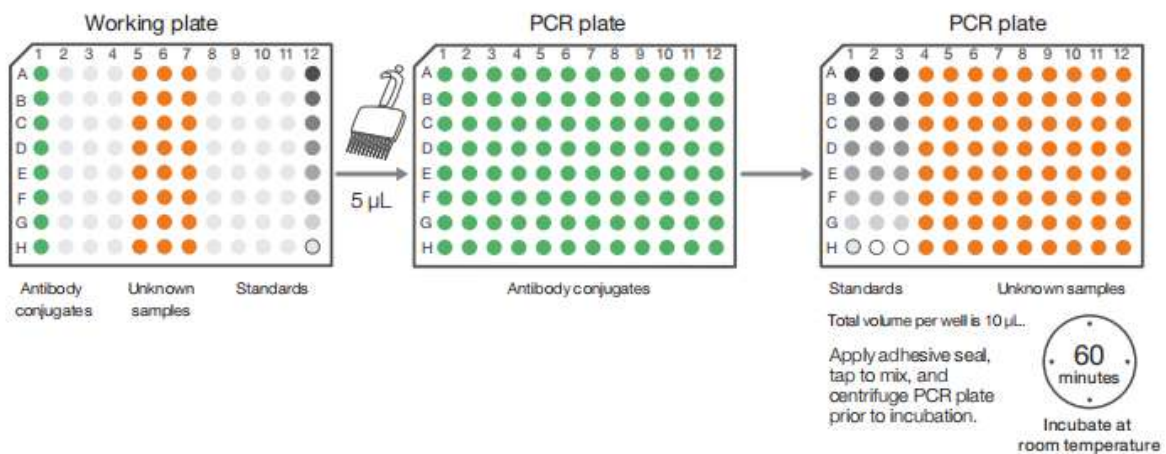

(Figure 5)

### Perform qPCR: (Figure 6)

**1.** Add 5 mL of Master Mix and 30  $\mu$ L of Ligase to a 15-mL conical tube. Invert the tube five times, then pour the qPCR reaction mixture into a reagent reservoir.

<b>Prepared By :</b> Ms. Gopika S. L. <b>Designation:</b> Laboratory Technician (P-5410)	<b>Signature:</b> 	<b>Issue Date :</b> 09.07.2021	<b>Page No</b> 25
<b>Verified By :</b> Dr. Dinoop K. P. <b>Designation:</b> Assistant Professor, Microbiology	<b>Signature:</b> 	<b>Revision No:</b>	<b>Copy no:</b> Controlled
<b>Issued By :</b> Dr. Kavita Raja <b>Designation:</b> Professor & Head, Microbiology	<b>Signature :</b> 	<b>ICMR Extramural Adhoc: P-5410</b>	

**Department of Microbiology**  
**Sree Chitra Tirunal Institute for Medical Sciences and Technology (SCTIMST)**

**Note:** These volumes are sufficient to run an entire 96-well plate using a 50  $\mu\text{L}$  reaction volume. The volumes can be scaled proportionally depending upon the number of assay wells being used and the reaction volume.

**2.** Add the volume of qPCR reaction mixture appropriate for your reaction volume to all assay wells. Mix by pipetting up and down. Avoid introducing bubbles in the wells.

20 $\mu\text{L}$ reaction	50 $\mu\text{L}$ reaction
16 $\mu\text{L}$	40 $\mu\text{L}$

**3.** Seal the assay plate with an optical plate seal. Ensure there is complete adhesion using the plate seal hand tool.

**4.** Mix by striking the plate as previously described, then centrifuge at  $3,000 \times g$  for 1 minute.

**Perform qPCR**

Add 40  $\mu\text{L}$  of qPCR reaction mixture to all wells. Mix by pipetting up and down.

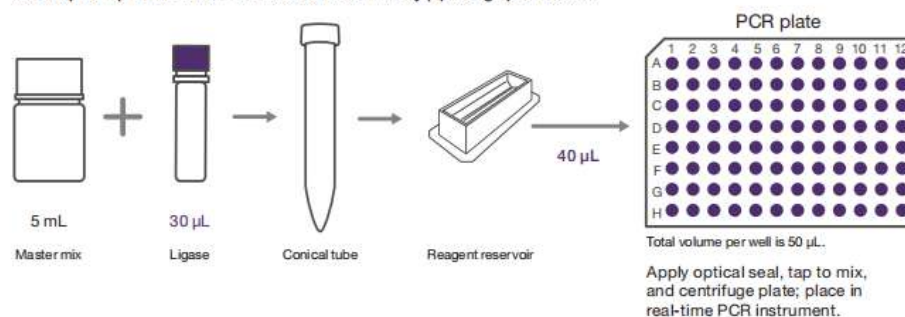

(Figure 6)

<b>Prepared By :</b> Ms. Gopika S. L. <b>Designation:</b> Laboratory Technician (P-5410)	<b>Signature:</b> 	<b>Issue Date :</b> 09.07.2021	<b>Page No</b> 26
<b>Verified By :</b> Dr. Dinoop K. P. <b>Designation:</b> Assistant Professor, Microbiology	<b>Signature:</b> 	<b>Revision No:</b>	<b>Copy no:</b> Controlled
<b>Issued By :</b> Dr. Kavita Raja <b>Designation:</b> Professor & Head, Microbiology	<b>Signature :</b> 	<b>ICMR Extramural Adhoc: P-5410</b>	

**Department of Microbiology**  
**Sree Chitra Tirunal Institute for Medical Sciences and Technology (SCTIMST)**

5. Create a new Experiment on the qPCR instrument.

Parameter	Settings for Applied Biosystems instruments
Experiment type	Standard Curve or Quantitation - Standard Curve
Reagents	TaqMan reagents
Reporter dye	FAM
Quencher	NFQ-MGB [1]
Passive reference	ROX
Assign wells	Define all wells of the 96-well plate as Unknown
Threshold	0.2
Baseline	3–15



For instruments without this option, enter "None" or "Non-fluorescent".

6. Input the PCR Method based on your instrument block type.

Step	Temp (°C)	Time (by block type)		Stage
		Standard	Fast	
Ligation	25	20 min	20 min	Hold
Ligase inactivation	95	2 min	2 min	Hold
Denaturation	95	15 s	1 s	40 Cycles
Annealing/ extension	95	1 min	20 s	

[1] Set ramp rate to 2°C/sec

[2] Use default values for 7500, 7500 Fast, 7900HT, or non-Applied Bio-systems instruments (e.g., 3 s denaturation and 30 s annealing/extension).

<b>Prepared By :</b> Ms. Gopika S. L. <b>Designation:</b> Laboratory Technician (P-5410)	<b>Signature:</b> 	<b>Issue Date :</b> 09.07.2021	<b>Page No 27</b>
<b>Verified By :</b> Dr. Dinoop K. P. <b>Designation:</b> Assistant Professor, Microbiology	<b>Signature:</b> 	<b>Revision No:</b>	<b>Copy no: Controlled</b>
<b>Issued By :</b> Dr. Kavita Raja <b>Designation:</b> Professor & Head, Microbiology	<b>Signature :</b> 	<b>ICMR Extramural Adhoc: P-5410</b>	

### Instrument run conditions

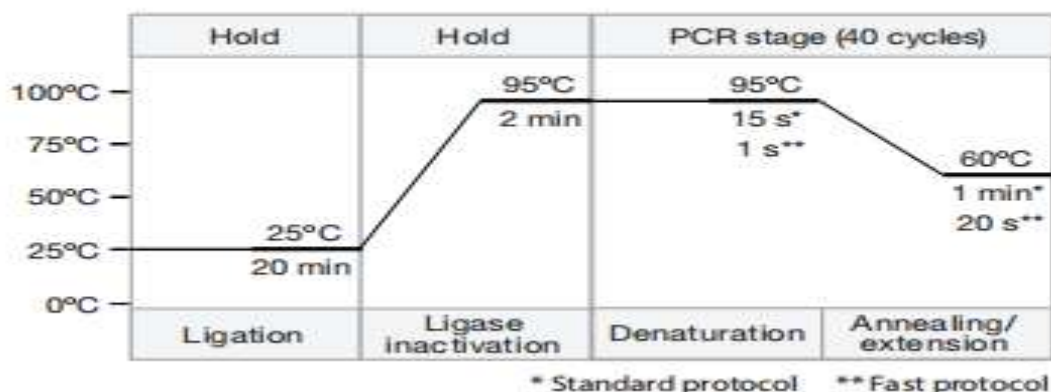

(Figure 7)

7. Save the Experiment as a template. Run the template.

**Note:** Reuse the saved template for subsequent assays using the same block type.

#### 5.5.3d. Type of sample:

Serum	2-5 $\mu$ L
Plasma	2-5 $\mu$ L
Supernatant (Body fluids)	2-5 $\mu$ L

5.5.3e. Patient preparation: As per sample collection manual

#### 5.5.3f. Type of container and additives:

Serum:	Red-Top Tube (without additive)
CSF:	Sterile container (without additive)

#### 5.5.3g. Required equipment and reagents:

##### Equipment's:

1. Calibrated pipettes and low retention filter tips
2. 96-well plate cold block



<b>Prepared By :</b> Ms. Gopika S. L. <b>Designation:</b> Laboratory Technician (P-5410)	<b>Signature:</b> 	<b>Issue Date :</b> 09.07.2021	<b>Page No</b> 28
<b>Verified By :</b> Dr. Dinoop K. P. <b>Designation:</b> Assistant Professor, Microbiology	<b>Signature:</b> 	<b>Revision No:</b>	<b>Copy no:</b> Controlled
<b>Issued By :</b> Dr. Kavita Raja <b>Designation:</b> Professor & Head, Microbiology	<b>Signature :</b> 	<b>ICMR Extramural Adhoc: P-5410</b>	

**Department of Microbiology**  
**Sree Chitra Tirunal Institute for Medical Sciences and Technology (SCTIMST)**

3. 96-well assay plate and 96-well working plate
4. 25-mL reagent reservoir × 2
5. Microtiter plate adhesive seals × 2
6. Microtiter plate adhesive seal, optical grade
7. Plate seal hand tool
8. Centrifuge with swinging bucket rotor for 96-well
9. plates, and microcentrifuge
10. 96-well plate rack
11. RNase-free 1.5-mL microcentrifuge tube
12. Sterile 15-mL conical tube

**Reagents: (Figure 8)**

Assay Dilution Buffer  
Antibody-Conjugate A  
Antibody-Conjugate B  
Antibody-Conjugate Dilution Buffer  
Standard (IL-17A)  
Master Mix  
Ligase

<b>Prepared By :</b> Ms. Gopika S. L. <b>Designation:</b> Laboratory Technician (P-5410)	<b>Signature:</b> 	<b>Issue Date :</b> 09.07.2021	<b>Page No 29</b>
<b>Verified By :</b> Dr. Dinoop K. P. <b>Designation:</b> Assistant Professor, Microbiology	<b>Signature:</b> 	<b>Revision No:</b>	<b>Copy no: Controlled</b>
<b>Issued By :</b> Dr. Kavita Raja <b>Designation:</b> Professor & Head, Microbiology	<b>Signature :</b> 	<b>ICMR Extramural Adhoc: P-5410</b>	

**Department of Microbiology**  
**Sree Chitra Tirunal Institute for Medical Sciences and Technology (SCTIMST)**

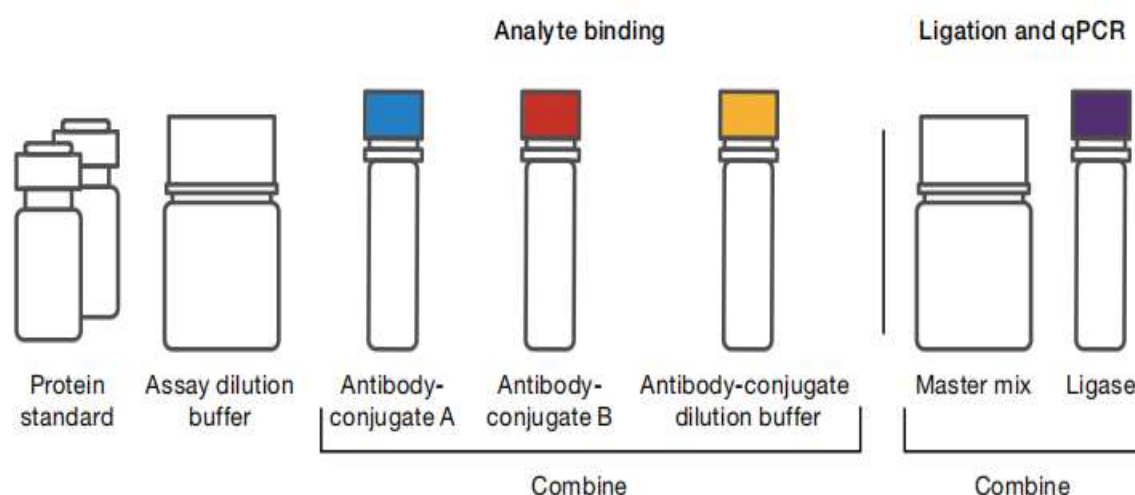

(Figure 8)

**5.5.3h. Environmental and safety controls:**

1. Wear gloves, use DNase/RNase/pyrogen free plastic ware, and practice proper DNA handling techniques.
2. Wear goggles, Lab coat, and put-up hair
3. Use UV-C germicidal lamp in the hood to sterilize the interior and contents before usage to prevent contamination of the experiment for 15 minutes before the hood is used.
4. Sterile the hood with Eco-shield prior and preposition of procedure.

**5.5.3i. Calibration procedures:** As per kit and instrument manufacturer instructions

**5.5.3j. Steps of the procedure:** Same as 5.5.3c

**5.5.3k. Quality control procedures:** As per kit and instrument manufacturer instructions

**5.5.3l. Interference:**



1. The ProQuantum immunoassay is a DNA assay, and will not perform properly if samples contain inhibitors that affect such assays (e.g., DNA ligase inhibitors).

<b>Prepared By :</b> Ms. Gopika S. L. <b>Designation:</b> Laboratory Technician (P-5410)	<b>Signature:</b> 	<b>Issue Date :</b> 09.07.2021	<b>Page No</b> 30
<b>Verified By :</b> Dr. Dinoop K. P. <b>Designation:</b> Assistant Professor, Microbiology	<b>Signature:</b> 	<b>Revision No:</b>	<b>Copy no:</b> Controlled
<b>Issued By :</b> Dr. Kavita Raja <b>Designation:</b> Professor & Head, Microbiology	<b>Signature :</b> 	<b>ICMR Extramural Adhoc: P-5410</b>	

**Department of Microbiology**  
**Sree Chitra Tirunal Institute for Medical Sciences and Technology (SCTIMST)**

2. Use a plate seal hand tool to ensure complete adherence to avoid any evaporation or contamination.
3. Use best practices with pipetting to minimize CV.
4. Use a working plate to prepare reagents and a multi-channel pipette when transferring reagents to the assay plate to minimize handling time and thus, evaporation.
5. Use a plate rack to hold the assay plate to avoid splashing when unsealing the adhesive seals.
6. Outliers are more readily identified if the assay is run in triplicate.
7. Be sure to use appropriate PCR plates that are compatible with the qPCR instrument and block type.
8. Do not vortex plates.
9. Mixing of the reagents is critical to the assay. Mixing can be performed by careful Pipetting up and down 10 times, or by striking the side of the plate against the palm of your hand or a stationary object like the lab bench. The strike should be hard enough to cause liquid to splash to the top of the adhesive seals and to the other side within the well.

**5.5.3m. Principle and procedure for calculation of results:** The amount of DNA produced is measured after each amplification cycle via fluorescent dyes, which exhibit fluorescence that is directly proportional to the number of PCR product molecules (or amplicons) generated. This graph shows the fluorescence vs. cycle number curves for four different starting protein concentrations. The dashed line represents the fluorescence threshold. The cycle number required to reach the fluorescence threshold (threshold cycle or Ct) is plotted vs. protein concentration to create a standard curve. (Figure 9)

<b>Prepared By :</b> Ms. Gopika S. L. <b>Designation:</b> Laboratory Technician (P-5410)	<b>Signature:</b> 	<b>Issue Date :</b> 09.07.2021	<b>Page No</b> 31
<b>Verified By :</b> Dr. Dinoop K. P. <b>Designation:</b> Assistant Professor, Microbiology	<b>Signature:</b> 	<b>Revision No:</b>	<b>Copy no:</b> <b>Controlled</b>
<b>Issued By :</b> Dr. Kavita Raja <b>Designation:</b> Professor & Head, Microbiology	<b>Signature :</b> 	<b>ICMR Extramural Adhoc: P-5410</b>	

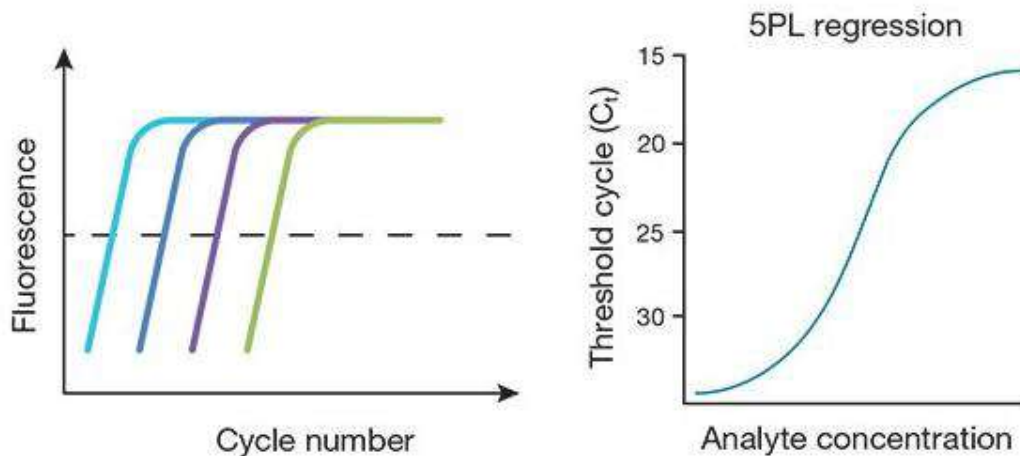

(Figure 9)

**5.5.3n. Biological reference intervals:** 0.064 – 10000 pg/mL

**5.5.3o Reportable interval of examination results:** 2 hr

**5.5.3p. Instructions to determine quantitative results (if not within measurement interval):** Serial doubling dilutions

**5.5.3q. Critical values/alerts:** >100 pg/mL

**5.5.3r. Laboratory clinical interpretation:**

**Raised CSF IL-17A:** Indicative of Gram-positive bacterial infection <sup>[4]</sup>

**5.5.3s. Potential sources of variation:** Nil

**5.5.3t. References:**

1. Product Sheet: ProQuantum Human IL-17A Immunoassay Kit
2. Quick Reference: ProQuantum Human IL-17A Immunoassay Kit
3. User Guide: ProQuantum Human IL-17A Immunoassay Kit
1. Abudeev SA, Kiselev KV, Kruglyakov NM, Belousova KA, Lobanova IN, Parinov OV, et al. Cerebrospinal Fluid Presepsin As a Marker of Nosocomial Infections of the Central Nervous System: A Prospective Observational Study. Front Neurol 2018;9:58.

<b>Prepared By :</b> Ms. Gopika S. L. <b>Designation:</b> Laboratory Technician (P-5410)	<b>Signature:</b> 	<b>Issue Date :</b> 09.07.2021	<b>Page No</b> 32
<b>Verified By :</b> Dr. Dinoop K. P. <b>Designation:</b> Assistant Professor, Microbiology	<b>Signature:</b> 	<b>Revision No:</b>	<b>Copy no:</b> Controlled
<b>Issued By :</b> Dr. Kavita Raja <b>Designation:</b> Professor & Head, Microbiology	<b>Signature :</b> 	<b>ICMR Extramural Adhoc: P-5410</b>	

### **3. Human procalcitonin (PCT) assay**

#### **5.5.3a. Purpose of the examination:**

To determine the concentration of PCT (Procalcitonin) in human serum and cerebrospinal fluid (CSF)



#### **5.5.3b. Principle and method of examination:**

The B·R·A·H·M·S PCT sensitive KRYPTOR® is a **homogeneous sandwich immunoassay** for detection of PCT in human serum or plasma. The measuring principle is based on **Time-Resolved Amplified Cryptate Emission (TRACE) technology**, which measures the signal that is emitted from an immunocomplex with time delay.

#### **Measuring Principle**

The basis of the TRACE technology is a non-radiative energy transfer from a donor [a cage-like structure with a europium ion in the center (cryptate)] to an acceptor (XL 665). The proximity of donor (cryptate) and acceptor (XL 665) in a formed immunocomplex and the spectral overlap between donor emission and acceptor absorption spectra on the one hand intensifies the fluorescent signal and on the other hand extends the life span of the acceptor signal, allowing for the measurement of temporally delayed fluorescence.

After the sample to be measured has been excited with a nitrogen laser at 337 nm, the donor (cryptate) emits a long-life fluorescent signal in the milli-second range at 620 nm, while the acceptor (XL 665) generates a short-life signal in the range of nano-seconds at 665 nm. When both components are bound in an immunocomplex, both the signal amplification and the prolonged life span of the acceptor signal occur at 665 nm, and the life span is in the microsecond range. This delayed acceptor signal is proportional to the concentration of the

<b>Prepared By :</b> Ms. Gopika S. L. <b>Designation:</b> Laboratory Technician (P-5410)	<b>Signature:</b> 	<b>Issue Date :</b> 09.07.2021	<b>Page No</b> 33
<b>Verified By :</b> Dr. Dinoop K. P. <b>Designation:</b> Assistant Professor, Microbiology	<b>Signature:</b> 	<b>Revision No:</b>	<b>Copy no:</b> <b>Controlled</b>
<b>Issued By :</b> Dr. Kavita Raja <b>Designation:</b> Professor & Head, Microbiology	<b>Signature :</b> 	<b>ICMR Extramural Adhoc: P-5410</b>	

**Department of Microbiology**  
**Sree Chitra Tirunal Institute for Medical Sciences and Technology (SCTIMST)**

analyte to be measured. The specific fluorescence which is proportional to the antigen concentration is obtained through a double selection: spectral (separation depending on wave-length) and temporal (time resolved measurement). This enables an exclusive measurement of the signal emitted by the immunological complex and the ratio between the two wave lengths (665/620) allows a real-time correction of the variations in optic transmission from the medium. See Figures 1 and 2.

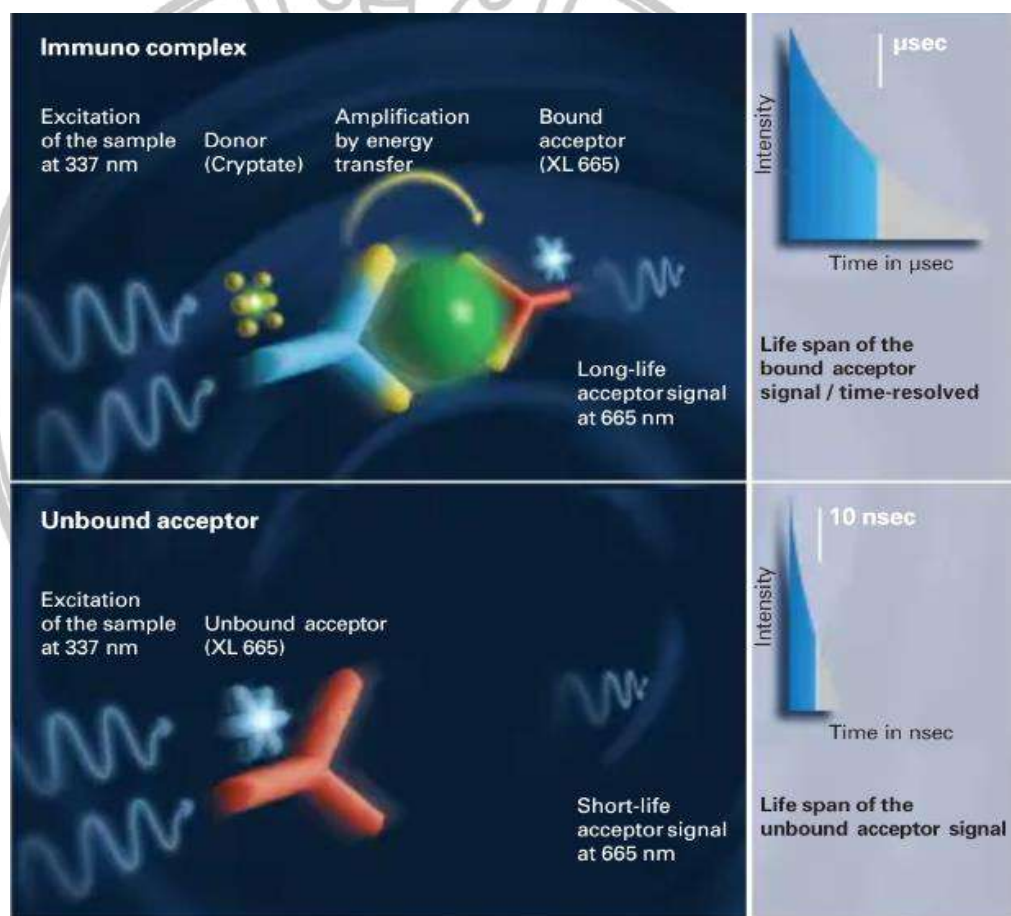

(Figure 1)

<b>Prepared By :</b> Ms. Gopika S. L. <b>Designation:</b> Laboratory Technician (P-5410)	<b>Signature:</b> 	<b>Issue Date :</b> 09.07.2021	<b>Page No</b> 34
<b>Verified By :</b> Dr. Dinoop K. P. <b>Designation:</b> Assistant Professor, Microbiology	<b>Signature:</b> 	<b>Revision No:</b>	<b>Copy no:</b> <b>Controlled</b>
<b>Issued By :</b> Dr. Kavita Raja <b>Designation:</b> Professor & Head, Microbiology	<b>Signature :</b> 	<b>ICMR Extramural Adhoc: P-5410</b>	

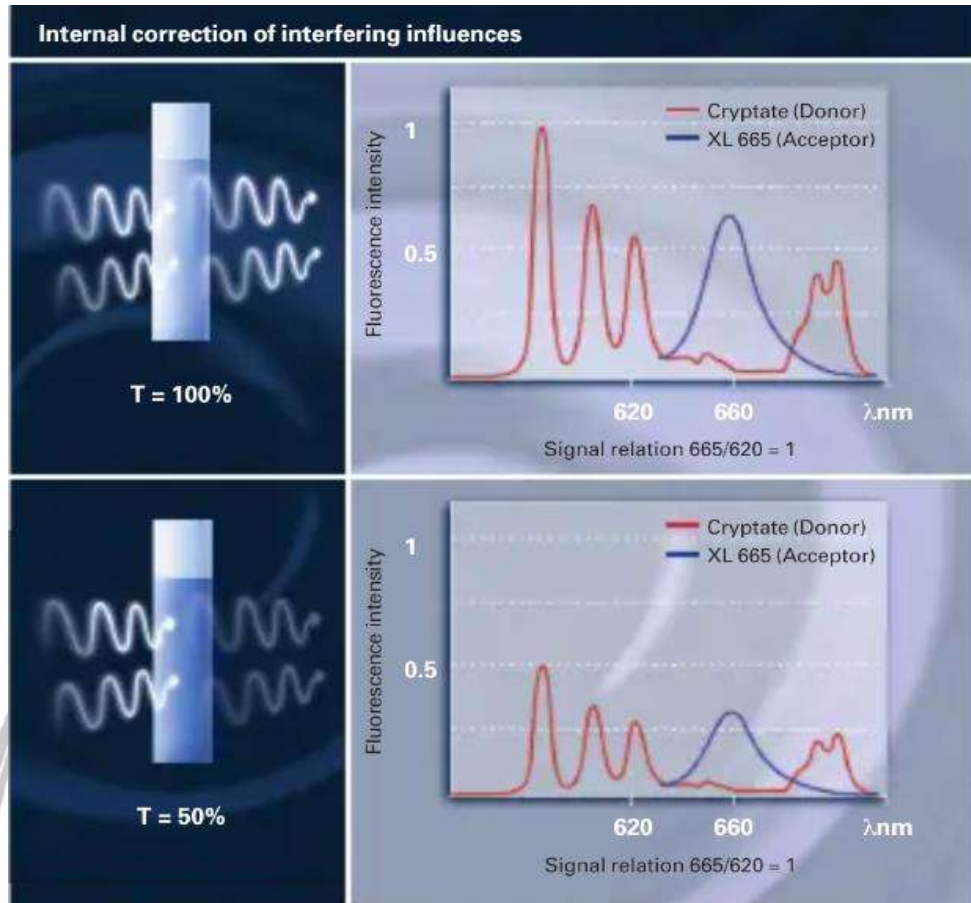

(Figure 2)

The B·R·A·H·M·S PCT sensitive KRYPTOR is a homogenous immunoassay and does not require separation or washing steps. It is thus possible to obtain data without interrupting the immunological reaction. High concentration samples (> 50 µg/L) are detected in the first few seconds of incubation and may be diluted by the appropriate dilution factor, then re-assayed automatically.

The molecules of PCT present in the patient samples are sandwiched between the antibodies of the immunoassay. Thus, the intensity of the signal is proportional to the amount of PCT.

<b>Prepared By :</b> Ms. Gopika S. L. <b>Designation:</b> Laboratory Technician (P-5410)	<b>Signature:</b> 	<b>Issue Date :</b> 09.07.2021	<b>Page No</b> 35
<b>Verified By :</b> Dr. Dinoop K. P. <b>Designation:</b> Assistant Professor, Microbiology	<b>Signature:</b> 	<b>Revision No:</b>	<b>Copy no:</b> Controlled
<b>Issued By :</b> Dr. Kavita Raja <b>Designation:</b> Professor & Head, Microbiology	<b>Signature :</b> 	<b>ICMR Extramural Adhoc: P-5410</b>	

**Department of Microbiology**  
**Sree Chitra Tirunal Institute for Medical Sciences and Technology (SCTIMST)**

**5.5.3c. Procedure of the examination:**

1. Registering and/or loading the sample(s), reagent kit, calibrator and controls as applicable.
2. A sample volume of 50 µL is needed for each test.
3. A work-list for the day is created, Then the test is started.
4. The sample probe of the analyzer pipettes and dispenses the conjugates from the reagent kit and the sample into the wells.
5. The probe is heated to incubate the reagent-sample mixture so it is at reaction temperature (37 °C) prior to dispensing and mixing in the reaction well.
6. After measurement of the fluorescent signal, the data obtained from the software is compared to the memorized standard curve.
7. Incubation lasts 19 minutes.
8. If a sample presents a concentration higher than that of the direct reading zone (i.e., > 50 µg/L), it is detected in the first few seconds of incubation, diluted and re-assayed automatically. After measurement of the fluorescent signal, the program compares each result obtained with the stored standard curve.

**5.5.3d. Type of sample:** Cerebrospinal fluid (CSF), Serum or Plasma [EDTA or Heparin]

**5.5.3e. Patient preparation:** As per sample collection manual



1. Clinical and Laboratory Standards Institute (CLSI) guidelines followed for collecting, transporting, and processing patient samples.
2. There is no difference between the use of glass and plastic collecting tube types.

**5.5.3f. Type of container and additives:**

**Plasma [EDTA Tube or Heparin Tube]**

**Serum [Red-top tube]**

**Body fluids -CSF [Sterile container]**

<b>Prepared By :</b> Ms. Gopika S. L. <b>Designation:</b> Laboratory Technician (P-5410)	<b>Signature:</b> 	<b>Issue Date :</b> 09.07.2021	<b>Page No 36</b>
<b>Verified By :</b> Dr. Dinoop K. P. <b>Designation:</b> Assistant Professor, Microbiology	<b>Signature:</b> 	<b>Revision No:</b>	<b>Copy no: Controlled</b>
<b>Issued By :</b> Dr. Kavita Raja <b>Designation:</b> Professor & Head, Microbiology	<b>Signature :</b> 	<b>ICMR Extramural Adhoc: P-5410</b>	

**Department of Microbiology**  
**Sree Chitra Tirunal Institute for Medical Sciences and Technology (SCTIMST)**

**5.5.3g. Required equipment and reagents:**



Reagent	Quantity for 50 determinations	Content
Cryptate Conjugate	1 bottle lyophilized	Cryptate conjugate, cryptate labeled, anti-PCT antibody (polyclonal, sheep), 3.2 mL after reconstitution with KRYPTOR Solution 1 and KRYPTOR Solution 2
XL665 Conjugate	1 bottle lyophilized	XL665 conjugate, XL665 labeled, anti-PCT antibody (monoclonal, mouse), 3.95 mL after reconstitution with KRYPTOR Solution 1 and KRYPTOR Solution 2
Diluent	1 bottle	Defibrinated human plasma, for diluting samples above 50 µg/L, ready for use

**1. Calibrator:**

	Content
Calibrator	Lyophilized recombinant PCT in defibrinated human plasma, reconstitute with 0.75 mL deionized water with conductivity of less than 50 µS/cm [range: 22.5 – 27.5 µg/L]

**2. Controls:**

	Content
Control 1	PCT control 1, lyophilized recombinant PCT in defibrinated human plasma, reconstitute with 2 mL de-ionized water with conductivity of less than 50 µS/cm [range: 0.2 – 0.4 µg/L]

<b>Prepared By :</b> Ms. Gopika S. L. <b>Designation:</b> Laboratory Technician (P-5410)	<b>Signature:</b> 	<b>Issue Date :</b> 09.07.2021	<b>Page No</b> 37
<b>Verified By :</b> Dr. Dinoop K. P. <b>Designation:</b> Assistant Professor, Microbiology	<b>Signature:</b> 	<b>Revision No:</b>	<b>Copy no:</b> Controlled
<b>Issued By :</b> Dr. Kavita Raja <b>Designation:</b> Professor & Head, Microbiology	<b>Signature :</b> 	<b>ICMR Extramural Adhoc: P-5410</b>	

**Department of Microbiology**  
**Sree Chitra Tirunal Institute for Medical Sciences and Technology (SCTIMST)**

Control 2	PCT control 2, lyophilized recombinant PCT in defibrinated human plasma, reconstitute with 2 mL de-ionized water with conductivity of less than 50 $\mu\text{S/cm}$ [range: 8 – 12 $\mu\text{g/L}$ ]
-----------	--

Consumables	
KRYPTOR Solution 1	ProClin 150 Solution
KRYPTOR Solution 2	Potassium fluoride solution
KRYPTOR Solution 3	Active chlorine and sodium hydroxide solution
KRYPTOR Solution 4	Sodium hydroxide solution
KRYPTOR BUFFER	Phosphate Buffer Saline (PBS) buffer, not reconstituted, 5 liters after reconstitution

3. Consumables:

4. Reaction plates KRYPTOR

5. Dilution plates KRYPTOR



**5.5.3h. Environmental and safety controls:**

1. Wear protective clothing, protective gloves and safety glasses at work.

2. Do not pipete my mouth.

3. Wash hands after work.

4. This reagent contains materials of human origin (e.g. human serum). These materials have been screened for HBsAg, HIV I/II antibodies, and HCV antibodies; all tests were negative. However, the reagent and patient samples should be handled with care, as all materials of human origin are potentially hazardous.

<b>Prepared By :</b> Ms. Gopika S. L. <b>Designation:</b> Laboratory Technician (P-5410)	<b>Signature:</b> 	<b>Issue Date :</b> 09.07.2021	<b>Page No 38</b>
<b>Verified By :</b> Dr. Dinoop K. P. <b>Designation:</b> Assistant Professor, Microbiology	<b>Signature:</b> 	<b>Revision No:</b>	<b>Copy no: Controlled</b>
<b>Issued By :</b> Dr. Kavita Raja <b>Designation:</b> Professor & Head, Microbiology	<b>Signature :</b> 	<b>ICMR Extramural Adhoc: P-5410</b>	

**Department of Microbiology**  
**Sree Chitra Tirunal Institute for Medical Sciences and Technology (SCTIMST)**

5. The conjugates contain potassium fluoride, and are dangerous both in skin contact and ingestion. In case of contact with the eyes, immediately wash thoroughly and consult a specialist.

6. Glass vials are included in the kit, we explicitly point out that there will be a breakage hazard, and consequently a risk of injury.



**5.5.3i. Calibration procedures:**

1. KRYPTOR CAL is designed to readjust the standard curve memorized in the B·R·A·H·M·S KRYPTOR analyzer.
2. Reconstitute a vial with de-ionized water (0.75 mL) as indicated on the vial label. Use de-ionized water with conductivity of less than 50  $\mu\text{S}/\text{cm}$ .
3. Mix gently after reconstitution.
4. Do not leave the calibrator/calibrators at room temperature or on the carousel for more than 4 hours.

**5.5.3j. Steps of the procedure:**

1. Select the calibrator lot and add to work list.
2. Request a carousel hood opening and place the calibrator tube on the sample carousel making sure the bar-code fills the slot then start the instrument.
3. The standard curve is included with the bar code information from the calibration card and is stored in the analyzer.
4. The curve obtained from a calibration, may be viewed on the analyzer screen.
5. Measures concentrations between 0.02 and 5000  $\mu\text{g}/\text{L}$ . The Limit of Quantification is 0.075  $\mu\text{g}/\text{L}$  (with bias  $\leq 5\%$ , % CV  $\leq 15\%$  and total error  $\leq 30\%$ ).

**5.5.3k. Quality control procedures:**

<b>Prepared By :</b> Ms. Gopika S. L. <b>Designation:</b> Laboratory Technician (P-5410)	<b>Signature:</b> 	<b>Issue Date :</b> 09.07.2021	<b>Page No</b> 39
<b>Verified By :</b> Dr. Dinoop K. P. <b>Designation:</b> Assistant Professor, Microbiology	<b>Signature:</b> 	<b>Revision No:</b>	<b>Copy no:</b> Controlled
<b>Issued By :</b> Dr. Kavita Raja <b>Designation:</b> Professor & Head, Microbiology	<b>Signature :</b> 	<b>ICMR Extramural Adhoc: P-5410</b>	

**Department of Microbiology**  
**Sree Chitra Tirunal Institute for Medical Sciences and Technology (SCTIMST)**

1. QC kit contains 2 series of 3 vials, a bar code card, bar code stick-on labels, the concentration ranges by level.

2. Each vial contains lyophilized recombinant PCT in defibrinated human plasma. The two series of vials correspond to two levels of antigen concentration.

B·R·A·H·M·S PCT sensitive KRYPTOR® - Control 1 (level 1): 0.2 – 0.4 µg/L

B·R·A·H·M·S PCT sensitive KRYPTOR® - Control 2 (level 2): 8 – 12 µg/L

3. Reconstitute a vial with de-ionized water (2.0mL) as indicated on the vial label. Use de-ionized water with conductivity of less than 50 µS/cm.

4. Allow 15 minutes for the complete dissolution of the lyophilisate.

5. Homogenize the control sample using a Vortex.

6. Transfer aliquots into sample tubes.

7. Use one sample tube for immediate measurements. Freeze the other tubes immediately at <-16 °C and store up to one month.

8. After thawing an aliquot, mix using a Vortex and use immediately for measurement. A control tube will be processed like a sample tube.

9. These samples must be processed exactly the same way as the patient sample.

10. Analyzer family can automatically check the quality of control results at intervals, by statistical analysis on Levey Jennings graphs.



11. Control material should be tested in accordance with guidelines or requirements of local, state, and/or federal regulations or accrediting organizations

12. After reconstitution, do not keep a vial more than four (4) hours at 18-25 °C or 24 hours at 28 °C. Once thawed, a control aliquot must not be refrozen.

**5.5.3I. Interferences:**

1. Citrate plasma tubes should not be used as PCT concentrations are underestimated.

2. Icteric, hemolytic or hyperlipemic samples, or samples which are turbid or contain fibrin may yield imprecise results.

<b>Prepared By :</b> Ms. Gopika S. L. <b>Designation:</b> Laboratory Technician (P-5410)	<b>Signature:</b> 	<b>Issue Date :</b> 09.07.2021	<b>Page No</b> 40
<b>Verified By :</b> Dr. Dinoop K. P. <b>Designation:</b> Assistant Professor, Microbiology	<b>Signature:</b> 	<b>Revision No:</b>	<b>Copy no:</b> Controlled
<b>Issued By :</b> Dr. Kavita Raja <b>Designation:</b> Professor & Head, Microbiology	<b>Signature :</b> 	<b>ICMR Extramural Adhoc: P-5410</b>	

**Department of Microbiology**  
**Sree Chitra Tirunal Institute for Medical Sciences and Technology (SCTIMST)**

3. Samples that are not used in an assay within 24 hours following the drawing of a blood sample must be frozen and stored at - 20°C.
4. Samples may be frozen thawed three times.

**5.5.3m. Principle and procedure for calculation of results:**

After measurement of the fluorescent signal, the data obtained from the software is compared to the memorized standard curve. The B·R·A·H·M·S PCT sensitive KRYPTOR PCT results are given in µg/L.

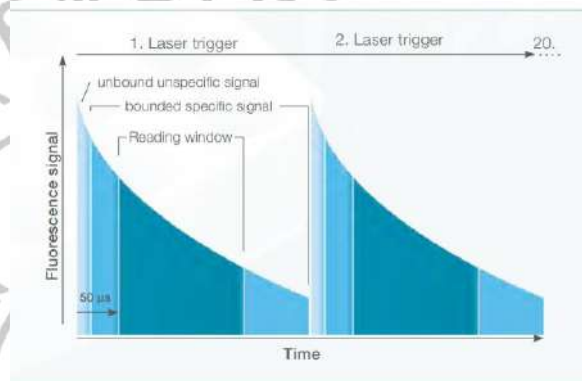

Correlation to reference assay Thermo Scientific B·R·A·H·M·S PCT LIA

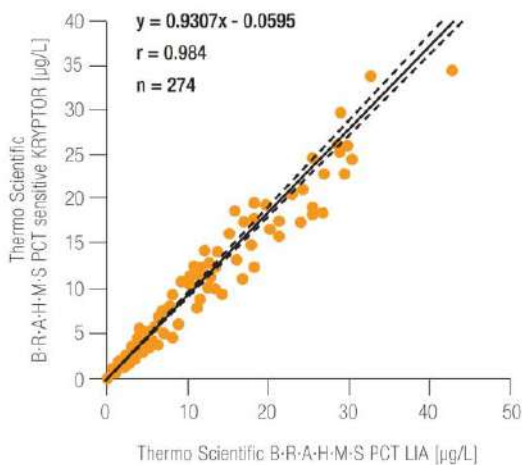

**(Figure 3)**



**(Figure 4)**

<b>Prepared By :</b> Ms. Gopika S. L. <b>Designation:</b> Laboratory Technician (P-5410)	<b>Signature:</b> 	<b>Issue Date :</b> 09.07.2021	<b>Page No</b> 41
<b>Verified By :</b> Dr. Dinoop K. P. <b>Designation:</b> Assistant Professor, Microbiology	<b>Signature:</b> 	<b>Revision No:</b>	<b>Copy no:</b> Controlled
<b>Issued By :</b> Dr. Kavita Raja <b>Designation:</b> Professor & Head, Microbiology	<b>Signature :</b> 	<b>ICMR Extramural Adhoc: P-5410</b>	

**Department of Microbiology**  
**Sree Chitra Tirunal Institute for Medical Sciences and Technology (SCTIMST)**

**5.3n. Biological reference intervals:** <0.05 ng/ml

**5.5.3o Reportable interval of examination results :** 19 min

**5.5.3p. Instructions to determine quantitative results** (if not within measurement interval):

Measuring range with automatic dilution **0.02 to 5000 µg/L**

**5.5.3q. Critical values/alerts:**

>0.5 ng/ml – Indicative of bacterial infection (Serum & CSF)

**5.5.3r. Laboratory clinical interpretation:**

**1. Risk assessment for progression to severe sepsis and septic shock**



The B·R·A·H·M·S PCT sensitive KRYPTOR® is intended to aid in the risk assessment of critically ill patients on their first day of ICU admission for progression to severe sepsis and septic shock. SIRS, Sepsis, Severe Sepsis, and Septic Shock were categorized according to the criteria of the consensus conference of the American College of Chest Physicians/Society of Critical Care Medicine. PCT should always be interpreted in the clinical context of the patient. Therefore, clinicians should use the PCT results in conjunction with other laboratory findings and clinical signs of the patient. Data support the following interpretative risk assessment criteria

**PCT > 2 µg/L**

A PCT level above 2.0 µg/L on the first day of ICU admission is associated with a high risk for progression to severe sepsis and/or septic shock.

**PCT < 0.5 µg/L**

A PCT level below 0.5 µg/L on the first day of ICU admission is associated with a low risk for progression to severe sepsis and/or septic shock.

<b>Prepared By :</b> Ms. Gopika S. L. <b>Designation:</b> Laboratory Technician (P-5410)	<b>Signature:</b> 	<b>Issue Date :</b> 09.07.2021	<b>Page No</b> 42
<b>Verified By :</b> Dr. Dinoop K. P. <b>Designation:</b> Assistant Professor, Microbiology	<b>Signature:</b> 	<b>Revision No:</b>	<b>Copy no:</b> <b>Controlled</b>
<b>Issued By :</b> Dr. Kavita Raja <b>Designation:</b> Professor & Head, Microbiology	<b>Signature :</b> 	<b>ICMR Extramural Adhoc: P-5410</b>	

**Department of Microbiology**  
**Sree Chitra Tirunal Institute for Medical Sciences and Technology (SCTIMST)**

**Note:** PCT levels below 0.5 µg/L do not exclude an infection, because localized infections (without systemic signs) may also be associated with such low levels. If the PCT measurement is done very early after the systemic infection process has started (usually 6 hours), these values may still be low.



Various non-infectious conditions are known to induce changes in PCT level, PCT levels between 0.5 µg/L and 2.0 µg/L should be interpreted in the context of the specific clinical background and condition(s) of the individual patient. It is recommended to retest PCT within 6-24hrs if any concentrations <2.0 µg/L are obtained.

**5.5.3s. Potential sources of variation:** Nil

**5.5.3t. References:**

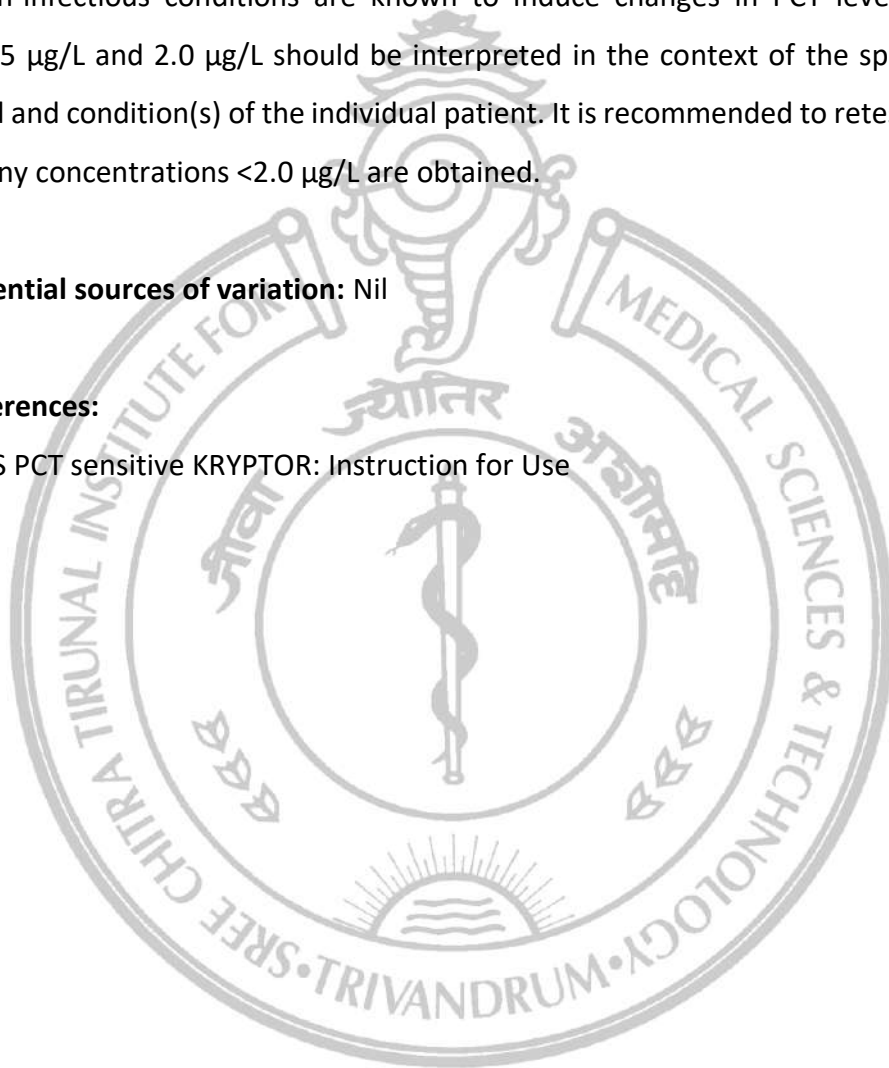
B·R·A·H·M·S PCT sensitive KRYPTOR: Instruction for Use



<b>Prepared By :</b> Ms. Gopika S. L. <b>Designation:</b> Laboratory Technician (P-5410)	<b>Signature:</b> 	<b>Issue Date :</b> 09.07.2021	<b>Page No</b> 43
<b>Verified By :</b> Dr. Dinoop K. P. <b>Designation:</b> Assistant Professor, Microbiology	<b>Signature:</b> 	<b>Revision No:</b>	<b>Copy no:</b> Controlled
<b>Issued By :</b> Dr. Kavita Raja <b>Designation:</b> Professor & Head, Microbiology	<b>Signature :</b> 	<b>ICMR Extramural Adhoc: P-5410</b>	

#### 4.Lactic Acid estimation

##### 5.5.3a. Purpose of the examination:

The LA method used on the Dimension® clinical chemistry system is an enzymatic in vitro diagnostic test intended for the quantitative measurement of lactic acid in human plasma and cerebrospinal fluid (CSF). Lactic acid test results may be used as an aid in the diagnosis and treatment of lactic acidosis.

##### 5.5.3b. Principle and method of examination:

The Lactic Acid method is a modification of the Marbach and Weil method,<sup>1</sup> which employs the oxidation of lactate to pyruvate.



Rabbit muscle Lactic Dehydrogenase (LDH) catalyzes the oxidation of L-Lactate to Pyruvate with simultaneous reduction of nicotinamide adenine dinucleotide (NAD). One mole of NAD is converted to one mole of NADH for each mole (equivalent) of lactate present. The absorbance due to NADH is directly proportional to the lactate concentration and is measured using a two-filter (340 – 383 nm) bichromatic end point technique.



Hydrazine is used to trap the pyruvate (as a Hydrazone) as it is formed, thus driving the reaction to completion.

##### 5.5.3c. Procedure of the examination:

The sample container (if not a primary tube) must contain sufficient quantity to accommodate the sample volume plus the dead volume. Precise container filling is not required.

<b>Prepared By :</b> Ms. Gopika S. L. <b>Designation:</b> Laboratory Technician (P-5410)	<b>Signature:</b> 	<b>Issue Date :</b> 09.07.2021	<b>Page No</b> 44
<b>Verified By :</b> Dr. Dinoop K. P. <b>Designation:</b> Assistant Professor, Microbiology	<b>Signature:</b> 	<b>Revision No:</b>	<b>Copy no:</b> Controlled
<b>Issued By :</b> Dr. Kavita Raja <b>Designation:</b> Professor & Head, Microbiology	<b>Signature :</b> 	<b>ICMR Extramural Adhoc: P-5410</b>	

**Department of Microbiology**  
**Sree Chitra Tirunal Institute for Medical Sciences and Technology (SCTIMST)**

Sample Size	4 $\mu$ L
Reagent 1 Volume	158 $\mu$ L
Reagent 2 Volume	20 $\mu$ L
Reagent 3 Volume	75 $\mu$ L
Reagent 4 Volume	20 $\mu$ L
Diluent Volume	197 $\mu$ L

Sampling, reagent delivery, mixing, processing are performed by the **Dimension**<sup>®</sup> clinical chemistry system at a temperature 37 °C



The absorbance is measured at a Wavelength of 340 and 383 nm bichromatic endpoint technique

Type of Measurement: Bichromatic, end point and printing of results are automatically performed by the **Dimension**<sup>®</sup> clinical chemistry system

**5.5.3d. Type of sample: CSF**

**5.5.3e. Patient preparation:**

1. Fasting blood is best collected without stasis in a container of sodium fluoride/ potassium oxalate, followed by immediate chilling of the specimen and separation of the cells within 15 minutes.
2. Normal procedures for the collection of cerebrospinal fluid may be used for specimens to be analyzed by the LA method.
3. Avoid hemolysis. Keep sample on ice and analyze promptly. If testing cannot be performed immediately, refrigerate the separated plasma sample for up to 24 hours or freeze it for up to 1 month.
4. Blood collection tubes containing sodium iodoacetate may be used for the LA method.

<b>Prepared By :</b> Ms. Gopika S. L. <b>Designation:</b> Laboratory Technician (P-5410)	<b>Signature:</b> 	<b>Issue Date :</b> 09.07.2021	<b>Page No</b> 45
<b>Verified By :</b> Dr. Dinoop K. P. <b>Designation:</b> Assistant Professor, Microbiology	<b>Signature:</b> 	<b>Revision No:</b>	<b>Copy no:</b> Controlled
<b>Issued By :</b> Dr. Kavita Raja <b>Designation:</b> Professor & Head, Microbiology	<b>Signature :</b> 	<b>ICMR Extramural Adhoc: P-5410</b>	

**Department of Microbiology**  
**Sree Chitra Tirunal Institute for Medical Sciences and Technology (SCTIMST)**

**5.5.3f. Type of container and additives:**

**CSF: Sterile container**

**Plasma: Grey Top Tube (NaF/K<sub>2</sub>C<sub>2</sub>O<sub>4</sub>/C<sub>2</sub>H<sub>2</sub>INaO<sub>2</sub>)**

**5.5.3g. Required equipment and reagents:**

**Reagents:**

Wells	Form	Ingredient	Concentration	Source
1,2	Tablet	NAD	2.0 μM	
3,4	Liquid	Dihydrazine Sulfate	3.7 μM	
5,6	Liquid	LDH	40 U	Rabbit
7,8	Liquid	Tris buffer	0.24 mM	

1. Wells are numbered consecutively from the wide end of the cartridge.
2. Nominal final value per test at manufacture.



**(Flex Reagent Cartridge)**

<b>Prepared By :</b> Ms. Gopika S. L. <b>Designation:</b> Laboratory Technician (P-5410)	<b>Signature:</b> 	<b>Issue Date :</b> 09.07.2021	<b>Page No</b> 46
<b>Verified By :</b> Dr. Dinoop K. P. <b>Designation:</b> Assistant Professor, Microbiology	<b>Signature:</b> 	<b>Revision No:</b>	<b>Copy no:</b> Controlled
<b>Issued By :</b> Dr. Kavita Raja <b>Designation:</b> Professor & Head, Microbiology	<b>Signature :</b> 	<b>ICMR Extramural Adhoc: P-5410</b>	

**Department of Microbiology**  
**Sree Chitra Tirunal Institute for Medical Sciences and Technology (SCTIMST)**

**5.5.3h. Environmental and safety controls:**

1. Used cuvettes contain human body fluids; handle with appropriate care to avoid skin contact and ingestion.
2. Harmful if swallowed, in contact with skin or if inhaled. May cause an allergic skin reaction. May cause cancer. Very toxic to aquatic life with long lasting effects.
3. Wear protective gloves/protective clothing/eye protection/face protection.
4. IF INHALED: Remove victim to fresh air and keep at rest in a position comfortable for breathing. Dispose of contents and container in accordance with all local, regional, and national regulations.
5. **Contains:** Hydrazine sulfate, Benzalkonium chloride, Obtain special instructions before use.

**5.5.3i. Calibration procedures:** As per kit and instrument manufacturer instructions

**5.5.3j. Steps of the procedure:** Same as 5.5.3c



**5.5.3k. Quality control procedures:** As per kit and instrument manufacturer instructions

**5.5.3l. Interferences:**

Heparinized plasma is not recommended. Higher results will be obtained due to the absence of antiglycolytic agent in the blood collection tubes.

**5.5.3m. Principle and procedure for calculation of results:**

1. The absorbance due to NADH is directly proportional to the lactate concentration and is measured using a two-filter (340 – 383 nm) Bichromatic end point technique.
2. The instrument automatically calculates and prints the concentration of LA in mmol/L using the calculation scheme
3. Results of this test should always be interpreted in conjunction with the patient's medical history, clinical presentation and other findings.

<b>Prepared By :</b> Ms. Gopika S. L. <b>Designation:</b> Laboratory Technician (P-5410)	<b>Signature:</b> 	<b>Issue Date :</b> 09.07.2021	<b>Page No 47</b>
<b>Verified By :</b> Dr. Dinoop K. P. <b>Designation:</b> Assistant Professor, Microbiology	<b>Signature:</b> 	<b>Revision No:</b>	<b>Copy no: Controlled</b>
<b>Issued By :</b> Dr. Kavita Raja <b>Designation:</b> Professor & Head, Microbiology	<b>Signature :</b> 	<b>ICMR Extramural Adhoc: P-5410</b>	

**Department of Microbiology**  
**Sree Chitra Tirunal Institute for Medical Sciences and Technology (SCTIMST)**

4. Analytical Measurement Range (AMR): 0.3 – 15 mmol/L

This is the range of analyte values that can be directly measured on the specimen without any dilution or pretreatment that is not part of the usual analytical process and is equivalent to the assay range.

Samples with results more than 15 mmol/L should be repeated on dilution.

Manual Dilution: Make appropriate dilutions with Reagent grade water to obtain result within the assay range. Enter dilution factor. Reassay. Resulting readout is corrected for dilution.

Autodilution (AD). Results less than 0.3 mmol/L should be reported as “less than 0.3 mmol/L” instead of the numerical value.

**5.5.3n. Biological reference intervals:**

**Venous plasma:** 0.4 – 2.0 mmol/L

**Cerebrospinal fluid:** 0.6 – 2.2 mmol/L

**5.5.3o Reportable interval of examination results:** 0.3-15 mmol/L

**5.5.3p. Instructions to determine quantitative results** (if not within measurement interval):

**5.5.3q. Critical values/alerts:** >2.2 mmol/L



**5.5.3r. Laboratory clinical interpretation:**

1. Intravenous injection of epinephrine, glucose, bicarbonate, or other infusions that modify the acid-base balance causes elevation in lactate (and also pyruvate) levels not necessarily related to hypoxia
2. Lipemia (Intralipid®) at 3000 mg/dL [33.9 mmol/L] tripped a test report message; therefore, the magnitude of the interference could not be determined.

**5.5.3s. Potential sources of variation:** Nil

**5.5.3t. References:**

SIEMENS Dimension Clinical Chemistry System: Reference Material.

<b>Prepared By :</b> Ms. Gopika S. L. <b>Designation:</b> Laboratory Technician (P-5410)	<b>Signature:</b> 	<b>Issue Date :</b> 09.07.2021	<b>Page No</b> 48
<b>Verified By :</b> Dr. Dinoop K. P. <b>Designation:</b> Assistant Professor, Microbiology	<b>Signature:</b> 	<b>Revision No:</b>	<b>Copy no:</b> <b>Controlled</b>
<b>Issued By :</b> Dr. Kavita Raja <b>Designation:</b> Professor & Head, Microbiology	<b>Signature :</b> 	<b>ICMR Extramural Adhoc: P-5410</b>	

## 5. Human Presepsin ELISA

### 5.5.3a. Purpose of the examination:

For quantitative detection of Presepsin in serum, plasma, tissue homogenates and other biological fluids using **sandwich ELISA, Double antibody technique**.

### 5.5.3b. Principle and method of examination:

This kit was based on sandwich enzyme-linked immune-sorbent assay technology. Capture antibody was pre-coated onto 96-well plates and the biotin conjugated antibody was used as detection antibodies. The standards, test samples and biotin conjugated detection antibody were added to the wells subsequently and washed with wash buffer. HRP-Streptavidin was added, and unbound conjugates were washed away with wash buffer. TMB substrates were used to visualize HRP enzymatic reaction. TMB was catalysed by HRP to produce a blue colour product that changed into yellow after adding acidic stop solution. The density of yellow is proportional to the target amount of sample captured in plate. Read the O.D. absorbance at 450nm in a microplate reader, and then the concentration of target can be calculated.

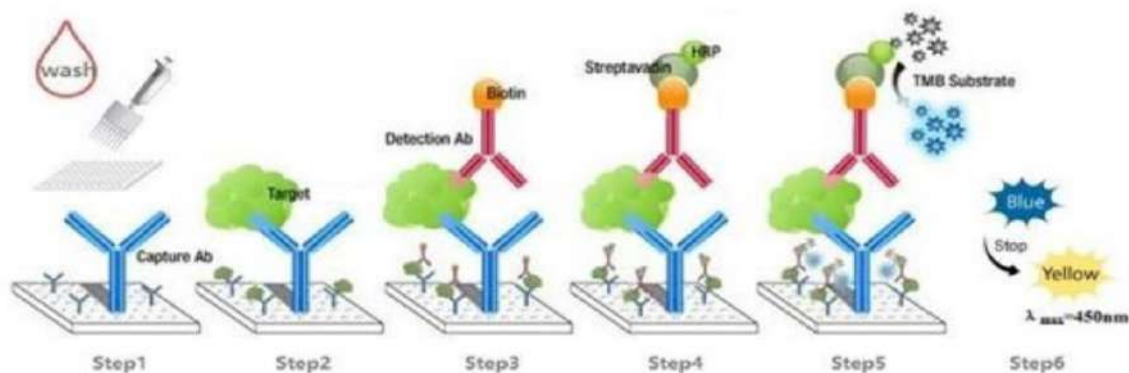

(Figure 1)

<b>Prepared By :</b> Ms. Gopika S. L. <b>Designation:</b> Laboratory Technician (P-5410)	<b>Signature:</b> 	<b>Issue Date :</b> 09.07.2021	<b>Page No</b> 49
<b>Verified By :</b> Dr. Dinoop K. P. <b>Designation:</b> Assistant Professor, Microbiology	<b>Signature:</b> 	<b>Revision No:</b>	<b>Copy no:</b> Controlled
<b>Issued By :</b> Dr. Kavita Raja <b>Designation:</b> Professor & Head, Microbiology	<b>Signature :</b> 	<b>ICMR Extramural Adhoc: P-5410</b>	

**Department of Microbiology**  
**Sree Chitra Tirunal Institute for Medical Sciences and Technology (SCTIMST)**

**5.5.3c. Procedure of the examination:**

When diluting samples and reagents, they must be mixed completely and evenly. Before adding TMB into wells, equilibrate TMB Substrate for 30 min at 37 °C. It is recommended to plot a standard curve for each test.

1. Set standard, **test samples (diluted at least 1/2 with Sample Dilution Buffer)**, control(blank) wells on the pre-coated plate respectively, and then, records their positions. It is recommended to measure each standard and sample in duplicate. **Wash plate 2 times before adding standard,**

**sample and control (blank) wells!**

1. **Prepare Standards:** Aliquot 100µl of zero tube, 1<sup>st</sup> tube, 2<sup>nd</sup> tube, 3<sup>rd</sup> tube, 4<sup>th</sup> tube, 5<sup>th</sup> tube, 6<sup>th</sup> tube and Sample Dilution Buffer (blank) into the standard wells.

3. **Add Samples:** Add 100µl of properly diluted sample into test sample wells.

4. **Incubate:** Seal the plate with a cover and incubate at 37°C for 90 minutes.

5. **Wash:** Remove the cover and discard the plate content and wash plate 2 times with Wash Buffer. Do NOT let the wells dry completely at any time.



6. **Biotin-labeled Antibody:** Add 100µl Biotin-labeled antibody working solution into above wells (standard, test sample and blank wells). Add the solution at the bottom of each well without touching the sidewall, cover the plate and incubate at 37°C for 60 minutes.9 (12)

7. **Wash:** Remove the cover, and wash plate 3 times with Wash Buffer, and let the Wash Buffer stay in the wells for 1-2 minute each time.

8. **HRP-Streptavidin Conjugate (SABC):** Add 100µl of SABC Working Solution into each well, cover the plate and incubate at 37°C for 30 minutes.

9. **Wash:** Remove the cover and wash plate 5 times with Wash Buffer and let the wash buffer stay in the wells for 1-2 minute each time.

10. **TMB Substrate:** Add 90µl TMB Substrate into each well, cover the plate and incubate at 37°C in dark within 10-20 minutes.

<b>Prepared By :</b> Ms. Gopika S. L. <b>Designation:</b> Laboratory Technician (P-5410)	<b>Signature:</b> 	<b>Issue Date :</b> 09.07.2021	<b>Page No</b> 50
<b>Verified By :</b> Dr. Dinoop K. P. <b>Designation:</b> Assistant Professor, Microbiology	<b>Signature:</b> 	<b>Revision No:</b>	<b>Copy no:</b> <b>Controlled</b>
<b>Issued By :</b> Dr. Kavita Raja <b>Designation:</b> Professor & Head, Microbiology	<b>Signature :</b> 	<b>ICMR Extramural Adhoc: P-5410</b>	

**Department of Microbiology**  
**Sree Chitra Tirunal Institute for Medical Sciences and Technology (SCTIMST)**

(**Note:** The reaction time can be shortened or extended according to the actual color change, but not more than 30minutes. You can terminate the reaction when apparent gradient appears in standard wells.)



11. **Stop:** Add 50µl Stop Solution into each well. The color will turn yellow immediately. The adding order of Stop Solution should be the same as the TMB Substrate Solution.

12. **OD Measurement:** Read the O.D. absorbance at 450 nm in Microplate Reader immediately after adding the stop solution. Regarding calculation, (the relative O.D.450) = (the O.D.450 of each well) – (the O.D.450 of blank well). The standard curve can be plotted as the relative O.D.450 of each standard solution (Y) vs. the respective concentration of the standard solution (X). The target concentration of the samples can be interpolated from the standard curve.

**Note:** If the samples measured were diluted, multiply the dilution factor to the concentrations from interpolation to obtain the concentration before dilution.

**5.5.3d. Type of sample:**

- **Serum:** Place whole blood sample at room temperature for 2 hours or put it at 4°C overnight and centrifugation for 20 minutes at approximately 1000×g, Collect the supernatant and carry out the assay immediately. Blood collection tubes should be disposable, non- pyrogenic, and non-endotoxin.
- **Plasma:** Collect plasma using EDTA-Na2 or heparin as an anticoagulant. Centrifuge samples for 15 minutes at 1000×g at 2 - 8°C within 30 minutes of collection. Collect the supernatant and carry out the assay immediately. Avoid hemolysis, high cholesterol samples.
- **Tissue Homogenates:** As hemolysis blood has relation to assay result, it is necessary to remove residual blood by washing tissue with pre-cooling PBS buffer (0.01M, pH=7.4). Mince tissue after weighing it and get it homogenized in PBS (the volume depends on the weight of the tissue. Normal, 9mL PBS would be appropriate to 1 gram tissue pieces. Some protease inhibitors are recommended to add into the PBS) with a glass 6 (12) homogenizer on ice. To

<b>Prepared By :</b> Ms. Gopika S. L. <b>Designation:</b> Laboratory Technician (P-5410)	<b>Signature:</b> 	<b>Issue Date :</b> 09.07.2021	<b>Page No</b> 51
<b>Verified By :</b> Dr. Dinoop K. P. <b>Designation:</b> Assistant Professor, Microbiology	<b>Signature:</b> 	<b>Revision No:</b>	<b>Copy no:</b> Controlled
<b>Issued By :</b> Dr. Kavita Raja <b>Designation:</b> Professor & Head, Microbiology	<b>Signature :</b> 	<b>ICMR Extramural Adhoc: P-5410</b>	

**Department of Microbiology**  
**Sree Chitra Tirunal Institute for Medical Sciences and Technology (SCTIMST)**



further break the cells, you can sonicate the suspension with an ultrasonic cell disrupter or subject it to freeze-thaw cycles. The homogenates are then centrifuged for 5 minutes at 5000×g to get the supernatant.

The total protein concentration was determined by BCA kit and the total protein concentration of each pore sample should not exceed 0.3mg.

- **Cell Culture Supernatant:** Centrifuge supernatant for 20 minutes at 1000×g at 2 - 8°C to remove insoluble impurity and cell debris. Collect the clear supernatant and carry out the assay immediately.
- **Cell Culture Lysate:** Commercial RIPA kits are recommended to follow the instructions provided. Generally, 0.5ml RIPA lysis buffer would be appropriate to 2x10<sup>6</sup> cells, DNA must be removed. The total protein concentration was determined by BCA kit and the total protein concentration of each pore sample should not exceed 0.3mg.
- **Other Biological Fluids:** Centrifuge samples for 20 minutes at 1000×g at 2-8°C. Collect supernatant and carry out the assay immediately.

**Note:** Samples to be used within 5 days can be stored at 4°C, besides that, samples must be stored at -20°C (assay ≤1 month) or -80°C (assay ≤2 months) to avoid loss of bioactivity and contamination. Avoid multiple freeze-thaw cycles. The hemolytic samples are not suitable for this assay.

- The user should estimate the concentration of target protein in the test sample and select a proper dilution factor to make the diluted target protein concentration fall in the optimal detection range of the kit. Dilute the sample with the provided dilution buffer, and several trials may be necessary. The test sample must be well mixed with the dilution buffer. Also, standard curves and sample should be tested in a pre-experiment. If samples have a very high concentration, dilute them with PBS first and then with Sample Dilution Buffer.

<b>Prepared By :</b> Ms. Gopika S. L. <b>Designation:</b> Laboratory Technician (P-5410)	<b>Signature:</b> 	<b>Issue Date :</b> 09.07.2021	<b>Page No</b> 52
<b>Verified By :</b> Dr. Dinoop K. P. <b>Designation:</b> Assistant Professor, Microbiology	<b>Signature:</b> 	<b>Revision No:</b>	<b>Copy no:</b> Controlled
<b>Issued By :</b> Dr. Kavita Raja <b>Designation:</b> Professor & Head, Microbiology	<b>Signature :</b> 	<b>ICMR Extramural Adhoc: P-5410</b>	

**Department of Microbiology**  
**Sree Chitra Tirunal Institute for Medical Sciences and Technology (SCTIMST)**

**5.5.3e. Patient preparation:** As per sample collection manual

**5.5.3f. Type of container and additives:**

**Plasma [EDTA Tube or Heparin Tube]**

**Serum [Red-top tube]**

**Other Samples [Sterile Container]**

**5.5.3g. Required equipment and reagents**



**Equipment:**

1. Micro ELISA Plate
2. Plate Sealer
3. Precision single and multi-channel pipette and disposable tips
4. Clean tubes and Eppendorf tubes.

**Reagents:**

Item	Specifications	Storage
Lyophilized Standard	2 vials	4°C/-20°C
Sample / Standard dilution buffer	20 ml	4°C
Biotin-labeled antibody (Concentrated)	120 µl	4°C
Antibody dilution buffer	10 ml	4°C
HRP-Streptavidin Conjugate (SABC)	120 µl	4°C (shading light)
SABC dilution buffer	10 ml	4°C
TMB substrate	10 ml	4°C (shading light)
Stop solution	10 ml	4°C
Wash buffer (25X)	30 ml	4°C

Bring all reagents to room temperature for 20 minutes before use.

<b>Prepared By :</b> Ms. Gopika S. L. <b>Designation:</b> Laboratory Technician (P-5410)	<b>Signature:</b> 	<b>Issue Date :</b> 09.07.2021	<b>Page No 53</b>
<b>Verified By :</b> Dr. Dinoop K. P. <b>Designation:</b> Assistant Professor, Microbiology	<b>Signature:</b> 	<b>Revision No:</b>	<b>Copy no: Controlled</b>
<b>Issued By :</b> Dr. Kavita Raja <b>Designation:</b> Professor & Head, Microbiology	<b>Signature :</b> 	<b>ICMR Extramural Adhoc: P-5410</b>	

**1. Wash Buffer**

If crystals have formed in the concentrate, you can warm it with 40°C water bath (Heating temperature should not exceed 50°C) and mix it gently until the crystals have completely been dissolved. The solution should be cooled to room temperature before use. Dilute 30ml Concentrated Wash Buffer into 750ml Wash Buffer with deionized or distilled water. Place the rest of the solution in 4°C.

**2. Standard**

i). Add 1 ml Sample Dilution Buffer into one Standard tube (labeled as zero tube), keep the tube at room temperature for 10 minutes and mix them thoroughly.

**Note: If the Standard tube concentration is higher than the range of the kit, please dilute it and label it as zero tube.**

ii). Label 7 EP tubes with 1/2, 1/4, 1/8, 1/16, 1/32, 1/64 and blank respectively. Add 0.3ml of the Sample Dilution Buffer into each tube. Add 0.3ml of the above Standard solution (from zero tube) into 1st tube and mix them thoroughly. Transfer 0.3ml from 1st tube to 2nd tube and mix them thoroughly. Transfer 0.3ml from 2nd tube to 3rd tube and mix them thoroughly, and so on. Sample Dilution Buffer was used for the blank control.

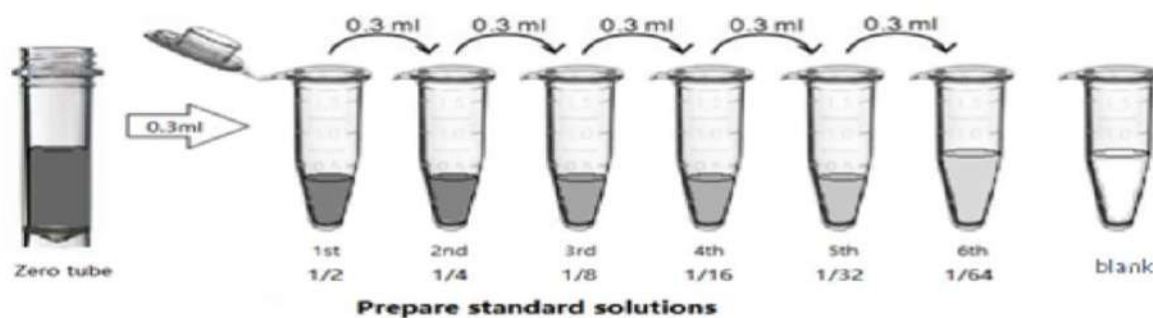

**(Figure 2)**

**Note:** It is best to use Standard Solutions within 2 hours.

<b>Prepared By :</b> Ms. Gopika S. L. <b>Designation:</b> Laboratory Technician (P-5410)	<b>Signature:</b> 	<b>Issue Date :</b> 09.07.2021	<b>Page No</b> 54
<b>Verified By :</b> Dr. Dinoop K. P. <b>Designation:</b> Assistant Professor, Microbiology	<b>Signature:</b> 	<b>Revision No:</b>	<b>Copy no:</b> Controlled
<b>Issued By :</b> Dr. Kavita Raja <b>Designation:</b> Professor & Head, Microbiology	<b>Signature :</b> 	<b>ICMR Extramural Adhoc: P-5410</b>	

### **3. Preparation of Biotin-labeled Antibody Working Solution**

Prepare it within 1 hour before experiment.

- i) Calculate required total volume of the working solution:  $0.1\text{ml} / \text{well} \times \text{quantity of wells}$ .  
(Allow 0.1-0.2ml more than the total volume)
- ii) Dilute the Biotin-detection antibody with Antibody Dilution Buffer at 1:100 and mix them thoroughly. (i.e. Add  $1\mu\text{l}$  Biotin-labeled antibody into  $99\mu\text{l}$  Antibody Dilution Buffer.)



### **4. Preparation of HRP-Streptavidin Conjugate (SABC) Working Solution:**

Prepare it within 30 minutes before experiment.

- i) Calculate required total volume of the working solution:  $0.1\text{ml} / \text{well} \times \text{quantity of wells}$   
(allow 0.1-0.2ml more than the total volume).
- ii) Dilute the SABC with SABC Dilution Buffer at 1:100 and mix them thoroughly. (i.e. Add  $1\mu\text{l}$  of SABC into  $99\mu\text{l}$  of SABC Dilution Buffer.)

#### **5.5.3h. Environmental and safety controls:**

1. Wear protective clothing, protective gloves and safety glasses at work.
2. Do not pipete by mouth.
3. Wash hands after work.
4. To inspect the validity of experiment operation and the appropriateness of sample dilution proportion, a pilot experiment using standards and a small number of samples is recommended.
5. After opening and before using, keep plate dry.
6. Before using the kit, briefly spin the tubes with the components.
7. Store TMB reagents away from light.
8. The washing process is crucial. Insufficient washing will result in false positive results.
9. Duplicates are recommended for both standard and sample testing.

<b>Prepared By :</b> Ms. Gopika S. L. <b>Designation:</b> Laboratory Technician (P-5410)	<b>Signature:</b> 	<b>Issue Date :</b> 09.07.2021	<b>Page No 55</b>
<b>Verified By :</b> Dr. Dinoop K. P. <b>Designation:</b> Assistant Professor, Microbiology	<b>Signature:</b> 	<b>Revision No:</b>	<b>Copy no:</b> <b>Controlled</b>
<b>Issued By :</b> Dr. Kavita Raja <b>Designation:</b> Professor & Head, Microbiology	<b>Signature :</b> 	<b>ICMR Extramural Adhoc: P-5410</b>	

**Department of Microbiology**  
**Sree Chitra Tirunal Institute for Medical Sciences and Technology (SCTIMST)**

10. Never let the micro plate dry during the assay. A dried plate will inactivate active components on the plate.

11. Never reuse tips and tubes to avoid cross contamination.

12. Avoid using the reagents from different batches together.

**5.5.3i. Calibration procedures:** As per kit manufacturer's instructions

**5.5.3j. Steps of the procedure:** Same as 5.5.3c



**5.5.3k. Quality control procedures:** As per kit manufacturer's instructions

**5.5.3l. Interferences:**

1. The matrix components in the sample will affect the test results, which is why it needs to be diluted at least 1/2 with Sample Dilution Buffer before testing!
2. Icteric, hemolytic or hyperlipemic samples, or samples which are turbid or contain fibrin may yield imprecise results.

**5.5.3m. Principle and procedure for calculation of results:**

Results of a typical standard operation of a Presepsin ELISA Kit are listed below. This standard curve was generated at our lab for demonstration purpose only. Users shall obtain standard curve as per experiment by themselves. (N/A=not applicable)

<b>Prepared By :</b> Ms. Gopika S. L. <b>Designation:</b> Laboratory Technician (P-5410)	<b>Signature:</b> 	<b>Issue Date :</b> 09.07.2021	<b>Page No 56</b>
<b>Verified By :</b> Dr. Dinoop K. P. <b>Designation:</b> Assistant Professor, Microbiology	<b>Signature:</b> 	<b>Revision No:</b>	<b>Copy no: Controlled</b>
<b>Issued By :</b> Dr. Kavita Raja <b>Designation:</b> Professor & Head, Microbiology	<b>Signature :</b> 	<b>ICMR Extramural Adhoc: P-5410</b>	

**Department of Microbiology**  
**Sree Chitra Tirunal Institute for Medical Sciences and Technology (SCTIMST)**

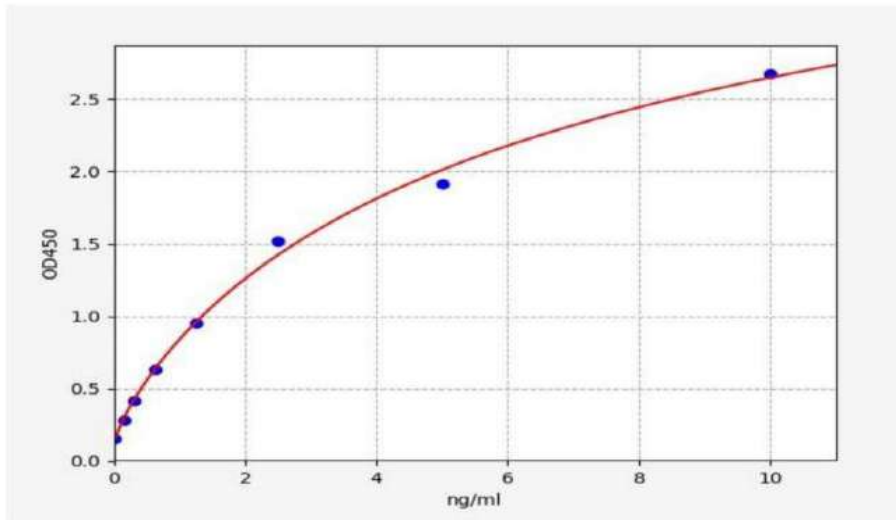

(Figure 4)

**5.5.3o Reportable interval of examination results: 156 -10000 pg/ml**

**5.5.3p. Instructions to determine quantitative results** (if not within measurement interval):

Serial doubling dilutions and multiplication of dilution factor to the value obtained.

**5.5.3q. Critical values/alerts:** >250 pg/ml

**5.5.3r. Laboratory clinical interpretation:**

- I. Patients without neurological injury: < 100 pg/ml
- II. Neurocritical care patients without systemic infection/meningitis:  $340.4 \pm 201.1$  pg/ml
- III. Patients with isolated meningitis:  $640.8 \pm 235.5$  pg/ml
- IV. Patients with systemic infection without NI-CNS:  $580.1 \pm 329.7$  pg/ml.

**5.5.3s. Potential sources of variation:** Nil



**5.5.3t. References:**

1. Nordic Biosite Human Presepsin ELISA Kit Manual<sup>[1]</sup>
2. Abudeev SA, Kiselev KV, Kruglyakov NM, Belousova KA, Lobanova IN, Parinov OV, et al. Cerebrospinal Fluid Presepsin As a Marker of Nosocomial Infections of the Central Nervous System: A Prospective Observational Study. Front Neurol 2018;9:58.

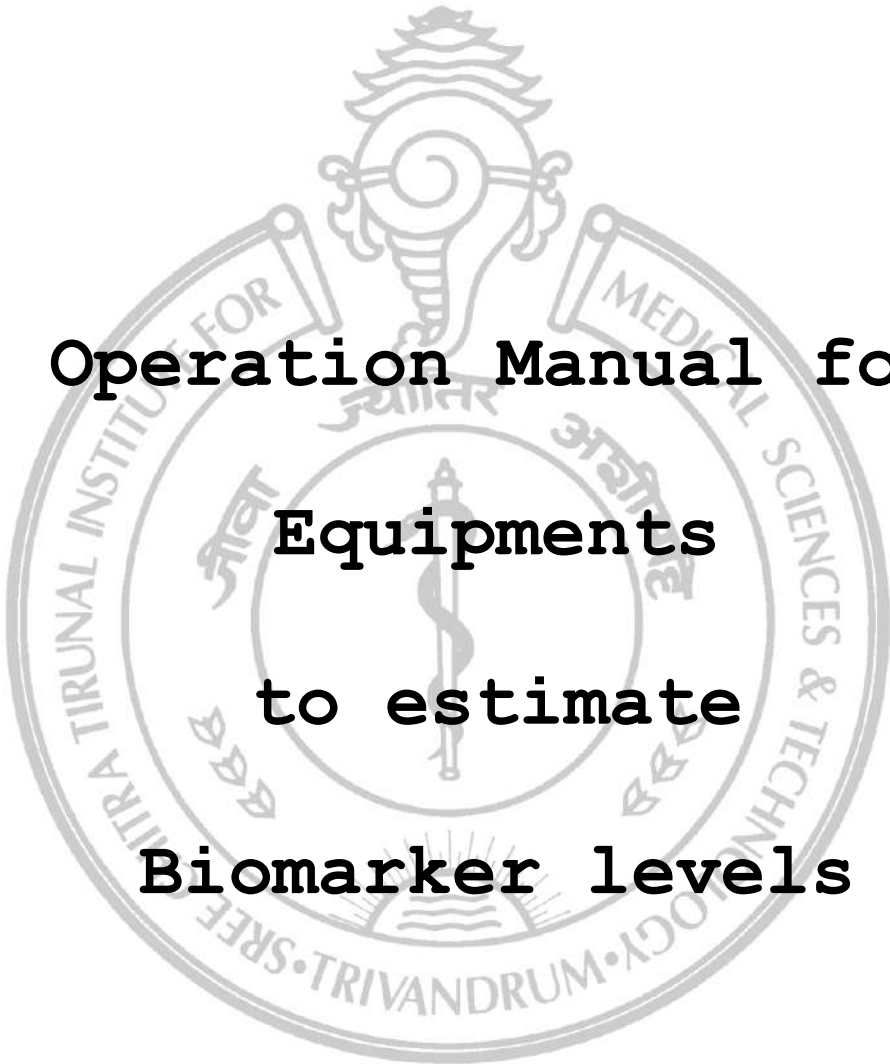
<b>Prepared By :</b> Ms. Gopika S. L. <b>Designation:</b> Laboratory Technician (P-5410)	<b>Signature:</b> 	<b>Issue Date :</b> 09.07.2021	<b>Page No 57</b>
<b>Verified By :</b> Dr. Dinoop K. P. <b>Designation:</b> Assistant Professor, Microbiology	<b>Signature:</b> 	<b>Revision No:</b>	<b>Copy no:</b> <b>Controlled</b>
<b>Issued By :</b> Dr. Kavita Raja <b>Designation:</b> Professor & Head, Microbiology	<b>Signature :</b> 	<b>ICMR Extramural Adhoc: P-5410</b>	



**Operation Manual for  
Equipments  
to estimate  
Biomarker levels**

<b>Prepared By :</b> Ms. Gopika S. L. <b>Designation:</b> Laboratory Technician (P-5410)	<b>Signature:</b> 	<b>Issue Date :</b> 09.07.2021	<b>Page No 58</b>
<b>Verified By :</b> Dr. Dinoop K. P. <b>Designation:</b> Assistant Professor, Microbiology	<b>Signature:</b> 	<b>Revision No:</b>	<b>Copy no: Controlled</b>
<b>Issued By :</b> Dr. Kavita Raja <b>Designation:</b> Professor & Head, Microbiology	<b>Signature :</b> 	<b>ICMR Extramural Adhoc: P-5410</b>	

## 1. QuantStudio 5 Real-Time PCR Instrument



### Introduction:

The QuantStudio™ 5 Real-Time PCR Instrument uses fluorescence-based polymerase chain reaction (PCR) reagents to perform:

- Quantitative detection of target nucleic acid sequences (targets).
- Qualitative detection of targets (endpoint analysis, genotyping, and presence/absence)

The instrument is configured with a 96-well 0.2-mL fixed block (6 color de-coupled). To run experiments using HID assays, the instrument must be integrated with the HID Real-Time PCR Analysis Software

### Parts of the instrument

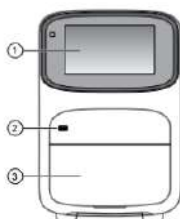

1. **Touchscreen** – Controls the instrument.

2. **USB port** – For connection to an external network drive or external data storage device.

<b>Prepared By :</b> Ms. Gopika S. L. <b>Designation:</b> Laboratory Technician (P-5410)	<b>Signature:</b> 	<b>Issue Date :</b> 09.07.2021	<b>Page No</b> 59
<b>Verified By :</b> Dr. Dinoop K. P. <b>Designation:</b> Assistant Professor, Microbiology	<b>Signature:</b> 	<b>Revision No:</b>	<b>Copy no:</b> <b>Controlled</b>
<b>Issued By :</b> Dr. Kavita Raja <b>Designation:</b> Professor & Head, Microbiology	<b>Signature :</b> 	<b>ICMR Extramural Adhoc: P-5410</b>	

**Department of Microbiology**  
**Sree Chitra Tirunal Institute for Medical Sciences and Technology (SCTIMST)**

3. **Instrument drawer** – Contains sample plate.

The instrument includes three additional USB ports on the back of the instrument.

Note:The instrument recognizes only one external storage device at a time for data transfer.









**Parts of the home screen**



1. Avatar and Instrument name
2. Eject instrument drawer icon
3. Help system icon
4. Status dial
5. Instrument profile name and instrument block type
6. **Settings** button
7. Access templates buttons (not applicable for HID-validated workflows)
8. Connectivity icons
9. **Sign In** (or **My Profile**) button

<b>Prepared By :</b> Ms. Gopika S. L. <b>Designation:</b> Laboratory Technician (P-5410)	<b>Signature:</b> 	<b>Issue Date :</b> 09.07.2021	<b>Page No</b> 60
<b>Verified By :</b> Dr. Dinoop K. P. <b>Designation:</b> Assistant Professor, Microbiology	<b>Signature:</b> 	<b>Revision No:</b>	<b>Copy no:</b> Controlled
<b>Issued By :</b> Dr. Kavita Raja <b>Designation:</b> Professor & Head, Microbiology	<b>Signature :</b> 	<b>ICMR Extramural Adhoc: P-5410</b>	

**Department of Microbiology**  
**Sree Chitra Tirunal Institute for Medical Sciences and Technology (SCTIMST)**



Element of the home screen	Function
Avatar and Instrument name	Set by the administrator to uniquely identify the instrument.
Eject instrument drawer icon	Touch  to open or close the instrument drawer.
Help icon	Touch  to launch the touchscreen Help system to access step-by-step instructions.
Status dial	<b>When the instrument is not in use</b> – Displays <b>Set up run</b> . <b>Note:</b> Instrument runs must be set up and started from the desktop software.
	<b>When the instrument is in use</b> – Displays the sample block temperature, the elapsed run time, and the run status. <b>Note:</b> Swipe the dial to the left or touch  to access real-time views of the run.
Instrument profile username and block type	Displays the username of a signed-in user and the instrument block type. <b>Note:</b> If no user is signed in, the instrument defaults to the <b>Guest</b> profile.
<b>Settings</b> button	Touch  <b>Settings</b> to configure, calibrate, or learn about the instrument.
Connectivity icons	<ul style="list-style-type: none"> <li> – The instrument is connected via a wired configuration.</li> <li> – A USB drive is plugged into the instrument.</li> </ul>
<b>Sign In</b> button ( <b>My Profile</b> button when a user is signed in)	<ul style="list-style-type: none"> <li>Touch  <b>Sign In</b> to sign into an instrument profile.</li> <li>Touch  <b>My Profile</b> to change instrument profile settings.</li> </ul>

### Instrument filters and supported dyes

**System dyes** The instrument uses a de-coupled six-color optical filter set that supports the dyes shown in the following table and figure. For more information about the spectral dye calibration kits available for the instrument, contact your HID Support Representative.

Peak filter	Color	Filter wavelength (nm) <sup>[1]</sup>		Factory-calibrated dyes	Example custom dyes
		Excitation	Emission		
x1-m1	Blue	470 ± 15	520 ± 15	FAM™, SYBR™ Green	SYTO9
x2-m2	Green	520 ± 10	558 ± 12	VIC™	JOE™, HEX™, TET™ [2]
x3-m3	Yellow	550 ± 10	587 ± 10	NED™, TAMRA™, ABY™ [3]	Cy®3
x4-m4	Orange	580 ± 10	623 ± 14	ROX™, JUN™ [3]	Texas Red™
x5-m5	Red	640 ± 10	682 ± 14	MUSTANG PURPLE™, Cy®5	LIZ™
x6-m6	Deep-Red	662 ± 10	711 ± 12	None [4]	Cy® 5.5

[1] The central wavelengths are the optimized wavelengths.

<b>Prepared By :</b> Ms. Gopika S. L. <b>Designation:</b> Laboratory Technician (P-5410)	<b>Signature:</b> 	<b>Issue Date :</b> 09.07.2021	<b>Page No</b> 61
<b>Verified By :</b> Dr. Dinoop K. P. <b>Designation:</b> Assistant Professor, Microbiology	<b>Signature:</b> 	<b>Revision No:</b>	<b>Copy no:</b> <b>Controlled</b>
<b>Issued By :</b> Dr. Kavita Raja <b>Designation:</b> Professor & Head, Microbiology	<b>Signature :</b> 	<b>ICMR Extramural Adhoc: P-5410</b>	

**Department of Microbiology**  
**Sree Chitra Tirunal Institute for Medical Sciences and Technology (SCTIMST)**

[2] The HEX™ and TET™ dyes from Thermo Fisher Scientific fall within the emission wavelength range of the system, therefore they can be added and adapted for use on the instrument.

[3] HID-validated workflows use versions of ABY™ and JUN™ dyes that are considered custom dyes.

[4] This filter set currently does not support any dyes supplied by Thermo Fisher Scientific.

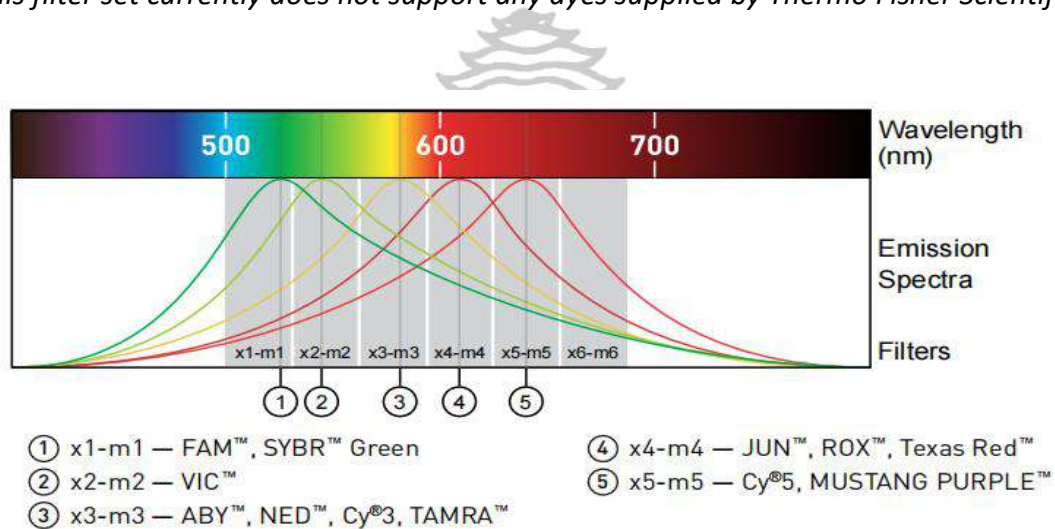

**Power on the instrument:**

1. Switch on the instrument by I/O button located in the right side of the instrument
2. Wait until the two LED's in front of the instrument are switched on.

To power on the instrument from a powered off state:

1. Touch anywhere on the touchscreen to determine if the instrument is in sleep mode. If the home screen displays, the instrument is already powered on.
2. If the home screen does not display, power on the instrument by pressing the switch on the rear panel.

<b>Prepared By :</b> Ms. Gopika S. L. <b>Designation:</b> Laboratory Technician (P-5410)	<b>Signature:</b> 	<b>Issue Date :</b> 09.07.2021	<b>Page No</b> 62
<b>Verified By :</b> Dr. Dinoop K. P. <b>Designation:</b> Assistant Professor, Microbiology	<b>Signature:</b> 	<b>Revision No:</b>	<b>Copy no:</b> Controlled
<b>Issued By :</b> Dr. Kavita Raja <b>Designation:</b> Professor & Head, Microbiology	<b>Signature :</b> 	<b>ICMR Extramural Adhoc: P-5410</b>	

**Department of Microbiology**  
**Sree Chitra Tirunal Institute for Medical Sciences and Technology (SCTIMST)**

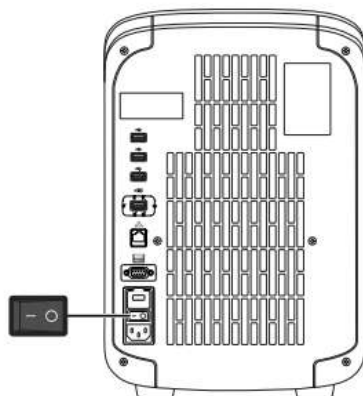

**Purpose of the Equipment: Human IL 17 A/ IL 1 Beta**

1. Switch on the instrument and the connected computer provided with "HID Realtime PCR analysis software v1.5.1"

2. Open QuantStudio™ Design and Analysis software v1.5.1 --> "Create new experiment"

3. "PROPERTIES" menu --> **Experiment properties**

- ◆ Name: IL 17A/1L 1Beta PLA
- ◆ Username: IL 17A/1L 1B PLA
- ◆ Instrument Type: QuantStudio™ 5 System
- ◆ Block Type: 96 well 0.2 mL Block
- ◆ Experiment Type: Standard Curve
- ◆ Chemistry: TagMan<sup>®</sup> Reagent
- ◆ Run Mode: Standard
- ◆ Select the appropriate properties as mentioned.

**4. Method Menu --> Experiment Method**

Volume: 50 mL

Cover: 105.0°C

<b>Prepared By :</b> Ms. Gopika S. L. <b>Designation:</b> Laboratory Technician (P-5410)	<b>Signature:</b> 	<b>Issue Date :</b> 09.07.2021	<b>Page No 63</b>
<b>Verified By :</b> Dr. Dinoop K. P. <b>Designation:</b> Assistant Professor, Microbiology	<b>Signature:</b> 	<b>Revision No:</b>	<b>Copy no:</b> <b>Controlled</b>
<b>Issued By :</b> Dr. Kavita Raja <b>Designation:</b> Professor & Head, Microbiology	<b>Signature :</b> 	<b>ICMR Extramural Adhoc: P-5410</b>	

**Department of Microbiology**  
**Sree Chitra Tirunal Institute for Medical Sciences and Technology (SCTIMST)**

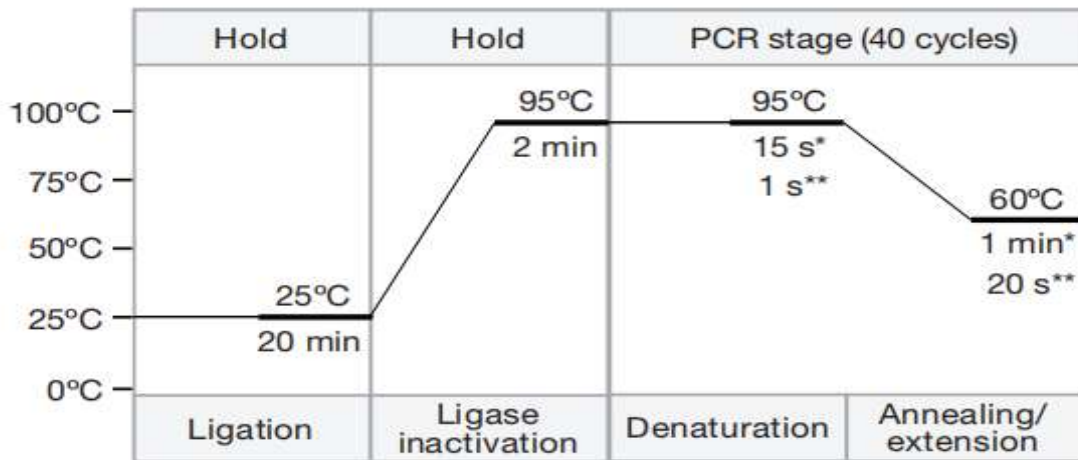

\* Standard protocol    \*\* Fast protocol

Set ramp rate to 2°C / sec

**5. Plate Menu --> Assign targets and samples --> Quick setup**

- ◆ **Well attributes**      Select the appropriate well  
                                  Sample: Unknown  
                                  Target: IL 17A/1L 1Beta
- ◆ **Plate attributes**  
     Passive Reference: ROX

**Load plate in the instrument**

1. Load the plate.
  - a. Touch to eject the instrument drawer.
  - b. Load the plate onto the plate adapter so that:
    - Well A1 of the plate is in the top-left corner of the plate adapter.
    - The barcode faces the front of the instrument.

<b>Prepared By :</b> Ms. Gopika S. L. <b>Designation:</b> Laboratory Technician (P-5410)	<b>Signature:</b> 	<b>Issue Date :</b> 09.07.2021	<b>Page No</b> 64
<b>Verified By :</b> Dr. Dinoop K. P. <b>Designation:</b> Assistant Professor, Microbiology	<b>Signature:</b> 	<b>Revision No:</b>	<b>Copy no:</b> Controlled
<b>Issued By :</b> Dr. Kavita Raja <b>Designation:</b> Professor & Head, Microbiology	<b>Signature :</b> 	<b>ICMR Extramural Adhoc: P-5410</b>	

**Department of Microbiology**  
**Sree Chitra Tirunal Institute for Medical Sciences and Technology (SCTIMST)**

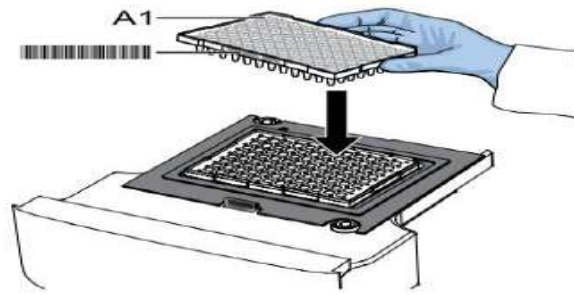

Note: Do not remove the black plate adapter before loading a plate or tube strips. If used, tube strips may fit loosely in the adapter, but the heated cover will apply the appropriate pressure to seat the tube strips securely in the adapter.

c. Touch  to close the instrument drawer.

**3. Run menu --> Run the experiment**

**Unload plate in the instrument**

When the run ends, unload the plate.

a. Touch  to eject the instrument drawer.

b. Remove the plate.



c. Touch  to close the instrument drawer.

**CAUTION! PHYSICAL INJURY HAZARD.** During instrument operation, the plate temperature can reach 100°C. Allow it to cool to room temperature before handling.

Note: If the instrument does not eject the plate, contact Support

**Calibration:**

Set the calibration frequency for the instrument: Touch **Settings > Maintenance and Service > Calibrations > History and Reminders > Edit > Exp interval field.**

<b>Prepared By :</b> Ms. Gopika S. L. <b>Designation:</b> Laboratory Technician (P-5410)	<b>Signature:</b> 	<b>Issue Date :</b> 09.07.2021	<b>Page No 65</b>
<b>Verified By :</b> Dr. Dinoop K. P. <b>Designation:</b> Assistant Professor, Microbiology	<b>Signature:</b> 	<b>Revision No:</b>	<b>Copy no: Controlled</b>
<b>Issued By :</b> Dr. Kavita Raja <b>Designation:</b> Professor & Head, Microbiology	<b>Signature :</b> 	<b>ICMR Extramural Adhoc: P-5410</b>	



**Department of Microbiology**  
**Sree Chitra Tirunal Institute for Medical Sciences and Technology (SCTIMST)**

Calibration	Recommended frequency
ROI/Uniformity	<ul style="list-style-type: none"> <li>• Every two years (recommended)</li> <li>• Always perform new background and dye calibrations after an ROI/uniformity calibration.</li> </ul> <p><b>Note:</b> Performing an ROI/uniformity calibration invalidates all other calibrations.</p>
Background	<ul style="list-style-type: none"> <li>• Every two years (recommended)</li> <li>• Background calibration can also be performed, as needed:               <ul style="list-style-type: none"> <li>- To check for contamination (depends on usage and laboratory conditions).</li> <li>- To obtain the most accurate data for the removal of background fluorescence.</li> </ul> </li> </ul> <p><b>Note:</b> Performing a background calibration does <i>not</i> invalidate any other calibration.</p>
Dye ( <i>system and custom dyes, including ABY™ and JUN™ dyes</i> )	<ul style="list-style-type: none"> <li>• Every two years (recommended)</li> <li>• During a dye calibration, only the dyes on the given spectral calibration plate are calibrated.</li> </ul> <p><b>Note:</b> Performing a dye calibration for a given dye plate does <i>not</i> invalidate any other calibration.</p>
RNase P instrument verification	<ul style="list-style-type: none"> <li>• After performing instrument calibrations</li> <li>• As needed to confirm instrument performance</li> </ul>

**Maintenance:**

Backup or restore the instrument

1. In the home screen:
2. Touch **Settings > Maintenance and Service > Backup/Restore.**
3. Identify the contaminated wells of the sample block.
4. Prepare the instrument and access the sample block:
  - a. Power off and unplug the instrument, then allow it to cool for 15 minutes.
  - b. Pull the instrument drawer forward to expose the sample block.
5. Rinse the contaminated wells with deionized water

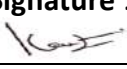
<b>Prepared By :</b> Ms. Gopika S. L. <b>Designation:</b> Laboratory Technician (P-5410)	<b>Signature:</b> 	<b>Issue Date :</b> 09.07.2021	<b>Page No</b> 66
<b>Verified By :</b> Dr. Dinoop K. P. <b>Designation:</b> Assistant Professor, Microbiology	<b>Signature:</b> 	<b>Revision No:</b>	<b>Copy no:</b> <b>Controlled</b>
<b>Issued By :</b> Dr. Kavita Raja <b>Designation:</b> Professor & Head, Microbiology	<b>Signature :</b> 	<b>ICMR Extramural Adhoc: P-5410</b>	



**Department of Microbiology**  
**Sree Chitra Tirunal Institute for Medical Sciences and Technology (SCTIMST)**



6. Close the drawer and test the sample block for contamination:
  - a. Push the instrument drawer back in to the instrument.
  - b. Plug in, then power on the instrument.
  - c. Perform a background calibration to confirm that you have eliminated the contamination.
7. If the contamination remains:
  - a. Repeat step 2 – step 3.
  - b. Clean the contaminated wells using a 95% ethanol solution.
  - c. Repeat step 3 – step 4 to rinse the sample block with deionized water and to confirm that you have eliminated the contamination.
8. If the contamination still remains:
  - a. Repeat step 2 – step 3.
  - b. Clean the contaminated wells using a 10% bleach solution
  - c. Repeat step 3 – step 4 to rinse the sample block with deionized water and to confirm that you have eliminated the contamination.
9. If the contamination continues to remain, contact Support.

**References:**

*QuantStudio™ 5 Real-Time PCR Instrument User Guide*



<b>Prepared By :</b> Ms. Gopika S. L. <b>Designation:</b> Laboratory Technician (P-5410)	<b>Signature:</b> 	<b>Issue Date :</b> 09.07.2021	<b>Page No 67</b>
<b>Verified By :</b> Dr. Dinoop K. P. <b>Designation:</b> Assistant Professor, Microbiology	<b>Signature:</b> 	<b>Revision No:</b>	<b>Copy no:</b> <b>Controlled</b>
<b>Issued By :</b> Dr. Kavita Raja <b>Designation:</b> Professor & Head, Microbiology	<b>Signature :</b> 	<b>ICMR Extramural Adhoc: P-5410</b>	

## 2. B·R·A H·M·S KRYPTOR compact PLUS



### Intended Use

B.R.A.H.M.S KRYPTOR compact PLUS is a fully auto-mated system for in vitro diagnostic. It is used for measurement of patient samples in random access mode routinely. B.R.A.H.M.S KRYPTOR compact PLUS is a closed system and can only operate utilizing special reagents offered by B·R·A·H·M·S GmbH.

<b>Prepared By :</b> Ms. Gopika S. L. <b>Designation:</b> Laboratory Technician (P-5410)	<b>Signature:</b> 	<b>Issue Date :</b> 09.07.2021	<b>Page No 68</b>
<b>Verified By :</b> Dr. Dinoop K. P. <b>Designation:</b> Assistant Professor, Microbiology	<b>Signature:</b> 	<b>Revision No:</b>	<b>Copy no: Controlled</b>
<b>Issued By :</b> Dr. Kavita Raja <b>Designation:</b> Professor & Head, Microbiology	<b>Signature :</b> 	<b>ICMR Extramural Adhoc: P-5410</b>	

**Department of Microbiology**  
**Sree Chitra Tirunal Institute for Medical Sciences and Technology (SCTIMST)**

The system is based on **TRACE technology (Time-Resolved Amplified Cryptate Emission)**. The system and the reagents are under continuous development by B·R·A·H·M·S GmbH.

**Introduction:**

**TRACE – the unique measuring principle of B.R.A.H.M.S KRYPTOR compact PLUS**

The measurement principle of B.R.A.H.M.S KRYPTOR/ KRYPTOR compact is based on **TRACE technology**, which measures the signal that is emitted from an immuno complex with time delay.



The basis of the TRACE technology is non-radiative energy transfer from a donor (a cage-like structure with a europium ion in the center [cryptate]) to an acceptor, which is part of a chemically modified, light-collecting algal protein (XL 665). The proximity of donor (cryptate) and acceptor (XL 665) when they are part of an immuno complex and the spectral overlap between donor emission and acceptor absorption spectra on the one hand, intensify the fluorescent signal of the cryptate and on the other hand they extend the life span of the acceptor signal, permitting the measurement of temporally delayed fluorescence.

**Precise measurement of analyte concentration**

When the sample is excited with a nitrogen laser at 337 nm, the donor (cryptate) emits a long-life fluorescent signal in the milli-second range at 620 nm, while the acceptor (XL 665) generates a short-life signal in the nanosecond-range at 665 nm. When the two components are bound in an immuno complex, both the signal amplification and the prolonged life span of the acceptor signal occur at 665 nm, so that it can be measured over  $\mu$ -seconds. This long-life signal is proportional to the concentration of the analyte to be measured.

**Reliable prevention of interference**

Non-specific signals, e.g. the signals of the short-life and unbound acceptor XL 665 and the medium specific interference signals conditional upon the natural fluorescence of the sample, are eliminated by temporal delay of the fluorescence measurement. The signal generated by the cryptate at 620 nm serves as an internal reference and is measured simultaneously with the long-life acceptor signal at 665 nm which is the specific signal. Interfering influences, e.g. from turbid sera, are automatically corrected by means of the internally calculated ratio of the intensities at these wavelengths.

<b>Prepared By :</b> Ms. Gopika S. L. <b>Designation:</b> Laboratory Technician (P-5410)	<b>Signature:</b> 	<b>Issue Date :</b> 09.07.2021	<b>Page No</b> 69
<b>Verified By :</b> Dr. Dinoop K. P. <b>Designation:</b> Assistant Professor, Microbiology	<b>Signature:</b> 	<b>Revision No:</b>	<b>Copy no:</b> <b>Controlled</b>
<b>Issued By :</b> Dr. Kavita Raja <b>Designation:</b> Professor & Head, Microbiology	<b>Signature :</b> 	<b>ICMR Extramural Adhoc: P-5410</b>	

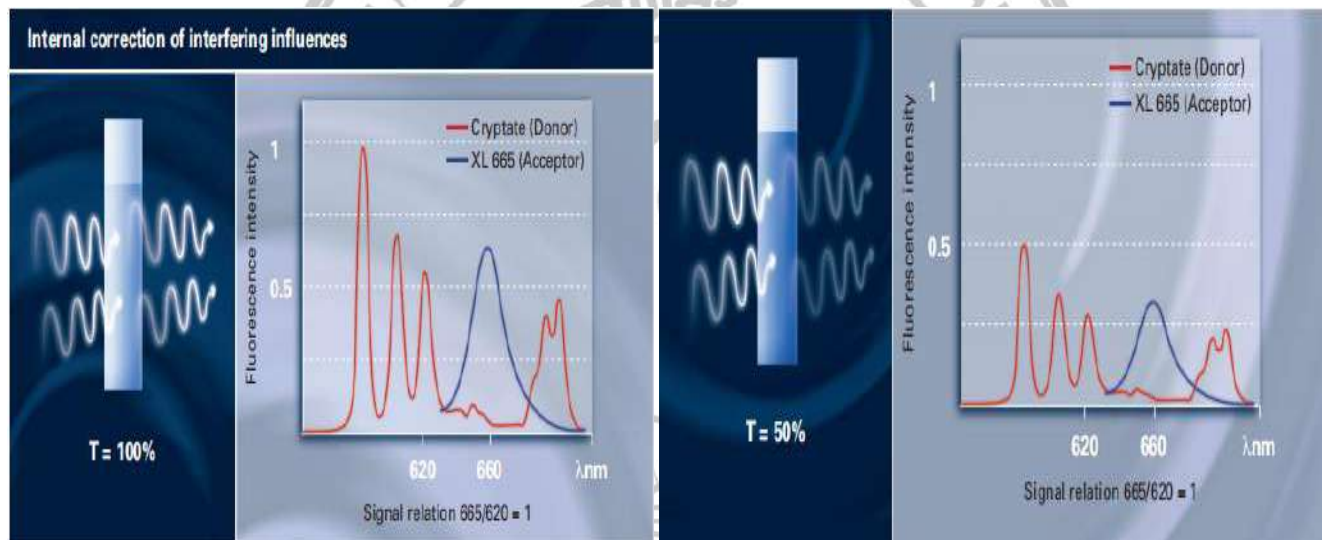
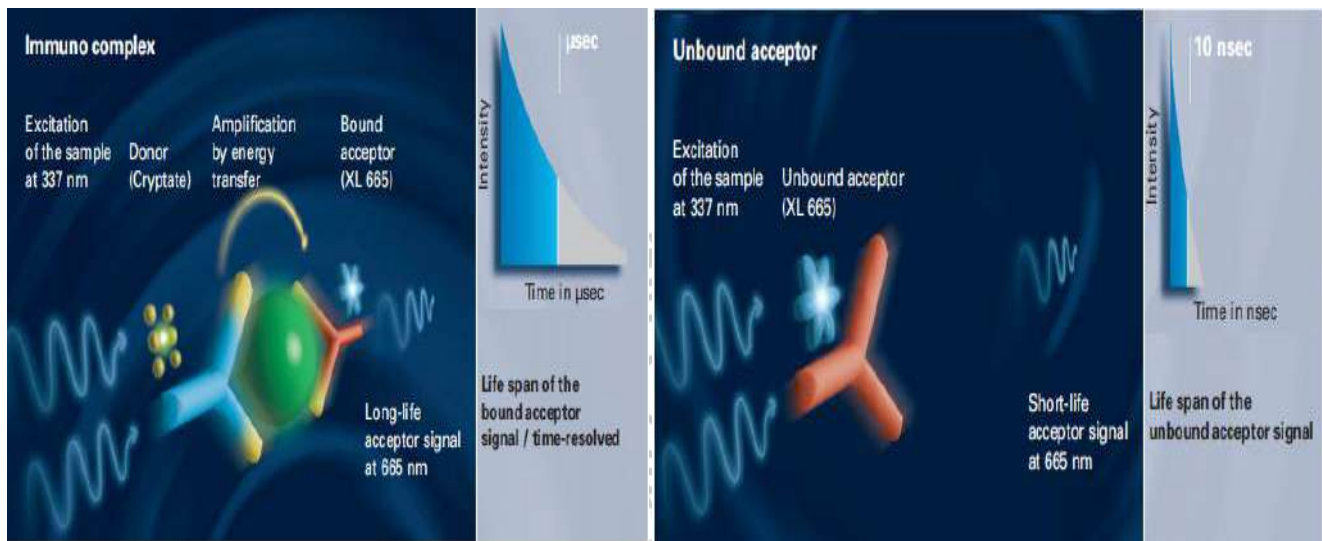

**Instrument Components**

This instrument has two parts: **pipetting module and reading module.**

**Pipetting Module**

This part comprised with

1. Pipetting unit
2. Fluidic system
3. Carrousel .

<b>Prepared By :</b> Ms. Gopika S. L. <b>Designation:</b> Laboratory Technician (P-5410)	<b>Signature:</b> 	<b>Issue Date :</b> 09.07.2021	<b>Page No</b> 70
<b>Verified By :</b> Dr. Dinoop K. P. <b>Designation:</b> Assistant Professor, Microbiology	<b>Signature:</b> 	<b>Revision No:</b>	<b>Copy no:</b> <b>Controlled</b>
<b>Issued By :</b> Dr. Kavita Raja <b>Designation:</b> Professor & Head, Microbiology	<b>Signature :</b> 	<b>ICMR Extramural Adhoc: P-5410</b>	

**Department of Microbiology**  
**Sree Chitra Tirunal Institute for Medical Sciences and Technology (SCTIMST)**



**1. Pipetting unit**



The pipetting unit consists of a heated tip sample probe and a wash station. The heated tip uses a capacitive liquid level detection system to aspirate all components required to perform the biological analysis. This includes the sample, diluent and reagents. . After aspirating the sample and reagent components into the tip, the tip is heated to reaction temperature and acts as a pre-reaction incubator. This ensures that the fluids are at reaction temperature before dispensing into the reaction area. At the end of dispense, the tip is washed to avoid carry-over contamination between samples.

**Caution**, any fluidic hood opening stops tip motion.

**2. Fluidic system**

The fluidic system includes 3 bottles of 5 liters. One for the PBS wash liquid (BUFFER; order code for the buffer: B.R.A.H.M.S KRYPTOR BUFFER) used to wash the tubing system after pipetting. A second bottle with distilled or demineralized water used as liquid system (DISTILLED WATER) by priming before pipetting and to keep the tubing line in water during instrument stand by or switch off. . third bottle is used to collect liquid waste (WASTE). Only the waste bottle contains a float sensor on the cap to manage the liquid level and a mechanical sensor for bottle presence.



<b>Prepared By :</b> Ms. Gopika S. L. <b>Designation:</b> Laboratory Technician (P-5410)	<b>Signature:</b> 	<b>Issue Date :</b> 09.07.2021	<b>Page No</b> 71
<b>Verified By :</b> Dr. Dinoop K. P. <b>Designation:</b> Assistant Professor, Microbiology	<b>Signature:</b> 	<b>Revision No:</b>	<b>Copy no:</b> <b>Controlled</b>
<b>Issued By :</b> Dr. Kavita Raja <b>Designation:</b> Professor & Head, Microbiology	<b>Signature :</b> 	<b>ICMR Extramural Adhoc: P-5410</b>	

**Department of Microbiology**  
**Sree Chitra Tirunal Institute for Medical Sciences and Technology (SCTIMST)**

Levels of buffer and distilled water are managed by float switches within the main body of the instrument. When the bottle becomes red on the VDU screen, it is possible to refill the bottles without interruption to the current run. There is no fluid sensor on these two bottles.

Distilled or demineralized water tank with floating switch

PBS Tank with floating switch

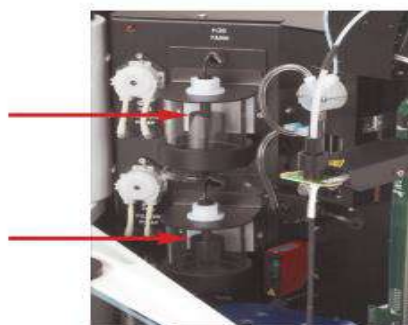

### 3. Carousel

The carousel is divided into 5 positions. Positions 1, 2 and 3 are hybrid locations which allow to put reagent or sample trays. Positions 4 and 5 are dedicated only for sample trays. When the hood is open, it is possible to turn the carousel by hand to simplify access to each position.



### Reagent's tray

This accessory contains up to 4 reagent kits. The cooling system (2-8 °C) is operational only when the tray is installed on the carousel and the instrument is turned on. An infrared system is used to detect reagent segments during movement of the carousel. Barcoded identification of reagent kits is

<b>Prepared By :</b> Ms. Gopika S. L. <b>Designation:</b> Laboratory Technician (P-5410)	<b>Signature:</b> 	<b>Issue Date :</b> 09.07.2021	<b>Page No</b> 72
<b>Verified By :</b> Dr. Dinoop K. P. <b>Designation:</b> Assistant Professor, Microbiology	<b>Signature:</b> 	<b>Revision No:</b>	<b>Copy no:</b> <b>Controlled</b>
<b>Issued By :</b> Dr. Kavita Raja <b>Designation:</b> Professor & Head, Microbiology	<b>Signature :</b> 	<b>ICMR Extramural Adhoc: P-5410</b>	

**Department of Microbiology**  
**Sree Chitra Tirunal Institute for Medical Sciences and Technology (SCTIMST)**



automatically scanned when the carousel rotates. Caution: Put the kit in right order, barcode must be visible within the Perspex window. Inventory for all reagent kits and reagent segment temperature is fully managed by the software with use of colour codes.



**Tray for samples, dilution plates and SOLUTIONS 1-4**

This tray has space for 16 sample tubes which can be any combination of primary or secondary tubes at a height between 60 mm and 120 mm and a diameter between 11 mm and 17 mm. Calibrators, controls and micro-cups in a specific metallic adaptor can also be installed. This tray also has space to install SOLUTIONS 1-4 or dilution plates. Sample trays are detected on board by barcode identification placed on the top and the middle of the segment.



<b>Prepared By :</b> Ms. Gopika S. L. <b>Designation:</b> Laboratory Technician (P-5410)	<b>Signature:</b> 	<b>Issue Date :</b> 09.07.2021	<b>Page No</b> 73
<b>Verified By :</b> Dr. Dinoop K. P. <b>Designation:</b> Assistant Professor, Microbiology	<b>Signature:</b> 	<b>Revision No:</b>	<b>Copy no:</b> <b>Controlled</b>
<b>Issued By :</b> Dr. Kavita Raja <b>Designation:</b> Professor & Head, Microbiology	<b>Signature :</b> 	<b>ICMR Extramural Adhoc: P-5410</b>	

**Department of Microbiology**  
**Sree Chitra Tirunal Institute for Medical Sciences and Technology (SCTIMST)**

**SOLUTIONS 1, 2, 3 and 4 (order code B.R.H.M.S KRYPTOR compact SOLUTION 1-4)**

The SOLUTIONS 1 and 2 are used for reconstitution of freeze dried reagents. The SOLUTIONS 3 and 4 are needed for different washing steps between pipetting reagents and samples. Their use depends on the analytes. Do not top-up the bottles. Each solution bottle is managed on the instrument by the software through a barcode placed on the top of the bottle. SOLUTIONS 1 and 2 are mandatory to launch reconstitution of reagent kits. SOLUTIONS 3 and 4 are mandatory to launch pipetting sequence for samples.

**DILUTION PLATES (order code B.R.. .H.M.S KRYPTOR compact DILCUP)**

The dilution plate, which consists of 24 wells, is used by the system to reduce a high concentration or make a recovery test by using a diluent or a specific reagent. A barcode placed on the convex side of the plate, allows the software to monitor the availability of wells and lifetime on board the instrument.



**4. Reading Module**

Power on or off of the complete instrument is done with the button O/I placed on right side of reading module. This module consists of the reaction area and optical reading system to measure the signal emitted by the immuno complex. The reaction plate contains 96 wells (order code B.R.A.H.M.S KRYPTOR compact REACT) and its life onboard the instrument is monitored by the software through a barcode placed on each reaction plate and transparent damper closing. The reaction plate is heated at  $37\text{ }^{\circ}\text{C} \pm 0.5\text{ }^{\circ}\text{C}$ .

**5. Handheld barcode reader A**

All relevant information concerning calibrators, controls, reagent lots and reaction plate barcodes are registered on B.R.A.H.M.S KRYPTOR compact PLUS by the barcode reader as well as reaction plate barcode.



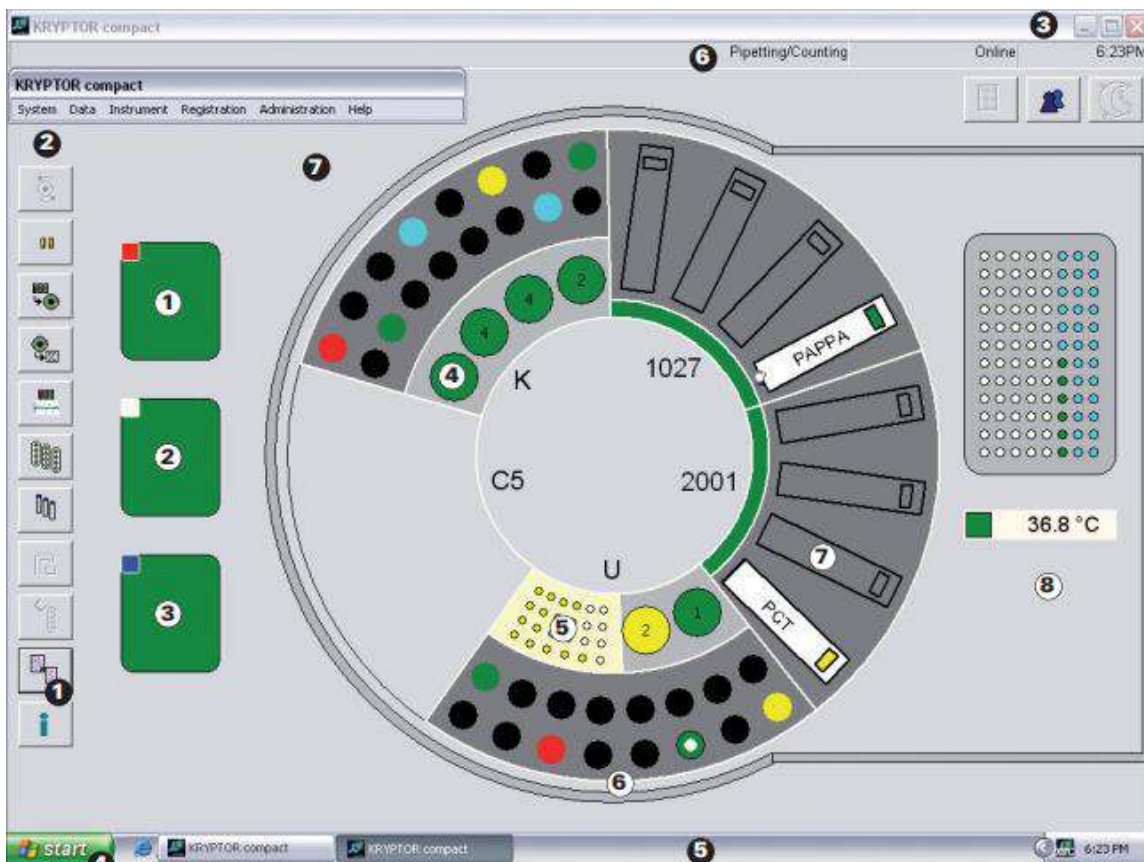

<b>Prepared By :</b> Ms. Gopika S. L. <b>Designation:</b> Laboratory Technician (P-5410)	<b>Signature:</b> 	<b>Issue Date :</b> 09.07.2021	<b>Page No</b> 74
<b>Verified By :</b> Dr. Dinoop K. P. <b>Designation:</b> Assistant Professor, Microbiology	<b>Signature:</b> 	<b>Revision No:</b>	<b>Copy no:</b> <b>Controlled</b>
<b>Issued By :</b> Dr. Kavita Raja <b>Designation:</b> Professor & Head, Microbiology	<b>Signature :</b> 	<b>ICMR Extramural Adhoc: P-5410</b>	

Description of the System Status Window



- |  |   |
|--|---|
| <ul style="list-style-type: none"> <li>❶ ACCESS TO MAIN MENUS</li> <li>❷ B-R-A-H-M-S KRYPTOR compact PLUS TOOL BAR</li> <li>❸ WINDOWS COMMAND BAR</li> <li>❹ WINDOWS START BUTTON</li> <li>❺ WINDOWS TASK BAR</li> <li>❻ STATUS BAR</li> </ul> | <ul style="list-style-type: none"> <li>❶ Waste</li> <li>❷ Distilled or demineralized water: Liquid system</li> <li>❸ Buffer PBS: Phosphate Buffer Saline: Wash liquid</li> <li>❹ B-R-A-H-M-S KRYPTOR compact Wash Solutions</li> <li>❺ Dilution plates</li> <li>❻ Sample tray</li> <li>❼ Reagents tray</li> <li>❽ Reaction plate</li> </ul> |
|--|---|
- B-R-A-H-M-S KRYPTOR compact PLUS  
WORK SURFACE

<b>Prepared By :</b> Ms. Gopika S. L. <b>Designation:</b> Laboratory Technician (P-5410)	<b>Signature:</b> 	<b>Issue Date :</b> 09.07.2021	<b>Page No</b> 75
<b>Verified By :</b> Dr. Dinoop K. P. <b>Designation:</b> Assistant Professor, Microbiology	<b>Signature:</b> 	<b>Revision No:</b>	<b>Copy no:</b> Controlled
<b>Issued By :</b> Dr. Kavita Raja <b>Designation:</b> Professor & Head, Microbiology	<b>Signature :</b> 	<b>ICMR Extramural Adhoc: P-5410</b>	

**Department of Microbiology**  
**Sree Chitra Tirunal Institute for Medical Sciences and Technology (SCTIMST)**

**Work Surface Colour Codes**

**Sample Carousel**

At the end of carousel scan, all samples with a barcode and tests in the worklist will be shown in green, blue, yellow or red. If the system is connected to LIS, there are different colours for the sample status (see Administration Menu/ LIS interface in B.R.A.H.M.S KRYPTOR compact PLUS Manual). An information window is available by clicking with the left button of the mouse on a selected sample. In case of sample tubes without barcodes, it is possible to identify a location in the sample tray by manual entry through the **Carousel Status** window, or the worklist.

Double click on sample tube to open **Carousel Status** window.

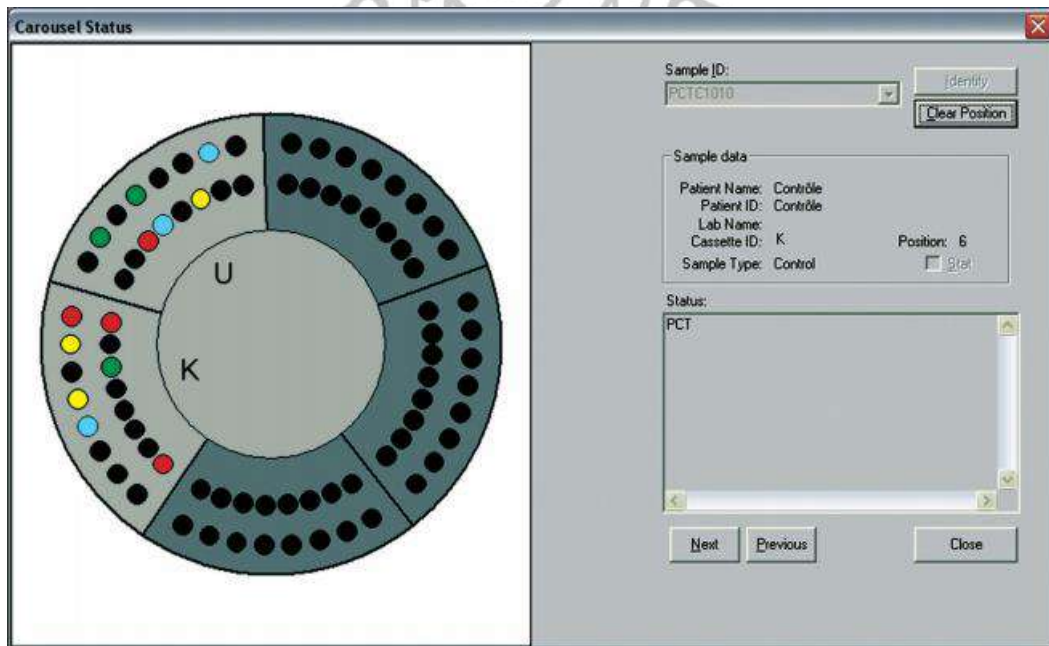





COLOUR	EXPLANATION
●	<b>Black:</b> no sample present
●	<b>Dark green:</b> the sample is ready to be tested
○	<b>Dark green with a white point:</b> sample during pipetting process
●	<b>Dark green with a red circle:</b> STAT sample
●	<b>Blue:</b> sample to be removed (all the tests of this sample have processed successfully including the out of range detection)
●	<b>Yellow:</b> sample with barcode without test in worklist or presence on carousel of same ID on different sample tube
●	<b>Red:</b> problem with sample processing (e.g. reagent related, consumables related; clot, insufficient sample volume)
○	<b>Red with a white point:</b> sample during pipetting process with at least one test with problem

<b>Prepared By :</b> Ms. Gopika S. L. <b>Designation:</b> Laboratory Technician (P-5410)	<b>Signature:</b> 	<b>Issue Date :</b> 09.07.2021	<b>Page No</b> 76
<b>Verified By :</b> Dr. Dinoop K. P. <b>Designation:</b> Assistant Professor, Microbiology	<b>Signature:</b> 	<b>Revision No:</b>	<b>Copy no:</b> Controlled
<b>Issued By :</b> Dr. Kavita Raja <b>Designation:</b> Professor & Head, Microbiology	<b>Signature :</b> 	<b>ICMR Extramural Adhoc: P-5410</b>	





**Department of Microbiology**  
**Sree Chitra Tirunal Institute for Medical Sciences and Technology (SCTIMST)**



**Reagent area**

Each reagent cassette has its own identification. An information area appears by clicking (left button of the mouse) on reagent tray screen image, this shows cassette ID and temperature in degrees of the kit. A **colour code** on the circle portion exists as a quick visual check of the right temperature in the reagent area or a reagent cassette's fan fault

COLOUR	TEMPERATURE BAR ON THE REAGENT AREA
	<b>Green:</b> 2.0...8.0 °C
	<b>Blue:</b> < 2.0 °C
	<b>Red:</b> > 8.0 °C or communication failed
	<b>Yellow:</b> one or more reagent cassette's fan is out of order

All reagent kits detected by barcode are shown on screen in the appropriate reagent cassette more detailed information Window is available by clicking (left button of the mouse) on a reagent kit. The colour of the background indicates the availability of the kits and the colour of the rectangle indicates the number of remaining tests.

COLOUR	EXPLANATION
	<b>White background:</b> Kit OK (calibration and reconstitution OK) <b>Red rectangle:</b> Number of tests remaining: ≤ 5
	<b>White background:</b> Kit OK (calibration and reconstitution OK) <b>Yellow rectangle:</b> Number of tests remaining: > 5 – ≤ 10
	<b>White background:</b> Kit OK (calibration and reconstitution OK) <b>Green rectangle:</b> Number of tests remaining: > 10
	<b>Yellow background:</b> Kit or calibration expires tomorrow <b>Green rectangle:</b> Number of tests remaining: > 10
	<b>Red background:</b> Kit to reconstitute, to calibrate or expired kit or no test remaining

<b>Prepared By :</b> Ms. Gopika S. L. <b>Designation:</b> Laboratory Technician (P-5410)	<b>Signature:</b> 	<b>Issue Date :</b> 09.07.2021	<b>Page No 77</b>
<b>Verified By :</b> Dr. Dinoop K. P. <b>Designation:</b> Assistant Professor, Microbiology	<b>Signature:</b> 	<b>Revision No:</b>	<b>Copy no:</b> <b>Controlled</b>
<b>Issued By :</b> Dr. Kavita Raja <b>Designation:</b> Professor & Head, Microbiology	<b>Signature :</b> 	<b>ICMR Extramural Adhoc: P-5410</b>	

**Department of Microbiology**  
**Sree Chitra Tirunal Institute for Medical Sciences and Technology (SCTIMST)**

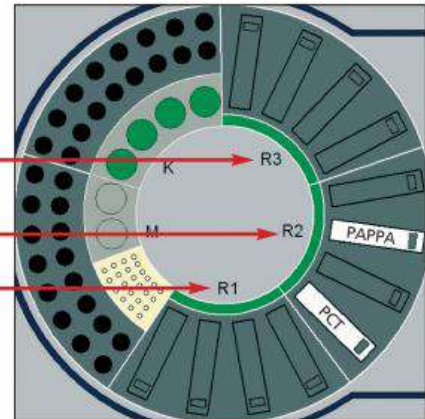
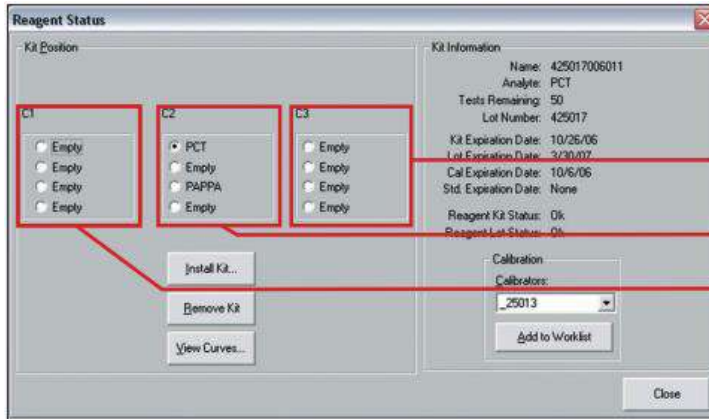

Double clicking anywhere in the reagent area opens the **Reagent Status** window. This window enables you to display information about each reagent kit installed in the reagent area of the instrument and to request calibration for each reagent kit.

**Reaction Area**

Each reaction plate is barcode labelled to allow the loading of the plate. The reaction plate has to be loaded to activate its preheating and to allow the dispensing of samples. Click on the plate to view the exact number of tests dispensed and completed. When the reaction plate is full, there is no automatic unloading, it is necessary to request by clicking on reaction plate. reaction plate not used but unloaded could be loaded again during 2 hours after its first loading. There is no automatic shutdown (machine remains in ready stage). As long as the reaction plate is on board, it is ready to be used, until 7 days are passed or plate is full. After 7 days, the plate is automatically unloaded at the next end of day (first ready or initialized stage after midnight). Time validity status of reaction plate is available when clicking with the left mouse button on the reaction plate on the screen. If there is an "xy position error", the plate is automatically unloaded, and cannot be used any more.

COLOUR	EXPLANATION
	<b>Green:</b> Proportion of tests running and not completed
	<b>Blue:</b> Proportion of tests completed
	<b>Green:</b> 36.2...38.0 °C
	<b>Blue:</b> < 36.2 °C
	<b>Red:</b> > 38.0 °C

<b>Prepared By :</b> Ms. Gopika S. L. <b>Designation:</b> Laboratory Technician (P-5410)	<b>Signature:</b> 	<b>Issue Date :</b> 09.07.2021	<b>Page No</b> 78
<b>Verified By :</b> Dr. Dinoop K. P. <b>Designation:</b> Assistant Professor, Microbiology	<b>Signature:</b> 	<b>Revision No:</b>	<b>Copy no:</b> <b>Controlled</b>
<b>Issued By :</b> Dr. Kavita Raja <b>Designation:</b> Professor & Head, Microbiology	<b>Signature :</b> 	<b>ICMR Extramural Adhoc: P-5410</b>	



**Department of Microbiology**  
**Sree Chitra Tirunal Institute for Medical Sciences and Technology (SCTIMST)**

Pipetting sequence does not start if the reaction area temperature is below to 35.7 °C or over 38.5 °C.

**Dilution Plate**



Each dilution plate is barcode labelled to manage the wells used and the shelf life on board (365 days).

Check dilution plate cleanness during daily maintenance.

COLOUR	EXPLANATION
	White well = available well / coloured well = used well
	<b>Green:</b> More than 10 wells available
	<b>Yellow:</b> From 5 to 10 wells available
	<b>Red:</b> Less than 5 wells available or expired



**B.R.A.H.M.S KRYPTOR compact SOLUTIONS 1 to 4**



For SOLUTIONS 1 and 2, the dead volume has been defined to finish a reconstitution started even if red level is detected; it is normal to have around 12 mL in SOLUTION 1 and approximately 8 mL in SOLUTION 2 when red status appears on the interface screen. For SOLUTIONS 3 and 4 the dead volume is around 4 mL, defined to finish wash step.

COLOUR	EXPLANATION
	<b>Green:</b> OK
	<b>Yellow:</b> Take care to change the bottle soon / solution expires tomorrow
	<b>Red:</b> Bottle to be replaced = dead volume reached or solution expired

**Fluidic System**

An intermediate tank system enables you to refill B.R.A.H.M.S KRYPTOR BUFFER or distilled/demineralized water bottle when red status is detected without stopping the current run by use of dead volume in intermediate tank system. If the dead volume is used then waste red level is detected and the instrument stops at the end of current run or prime. . prime is mandatory after refilling a bottle.

COLOUR	EXPLANATION
	<b>Green:</b> OK
	<b>Red:</b> Waste bottle full (void), buffer or water bottle empty (filling), intermediate waste collector full (Call Hot Line)

<b>Prepared By :</b> Ms. Gopika S. L. <b>Designation:</b> Laboratory Technician (P-5410)	<b>Signature:</b> 	<b>Issue Date :</b> 09.07.2021	<b>Page No</b> 79
<b>Verified By :</b> Dr. Dinoop K. P. <b>Designation:</b> Assistant Professor, Microbiology	<b>Signature:</b> 	<b>Revision No:</b>	<b>Copy no:</b> Controlled
<b>Issued By :</b> Dr. Kavita Raja <b>Designation:</b> Professor & Head, Microbiology	<b>Signature :</b> 	<b>ICMR Extramural Adhoc: P-5410</b>	



**Department of Microbiology**  
**Sree Chitra Tirunal Institute for Medical Sciences and Technology (SCTIMST)**

**Routine Work**

**Start-up**



Fill the appropriate bottles with distilled or demineralized water and buffer PBS, empty the waste bottle. Ensure B.R.A.H.M.S KRYPTOR compact SOLUTIONS 1 to 4 are on board. If B.R.H.M.S KRYPTOR compact SOLUTIONS 1 to 4 are closed, open the caps. **Put caps into specific locations and inscribe the caps with number of solution.** Check the fluidic and carousel hoods are closed.

**After a power off**

- Check if carousel hood is closed.
- Switch on the instrument with O/I (ON/OFF) button found on right side of the instrument.
- Switch on the XPC, monitor, printer.
- Click on Windows Start button and choose  icon to launch the B.R.H.M.S KRYPTOR compact software. 2 programs will be started:
  - 1) XPC program is the user interface.
  - 2) Check if XIPC program is active by icon presence on clock bar 

**After a Shutdown start here**

- Check if carousel hood is closed.
- Click on 
- Select **Name** and **Password** (e.g. user: : dmin and password: : dmin) in the **System LogOn** window.
- An automatic scan is launched after motor initialization. System is ready to use at the end of scan.
- An automatic scan is done every two minutes when carousel hood is closed to manage reagent tray temperature.
- Do **maintenances** as requested.
- Place a new reaction plate, close the transparent damper and load it by scanning the barcode.
- Request carousel hood opening by pressing on the blue button in front of carousel.
- If there is no reagent cassette, load one or more on specific positions.
- Check status of dilution plate and B.R.A.H.M.S KRYPTOR compact SOLUTIONS 1 to 4 on interface, according to necessity, change or load new consumables.

<b>Prepared By :</b> Ms. Gopika S. L. <b>Designation:</b> Laboratory Technician (P-5410)	<b>Signature:</b> 	<b>Issue Date :</b> 09.07.2021	<b>Page No</b> 80
<b>Verified By :</b> Dr. Dinoop K. P. <b>Designation:</b> Assistant Professor, Microbiology	<b>Signature:</b> 	<b>Revision No:</b>	<b>Copy no:</b> Controlled
<b>Issued By :</b> Dr. Kavita Raja <b>Designation:</b> Professor & Head, Microbiology	<b>Signature :</b> 	<b>ICMR Extramural Adhoc: P-5410</b>	

**Department of Microbiology**  
**Sree Chitra Tirunal Institute for Medical Sciences and Technology (SCTIMST)**

- Load kits on reagent tray when temperature status is green.
- Ensure the reagent lid is well closed.

**After an automatic change of day**

The automatic change of day procedure is launched every day, on the first ready or initialized stage after midnight. This will perform automatically all the initializations (init pipettor + init reader). Nevertheless, the user will have a logon to perform manual maintenances and database maintenance. User is warned that he has to logon with the message “KRYPTOR compact – Change of day made – Maintenance needed” in the title of the window. User can go on using the analyser, without logon, in case of use by night team, who wants that maintenance is performed by “morning team”.

**Maintenance**

Items on the maintenance screens only need to be performed if they are marked **\*Expired\***.

(!) These procedures will be performed automatically when the system has been started.



**Daily maintenance**

- **Initialize pipettor (!)**. To be done only if problems occur during run on pipettor module.
- **Initialize reader (!)**. To be done only if problems occur during run on reader module.
- **Prime Liquid Handling System (!)**. Check visually the absence of leaks and bubbles during the priming procedure.
- **Check and clean reader head window** by using a cotton-swab first with water then with alcohol.
- **Check and clean condensation in Reagent cassettes** with absorbent paper.
- **LIS end of day**. This action enables to purge LIS files and avoid the occurrence of data transmission problems.
- **Check dilution plate cleanness**. Look at dilution plate already on board if there is no dirty particles in dilution well.

**Weekly maintenance**

- **Check for liquid leaks**. Open fluidic hood to check the tubing system (tubing connectors, syringes).

When fluidic hood is closed, pipettor initialization is automatically done.

<b>Prepared By :</b> Ms. Gopika S. L. <b>Designation:</b> Laboratory Technician (P-5410)	<b>Signature:</b> 	<b>Issue Date :</b> 09.07.2021	<b>Page No</b> 81
<b>Verified By :</b> Dr. Dinoop K. P. <b>Designation:</b> Assistant Professor, Microbiology	<b>Signature:</b> 	<b>Revision No:</b>	<b>Copy no:</b> <b>Controlled</b>
<b>Issued By :</b> Dr. Kavita Raja <b>Designation:</b> Professor & Head, Microbiology	<b>Signature :</b> 	<b>ICMR Extramural Adhoc: P-5410</b>	

**Department of Microbiology**  
**Sree Chitra Tirunal Institute for Medical Sciences and Technology (SCTIMST)**

- **Tip path cleaning with decontamination solution** to clean up serum splashes with a paper towel slightly wet with water, then repeat with alcohol or specific product to decontaminate.
- **Backup DataBases.** Backup of all databases older than 3 days.
- **Backup Log Files.** Backup of log of run and maintenance log files.
- **Remove messages from box office.** This action enables the purge of the box office and avoid the occurrence of data transmission problems.
- **Cleaning of water bottle.** Empty and replace distilled/demineralized water if it is more than seven days old.
- **Clean carousel pan.** Clean the tray under the sample carousel with a paper towel slightly wet with water, then repeat with alcohol or specific product to decontaminate.

**Monthly maintenance**

- **Bottles decontamination.** Empty the bottles and pour in 1 liter of 5% sodium hypochlorite solution. Fit a bottle cap and swirl the liquid inside the bottle so that it comes into contact with all the internal surfaces. Allow to stand for 15 minutes, then empty and rinse the bottle with water.
- **Secure tip cleaning.** Tip parking over night or if instrument is not in use for a longer time. B.R.A.H.M.S KRYPTOR compact SOLUTION 3 and 4 must be available.
- **Automatic check dot.** Tip coming on dot point. If adjustment is correct, tip coming back to washcup. In case of adjustment problem, user should open the fluidic hood and check if tip can be slightly bent to enter the hole.



**Reagent registration**

For the following working steps installation of valid version of K-DISK K NN is needed.

Necessary when using new lots only:

**Reagent**

- Click on **Reagent Lot Manager:** 
- Click on **Register.**
- Scan the barcode sheet.

<b>Prepared By :</b> Ms. Gopika S. L. <b>Designation:</b> Laboratory Technician (P-5410)	<b>Signature:</b> 	<b>Issue Date :</b> 09.07.2021	<b>Page No</b> 82
<b>Verified By :</b> Dr. Dinoop K. P. <b>Designation:</b> Assistant Professor, Microbiology	<b>Signature:</b> 	<b>Revision No:</b>	<b>Copy no:</b> <b>Controlled</b>
<b>Issued By :</b> Dr. Kavita Raja <b>Designation:</b> Professor & Head, Microbiology	<b>Signature :</b> 	<b>ICMR Extramural Adhoc: P-5410</b>	

**Department of Microbiology**  
**Sree Chitra Tirunal Institute for Medical Sciences and Technology (SCTIMST)**

- Click on **OK** and confirm the registration with **Yes**.

**Calibrator**

- Click on **Calibrator/Standard Manager:** 

- Click on **Register**.

- Scan the barcode sheet.

- Click on **OK** and confirm the registration with **Yes**.

**Control**

- Click on: 

- Click on: 

- Click on **Register new Controls**.

- Scan the barcode sheet.

- Click on **OK**.

**Reconstitution of reagents**

- Click on  to start reconstitution process.

- All freeze dried reagent kits placed in the instrument will be reconstituted.

- In the status bar the progression of the reconstitution in % is visible.

**Perform a calibration**

**Calibrator**

- Double click on the kit you want to calibrate.

- Select a calibrator lot from the drop-down arrow list.

- Click on **add to worklist, OK, Close**.



- Request a carousel hood opening by pressing on blue button in front of instrument.

- Place the calibrator tube on the sample carousel making sure the barcode fills the slot.

- Close the carousel hood.



- Start the instrument: 



<b>Prepared By :</b> Ms. Gopika S. L. <b>Designation:</b> Laboratory Technician (P-5410)	<b>Signature:</b> 	<b>Issue Date :</b> 09.07.2021	<b>Page No</b> 83
<b>Verified By :</b> Dr. Dinoop K. P. <b>Designation:</b> Assistant Professor, Microbiology	<b>Signature:</b> 	<b>Revision No:</b>	<b>Copy no:</b> Controlled
<b>Issued By :</b> Dr. Kavita Raja <b>Designation:</b> Professor & Head, Microbiology	<b>Signature :</b> 	<b>ICMR Extramural Adhoc: P-5410</b>	

**Department of Microbiology**  
**Sree Chitra Tirunal Institute for Medical Sciences and Technology (SCTIMST)**

**Results**

- Open results list: 
- Select the calibrator result and click on **Validate curve**.
- The software indicates if the new calibration curve is acceptable or not:  
 if Yes click on: 
- if No click on: 

**Run controls**



**Control**



- Select **Q dd control** in the **Data, Worklist**: 
- Select a control from the list, press **Add to worklist, Close, Close**.
- Request a carousel hood opening by pressing on blue button in front of instrument.
- Place the control tube on the sample carousel making sure the barcode fills the slot.



- Close the carousel hood.
- Start the instrument: 



**Results**

- Open results list: 
- If result is in “needs resolution” status related to concentration out of 2SD range (shown in red) or with flag, check the information and validate, reject or relaunch the test. accepting the control automatically sends the result to the QC program.
- Select the B.R.A.H.M.S KRYPTOR compact Quality control program  to follow control life. Run patient samples with barcode.

<b>Prepared By :</b> Ms. Gopika S. L. <b>Designation:</b> Laboratory Technician (P-5410)	<b>Signature:</b> 	<b>Issue Date :</b> 09.07.2021	<b>Page No</b> 84
<b>Verified By :</b> Dr. Dinoop K. P. <b>Designation:</b> Assistant Professor, Microbiology	<b>Signature:</b> 	<b>Revision No:</b>	<b>Copy no:</b> Controlled
<b>Issued By :</b> Dr. Kavita Raja <b>Designation:</b> Professor & Head, Microbiology	<b>Signature :</b> 	<b>ICMR Extramural Adhoc: P-5410</b>	

**Department of Microbiology**  
**Sree Chitra Tirunal Institute for Medical Sciences and Technology (SCTIMST)**

**Run Patient Samples with barcode**

- Select **Add sample** from **Data, Worklist:** 
- Enter the Sample ID. Cassette ID and Tube position are mandatory in case of sample without barcode.
- Select tests and dilutions from the displayed list, **Add**.
- Click on **Stat** to pipette a sample in priority.
- Click on **Low volume sample vial** if sample is in microcup.
- Select **Save sample** and continue with required samples, **Close**.
- Request a carousel hood opening by pressing on blue button in front of carousel part.
- Place sample tubes on the carousel making sure the barcode fills the slot.
- Close the carousel hood.
- Start the instrument: 



**Results**

- Open results list: 
- Select a test.
- It is possible to **Cancel** tests in detecting, or counting step or in pending, only in "Ready/..." status.
- Results needing resolution can be: **Accepted, Re-run or Rejected**.
- Select the results then **Print Status** or **Print Report** to print results.

**End of day**



**Shutdown (stand by modus)**

- Check inventory of reagents on board for tomorrow's workload.
- Check the level of waste, distilled or demineralized water and B.R.A.H.M.S KRYPTOR BUFFER.
- Check if the B.R.A.H.M.S KRYPTOR compact SOLUTION 3 and 4 is on board.
- Select  and confirm with **Yes**.
- Unload the reaction plate and confirm the popup window with **OK**.
- Close the transparent damper and confirm the popup window with **OK**.

<b>Prepared By :</b> Ms. Gopika S. L. <b>Designation:</b> Laboratory Technician (P-5410)	<b>Signature:</b> 	<b>Issue Date :</b> 09.07.2021	<b>Page No</b> 85
<b>Verified By :</b> Dr. Dinoop K. P. <b>Designation:</b> Assistant Professor, Microbiology	<b>Signature:</b> 	<b>Revision No:</b>	<b>Copy no:</b> <b>Controlled</b>
<b>Issued By :</b> Dr. Kavita Raja <b>Designation:</b> Professor & Head, Microbiology	<b>Signature :</b> 	<b>ICMR Extramural Adhoc: P-5410</b>	

**Department of Microbiology**  
**Sree Chitra Tirunal Institute for Medical Sciences and Technology (SCTIMST)**

**To power OFF the instrument**

- Remove dilution plate(s), samples, and reagents.
- Close carousel hood.
- Select  and confirm with **Yes**.
- Unload the reaction plate and confirm the popup window with **OK**.
- Close the transparent damper and confirm the popup window with **OK**.
- Instrument is washing, wait for the completion of steps (SOLUTION 3 and water washing) in case of instrument power off.
- Close B.R.A.H.M.S KRYPTOR compact software: 
- Close Windows by clicking on **Start** and **Turn off**.
- Switch OFF the PC, screen, printer and instrument.

**Analytes with Pre-incubation**



The assay of an analyte with a pre-incubation is composed of two phases:

**Pre-incubation or Phase I:** the system aspirates one of the 2 conjugates and the antigen (sample). The system dispenses the mixture into the reaction well and the pre-incubation starts.

**Phase II:** the system aspirates the second conjugate and dispenses it into the reaction well. At this moment the Out of Range detection starts. This leads to a specific operation of the interface to avoid losing tests in Phase I distributed into the reaction area. The final test result will be achieved through Phase I and Phase II using the same reagent kit. To alert the user that a kit is in use for Phase I and is required for Phase II, a padlock will appear on the user interface at the edge of the reagent kit as shown below. The kit should not be removed while the padlock is displayed.



At the same time, a flashing red square will appear in the top left corner of the screen.

<b>Prepared By :</b> Ms. Gopika S. L. <b>Designation:</b> Laboratory Technician (P-5410)	<b>Signature:</b> 	<b>Issue Date :</b> 09.07.2021	<b>Page No</b> 86
<b>Verified By :</b> Dr. Dinoop K. P. <b>Designation:</b> Assistant Professor, Microbiology	<b>Signature:</b> 	<b>Revision No:</b>	<b>Copy no:</b> <b>Controlled</b>
<b>Issued By :</b> Dr. Kavita Raja <b>Designation:</b> Professor & Head, Microbiology	<b>Signature :</b> 	<b>ICMR Extramural Adhoc: P-5410</b>	

**Department of Microbiology**  
**Sree Chitra Tirunal Institute for Medical Sciences and Technology (SCTIMST)**

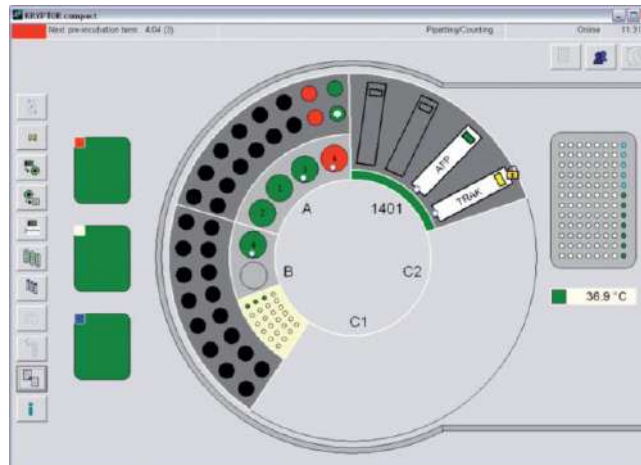

The message behind the red square indicates the estimated time in minutes and seconds remaining of Phase I. There is also a number in parentheses to show the number of tests in Phase I.

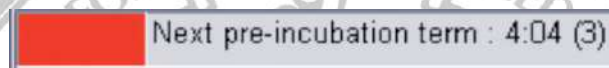

By reading this message the user can estimate the time available to open and The padlock is removed when the reagent kit has no tests remaining in Phase I, however the RED square can remain active if other tests in Phase I are underway. If the buffer bottle, water bottle, one of the solution bottles or the waste bottle is detected in red status during Phase I or Phase II, pipetting will stop and a popup window on interface informs to replace the solution. In Phase II the carousel hood will be opened by the system software and a beeping sound will alert the user. A user request to open the carousel hood during Phase I is subject to confirmation by the user via a message appearing on the screen.

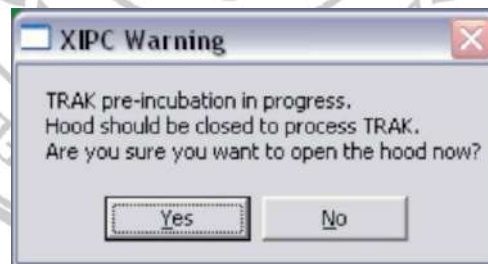

Clicking on the “Yes” button allows the hood to be opened with a beeping sound to alert the user and a new text message next to the red flashing square indicating the time available for the user to close the hood. Clicking on “No” led to the abandonment of the application to open the carousel hood.

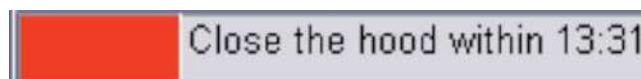

<b>Prepared By :</b> Ms. Gopika S. L. <b>Designation:</b> Laboratory Technician (P-5410)	<b>Signature:</b> 	<b>Issue Date :</b> 09.07.2021	<b>Page No</b> 87
<b>Verified By :</b> Dr. Dinoop K. P. <b>Designation:</b> Assistant Professor, Microbiology	<b>Signature:</b> 	<b>Revision No:</b>	<b>Copy no:</b> Controlled
<b>Issued By :</b> Dr. Kavita Raja <b>Designation:</b> Professor & Head, Microbiology	<b>Signature :</b> 	<b>ICMR Extramural Adhoc: P-5410</b>	

**Department of Microbiology**  
**Sree Chitra Tirunal Institute for Medical Sciences and Technology (SCTIMST)**

When closing the carousel hood, the text indicates the estimated time in minutes and seconds before the distribution of Phase II. When closing the hood, a carousel scan is performed. If a reagent kit containing a pre-incubation test was not found on board of the instrument, the user is notified via a message displayed on the interface:

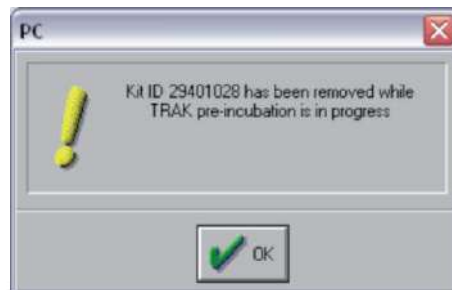

If the kit is not returned before the start of Phase II, any tests in progress with this kit will be declared failed. At the results list, the user can view the status of a test.

During Phase I, tests appear in blue with the message pre-incubating:



The start time of a test is given after the start of Phase II. If the test is failed during Phase I, the test is indicated in red with an alarm: "System error: Pre-incubation has failed."

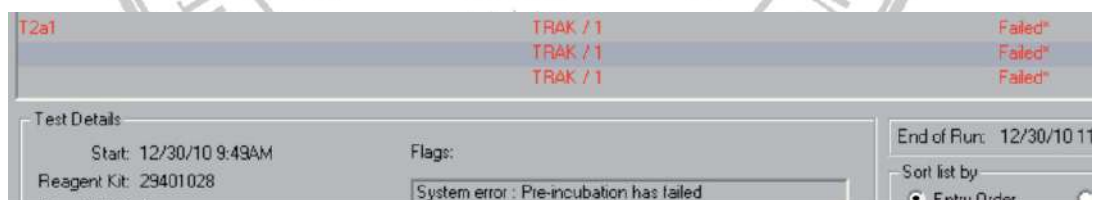

**Safety Precaution: Biohazardous**

When working with human serum, controls and calibrators all accessible parts of the analyzer must be considered as biohazardous. The pipette tip, sample cassettes, reagent cassettes, carousel drip pan, and analyzer deck should be routinely disinfected.

<b>Prepared By :</b> Ms. Gopika S. L. <b>Designation:</b> Laboratory Technician (P-5410)	<b>Signature:</b> 	<b>Issue Date :</b> 09.07.2021	<b>Page No 88</b>
<b>Verified By :</b> Dr. Dinoop K. P. <b>Designation:</b> Assistant Professor, Microbiology	<b>Signature:</b> 	<b>Revision No:</b>	<b>Copy no: Controlled</b>
<b>Issued By :</b> Dr. Kavita Raja <b>Designation:</b> Professor & Head, Microbiology	<b>Signature :</b> 	<b>ICMR Extramural Adhoc: P-5410</b>	

**Department of Microbiology**  
**Sree Chitra Tirunal Institute for Medical Sciences and Technology (SCTIMST)**

Concerning all areas exposed to patient potential infectious material or to user contact follow the cleaning requirements and use 5% Hypochloride solution for decontamination. (See B.R.A.H.M.S KRYPTOR compact PLUS Manual, chapter maintenance.) It is strongly recommended to wear gloves and a special coat.

**Waste**

The reagents and the waste must be disposed of as potential infectious laboratory waste according to local regulations.

**Dilution plate, reaction plate**

Before disposing of the dilution plate as well as the reaction plate stick the adhesive cover film with biohazard sign on the plate. The adhesive covers are supplied with the plates.

**B.R.A.H.M.S KRYPTOR compact SOLUTIONS 1 to 4**

For detailed information read the safety instructions for use inserts. Safety data sheets are available at International Product Support on request.



**Purpose of the Equipment:**

**Run Patient Samples for PCT**

- ✓ Select **Add sample** from **Data, Worklist**:
- ✓ Enter the **Sample ID, Cassette Number** and **Sample Tube Position** are added only if the tube has no barcode label.
- ✓ Select tests and dilutions from the displayed list by clicking on **Add**.
- ✓ **Save sample** and continue with required samples, **Close**.
- ✓ Place the sample tubes on the sample carousel.
- ✓ Close the hood.
- ✓ Start the instrument:

Click on the **Stat** box for an urgent sample to be processed next in line.

Click on the **Low Volume** box if using a low volume sample cup.

<b>Prepared By :</b> Ms. Gopika S. L. <b>Designation:</b> Laboratory Technician (P-5410)	<b>Signature:</b> 	<b>Issue Date :</b> 09.07.2021	<b>Page No</b> 89
<b>Verified By :</b> Dr. Dinoop K. P. <b>Designation:</b> Assistant Professor, Microbiology	<b>Signature:</b> 	<b>Revision No:</b>	<b>Copy no:</b> <b>Controlled</b>
<b>Issued By :</b> Dr. Kavita Raja <b>Designation:</b> Professor & Head, Microbiology	<b>Signature :</b> 	<b>ICMR Extramural Adhoc: P-5410</b>	

**Department of Microbiology**  
**Sree Chitra Tirunal Institute for Medical Sciences and Technology (SCTIMST)**

**Working with LIS**

- ✓ Make sure the KRYPTOR compact PLUS LIS program (KIM) is open.
- ✓ Place the sample tubes on the sample carousel.
- ✓ Close the hood.
- ✓ Start the instrument:



**Results**

- ✓ Select the results window:
- ✓ Select a test **"PCT"**
- ✓ Tests pending, detecting or counting can be cancelled, if necessary (only if the instrument's status is "Ready" and the pipetting procedures are stopped).
- ✓ Results needing resolution can be: **Accepted, Re-run or Rejected.**
- ✓ Select the results and then **Print Report** to print your results.

**Reference:**

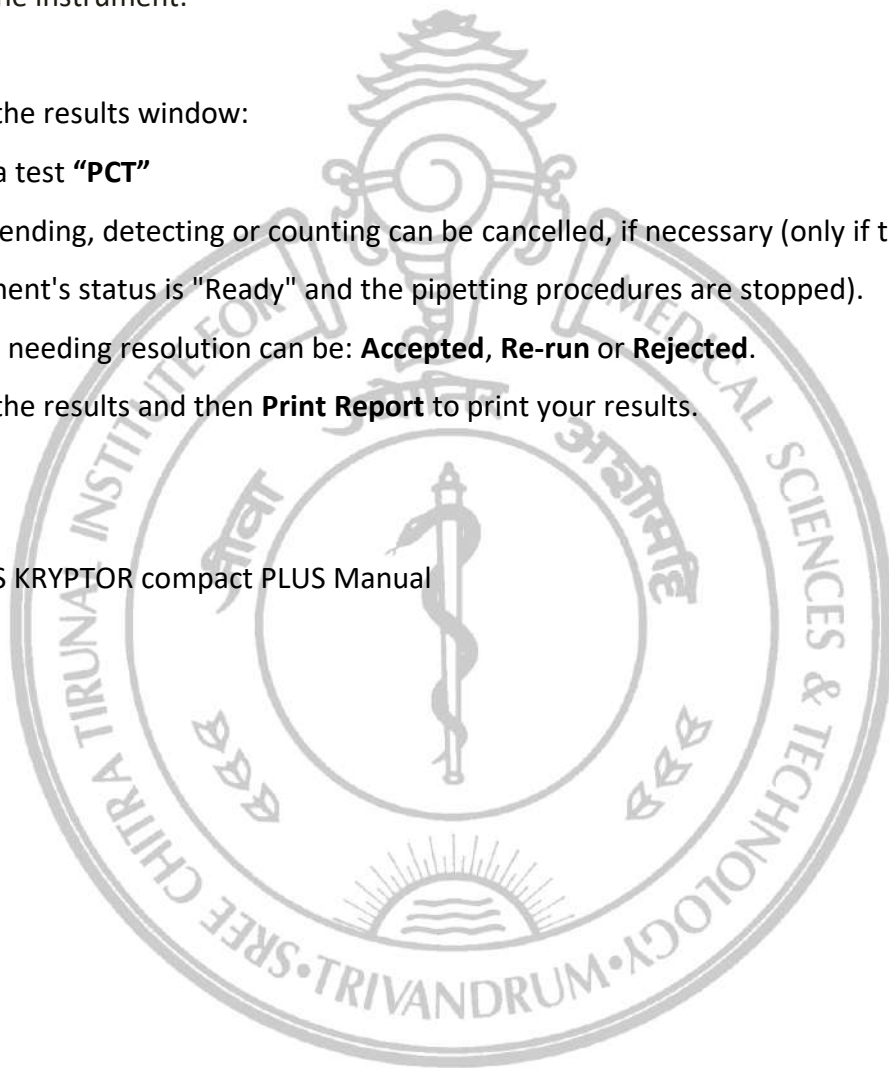
B·R·A·H·M·S KRYPTOR compact PLUS Manual



<b>Prepared By :</b> Ms. Gopika S. L. <b>Designation:</b> Laboratory Technician (P-5410)	<b>Signature:</b> 	<b>Issue Date :</b> 09.07.2021	<b>Page No</b> 90
<b>Verified By :</b> Dr. Dinoop K. P. <b>Designation:</b> Assistant Professor, Microbiology	<b>Signature:</b> 	<b>Revision No:</b>	<b>Copy no:</b> Controlled
<b>Issued By :</b> Dr. Kavita Raja <b>Designation:</b> Professor & Head, Microbiology	<b>Signature :</b> 	<b>ICMR Extramural Adhoc: P-5410</b>	

### 3. Dimension® RxL Max® clinical chemistry system





#### Introduction:

The Dimension® RxL Max® clinical chemistry system is a discrete, random access, microprocessor-controlled, integrated instrument/chemistry system that measures a variety of analytes, including enzyme activities, in body fluids.

For *in vitro* diagnostic use. It uses the Dade Behring Inc. Flex® multiple-test reagent cartridges, disposable reaction cuvettes, integrated multisensor technology (IMT) with the Dade Behring Inc. QuikLYTE® integrated multisensor to provide rapid, accurate, and precise test results, and the heterogeneous immunoassay (HM) module for processing of high sensitivity chromium-based heterogeneous immunoassays.



#### Features

- Performs tests in random order.
- Uses the Dade Behring Inc. low-cost-per-test Flex® reagent cartridge and onboard cuvette manufacturing system.
- Uses the Dade Behring Inc. exclusive QuikLYTE® integrated multisensor for Na, K, Cl testing.

<b>Prepared By :</b> Ms. Gopika S. L. <b>Designation:</b> Laboratory Technician (P-5410)	<b>Signature:</b> 	<b>Issue Date :</b> 09.07.2021	<b>Page No</b> 91
<b>Verified By :</b> Dr. Dinoop K. P. <b>Designation:</b> Assistant Professor, Microbiology	<b>Signature:</b> 	<b>Revision No:</b>	<b>Copy no:</b> Controlled
<b>Issued By :</b> Dr. Kavita Raja <b>Designation:</b> Professor & Head, Microbiology	<b>Signature :</b> 	<b>ICMR Extramural Adhoc: P-5410</b>	

**Department of Microbiology**  
**Sree Chitra Tirunal Institute for Medical Sciences and Technology (SCTIMST)**

- Performs up to 500 photometric chemistry tests and 300 Na, K, Cl tests per hour on serum, plasma, urine, or cerebrospinal fluid samples.
- Performs up to 167 heterogeneous immunoassays per hour.
- Performs automatic reflex testing.
- Performs automatic panic reruns.
- Uses various sizes of primary sample tubes.
- Uses 1.5-mL Dade Behring Inc. sample cups.
- Uses 1-mL Dade Behring Inc. SSC containers on top of barcoded tubes for short volume samples.
- Holds up to 44 Flex® reagent cartridges in a non-CFC refrigeration system and up to 88 Flex® reagent cartridges in a non-CFC refrigerated system when the Reagent Management System (RMS) module is installed.
- Performs automatic reagent preparation.
- Has an easy-to-use computer.
- Has ten user-programmable panel keys.
- Has the ability to link with other Dade Behring Inc. analyzers through the Dade Behring Inc. DataFusion® system integrator (either with or without bar code generation capability) or with a Laboratory Information System (LIS).
- Uses a 17-inch touchscreen monitor with visual/audio alerts.
- Uses the HIL feature to help determine usability of sample.
- Has the ability to produce calculated results.
- Has automatic rerun capability.
- Has automatic dilution for over range samples.
- Performs an automatic dilution on urine patient and urine QC samples.
- Has capability to process user-defined methods.
- Has the ability to automatically remove reagent cartridges when these cartridges are empty or their on-board life has expired.

<b>Prepared By :</b> Ms. Gopika S. L. <b>Designation:</b> Laboratory Technician (P-5410)	<b>Signature:</b> 	<b>Issue Date :</b> 09.07.2021	<b>Page No</b> 92
<b>Verified By :</b> Dr. Dinoop K. P. <b>Designation:</b> Assistant Professor, Microbiology	<b>Signature:</b> 	<b>Revision No:</b>	<b>Copy no:</b> <b>Controlled</b>
<b>Issued By :</b> Dr. Kavita Raja <b>Designation:</b> Professor & Head, Microbiology	<b>Signature :</b> 	<b>ICMR Extramural Adhoc: P-5410</b>	

**Department of Microbiology**  
**Sree Chitra Tirunal Institute for Medical Sciences and Technology (SCTIMST)**

- Provides for automatic calibration acceptance, and storage and retrieval of calibration results.
- Provides for off-instrument storage (diskette) of test results and calibration and QC records.
- Provides for barcoded QC panel processing.

**Major Components:**

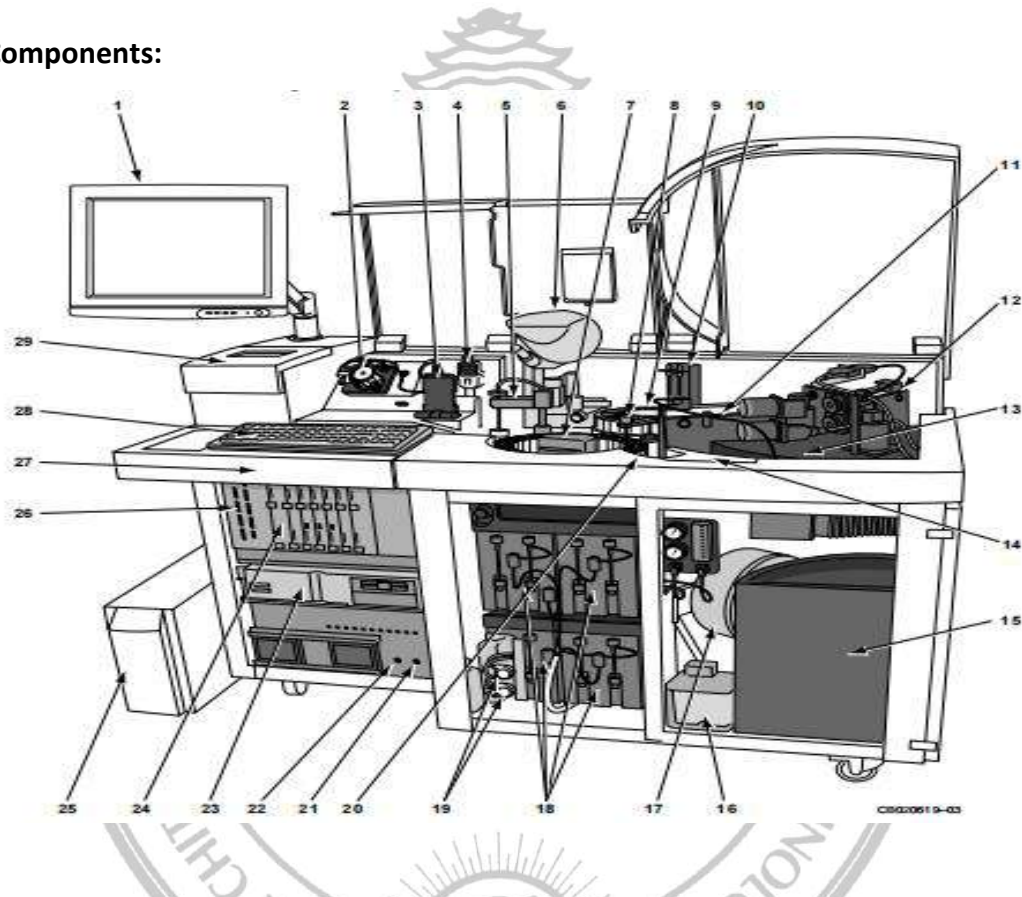

- |                                |                                |   |
|--------------------------------|--------------------------------|---|
| 1. Touchscreen monitor         | 11. R1 reagent arm             | 21. Interlock override switch                             |
| 2. IMT peristaltic pump        | 12. R2 reagent arm             | 22. Main power switch                                     |
| 3. QuikLYTE® sensor holder     | 13. Reagent cartridge tray     | 23. Computer hard drive                                   |
| 4. Monopump                    | 14. Cuvette manufacturing area | 24. System control boards                                 |
| 5. IMT probe                   | 15. Cuvette waste container    | 25. UPS   |
| 6. HM reaction vessel feeder   | 16. HM vessel waste container  | 26. DC fuse panel   |
| 7. Segmented sample area       | 17. Cuvette film cartridge     | 27. IMT standards and flush bags<br>(located under cover) |
| 8. Photometric sample probe    | 18. Sample, reagent, HM pumps  | 28. Keyboard  |
| 9. HM incubate and wash wheels | 19. HM probe cleaner pumps     | 29. System printer  |
| 10. HM wash probes             | 20. Automatic Flex® loader     |   |

<b>Prepared By :</b> Ms. Gopika S. L. <b>Designation:</b> Laboratory Technician (P-5410)	<b>Signature:</b> 	<b>Issue Date :</b> 09.07.2021	<b>Page No</b> 93
<b>Verified By :</b> Dr. Dinoop K. P. <b>Designation:</b> Assistant Professor, Microbiology	<b>Signature:</b> 	<b>Revision No:</b>	<b>Copy no:</b> <b>Controlled</b>
<b>Issued By :</b> Dr. Kavita Raja <b>Designation:</b> Professor & Head, Microbiology	<b>Signature :</b> 	<b>ICMR Extramural Adhoc: P-5410</b>	

**Major Components of the HM Module**

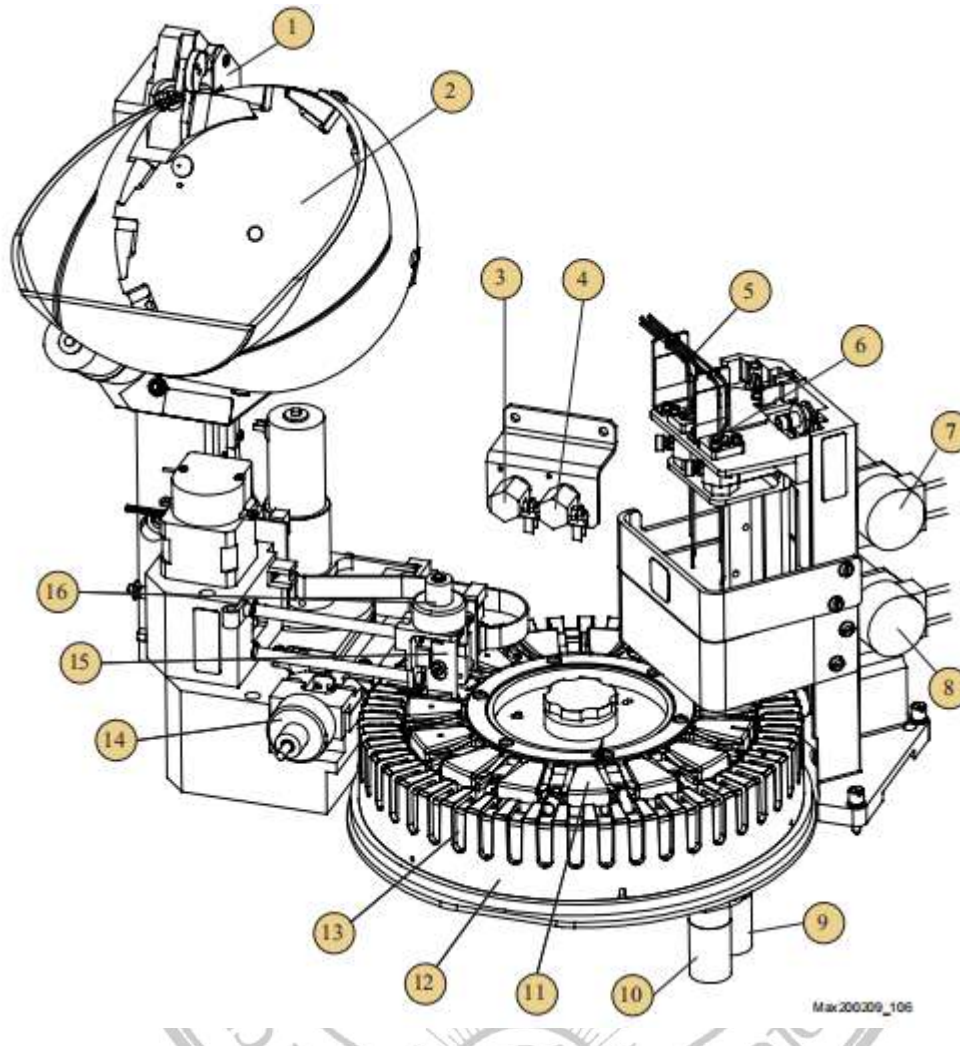

- |                               |  |
|-------------------------------|--|
| 1. Top of vessel feeder track | 9. Vessel mixer #2                       |
| 2. Vessel holder              | 10. Vessel mixer #1                      |
| 3. Vacuum sensor WP2          | 11. Wash wheel                           |
| 4. Vacuum sensor WP1          | 12. Incubate wheel                       |
| 5. Wash probe #2              | 13. Thermal ring (inside incubate wheel) |
| 6. Wash probe #1              | 14. Vessel gate solenoid                 |
| 7. Wash pump head #2          | 15. Vessel shuttle                       |
| 8. Wash pump head #1          | 16. Vessel shuttle guide solenoid        |

No tubing is shown in the illustration.

<b>Prepared By :</b> Ms. Gopika S. L. <b>Designation:</b> Laboratory Technician (P-5410)	<b>Signature:</b> 	<b>Issue Date :</b> 09.07.2021	<b>Page No</b> 94
<b>Verified By :</b> Dr. Dinoop K. P. <b>Designation:</b> Assistant Professor, Microbiology	<b>Signature:</b> 	<b>Revision No:</b>	<b>Copy no:</b> Controlled
<b>Issued By :</b> Dr. Kavita Raja <b>Designation:</b> Professor & Head, Microbiology	<b>Signature :</b> 	<b>ICMR Extramural Adhoc: P-5410</b>	

**Department of Microbiology**  
**Sree Chitra Tirunal Institute for Medical Sciences and Technology (SCTIMST)**

**Purpose of the Equipment:** Lactate estimation

**Switch ON the Instrument**

1. Plug the instrument power cord into its wall outlet.
2. Press the UPS ON/Test button.
3. Push the instrument main power switch to its up ( | ) position.
4. When the Operating Menu appears, run a System Check and your laboratory's daily QC to ensure that all instrument systems are operating properly.

**Adding Reagent Cartridges**

Reagent cartridges are placed into the instrument using the automatic loader. All you need to do is place the reagent cartridge in the loader. The Dimension® RxL Max® system will read the information on the barcode label and then move the cartridge into the reagent tray.

**Automatic Addition of Reagent Cartridges**

Place the reagent cartridge into the automatic loader so that its narrow end goes into the instrument first and its bar code label is on the right side of the cartridge.



**Sample Cups**

The Dade Behring Inc. sample cup will hold a maximum of 1.5 mL of sample. The dead volume in a Dade Behring Inc. sample cup is 50 µL.

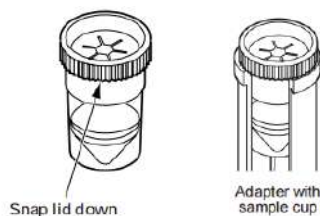

<b>Prepared By :</b> Ms. Gopika S. L. <b>Designation:</b> Laboratory Technician (P-5410)	<b>Signature:</b> 	<b>Issue Date :</b> 09.07.2021	<b>Page No</b> 95
<b>Verified By :</b> Dr. Dinoop K. P. <b>Designation:</b> Assistant Professor, Microbiology	<b>Signature:</b> 	<b>Revision No:</b>	<b>Copy no:</b> <b>Controlled</b>
<b>Issued By :</b> Dr. Kavita Raja <b>Designation:</b> Professor & Head, Microbiology	<b>Signature :</b> 	<b>ICMR Extramural Adhoc: P-5410</b>	

**Department of Microbiology**  
**Sree Chitra Tirunal Institute for Medical Sciences and Technology (SCTIMST)**

Sample cups must be placed into an adapter supplied by Dade Behring Inc. to load them into a segment. Push the sample cup completely down onto the adapter.

**Sample:** 54 µL CSF

**Loading Samples**

1. For samples without bar code labels, use the Load List screen to see the segment position you assigned to each sample. The words “**New Samples**” should be within the brackets in the upper right-hand corner of the Load List screen. If they are not, press **F2: Next Status**.
2. Ensure that any lids on sample cups are pressed down completely and that all stoppers have been removed from sample tubes.
3. Completely seat the correct sample container in its correct segment position. Remember to use the proper adapter for each sample container as necessary.
4. Position bar code labels so that the bar code is visible in the opening of the segment. They can then be read by the bar code scanners.



5. Completely seat the segment in its segment position on the sample wheel.



<b>Prepared By :</b> Ms. Gopika S. L. <b>Designation:</b> Laboratory Technician (P-5410)	<b>Signature:</b> 	<b>Issue Date :</b> 09.07.2021	<b>Page No</b> 96
<b>Verified By :</b> Dr. Dinoop K. P. <b>Designation:</b> Assistant Professor, Microbiology	<b>Signature:</b> 	<b>Revision No:</b>	<b>Copy no:</b> Controlled
<b>Issued By :</b> Dr. Kavita Raja <b>Designation:</b> Professor & Head, Microbiology	<b>Signature :</b> 	<b>ICMR Extramural Adhoc: P-5410</b>	

**Department of Microbiology**  
**Sree Chitra Tirunal Institute for Medical Sciences and Technology (SCTIMST)**

**Processing Samples for Lactate:**

1. Press **F1: NEW SAMPLE**

ENTER SAMPLE DATA	
Position: B1	Mode: SAMPLE CUP
Patient Name: Jones, Mary	Priority: ROUTINE
Sample No.: 42693	Fluid: CSF
Location: Rm101	Dilution:
Tests: Lactate	
Volume: 54 uL	

F1: NEW SAMPLE	F2: PROCESS SINGLE	F3: LOAD LIST	F4: NEXT PRIORITY
F5: DELETE TEST	F6: DELETE SAMPLE	F7: NEXT MODE	F8: NEXT FLUID



2. Press **RUN** Key on the keyboard

**Maintenance:**

**Daily Maintenance**

**Tools and supplies:**

- Cleaning the sample area
  - damp cloth
  - scissors
- Running a System Check
  - ABS reagent cartridge on instrument
  - fresh ABS solution from the *same lot* of ABS as the ABS reagent cartridge that is in the instrument.

<b>Prepared By :</b> Ms. Gopika S. L. <b>Designation:</b> Laboratory Technician (P-5410)	<b>Signature:</b> 	<b>Issue Date :</b> 09.07.2021	<b>Page No</b> 97
<b>Verified By :</b> Dr. Dinoop K. P. <b>Designation:</b> Assistant Professor, Microbiology	<b>Signature:</b> 	<b>Revision No:</b>	<b>Copy no:</b> Controlled
<b>Issued By :</b> Dr. Kavita Raja <b>Designation:</b> Professor & Head, Microbiology	<b>Signature :</b> 	<b>ICMR Extramural Adhoc: P-5410</b>	

**Department of Microbiology**  
**Sree Chitra Tirunal Institute for Medical Sciences and Technology (SCTIMST)**

**Weekly Maintenance**

Weekly maintenance is required only if your instrument is equipped with HM operation.

**Tools and supplies:**

- cotton swabs
- 0.1N sodium hydroxide
- water

**Monthly Maintenance**



**Only trained operators should perform these procedures.**

The monthly maintenance procedures are:

- Replacing IMT Pump Tubing
- Replacing the Monopump Valve Seal
- Cleaning the IMT System
- Replacing Instrument Air Filters If your instrument is equipped with the HM module, two additional procedures are required:
  - Replacing HM Pump Head
  - Styletting HM Wash Probes

**References:**

**Dimension® RxL Max®** clinical chemistry system Operator's Guide

<b>Prepared By :</b> Ms. Gopika S. L. <b>Designation:</b> Laboratory Technician (P-5410)	<b>Signature:</b> 	<b>Issue Date :</b> 09.07.2021	<b>Page No</b> 98
<b>Verified By :</b> Dr. Dinoop K. P. <b>Designation:</b> Assistant Professor, Microbiology	<b>Signature:</b> 	<b>Revision No:</b>	<b>Copy no:</b> Controlled
<b>Issued By :</b> Dr. Kavita Raja <b>Designation:</b> Professor & Head, Microbiology	<b>Signature :</b> 	<b>ICMR Extramural Adhoc: P-5410</b>	

#### 4. ELx50™ Microplate Strip Washer





##### Intended Use:

- The ELx50™ Microplate Strip Washer provides microplate priming and washing for ELISA, fluorescence and chemiluminescence immunoassays, cellular and agglutination assays.
- The intended use of this instrument is dependent on the instrument's rear panel label. If there is an IVD label, then the instrument may be used for clinical, research and development, or other non-clinical purposes. If there is no such label, then the instrument may only be used for research and development, or for other non-clinical purposes.

##### Introduction:

Fast, versatile, and easy to use, the ELx50™ is a user-programmable, fully automated microplate strip washer. Its key features include the following:

- The precision syringe pump with its long-lasting seal ensures precise fluid delivery, as well as reproducibility from wash to wash.
- Programmable dispense volumes, flow, and height, and aspiration rates and depths provide for a wide range of washing capabilities, from gentle washing for cellular assays to vigorous washing for ELISA.

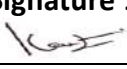

<b>Prepared By :</b> Ms. Gopika S. L. <b>Designation:</b> Laboratory Technician (P-5410)	<b>Signature:</b> 	<b>Issue Date :</b> 09.07.2021	<b>Page No</b> 99
<b>Verified By :</b> Dr. Dinoop K. P. <b>Designation:</b> Assistant Professor, Microbiology	<b>Signature:</b> 	<b>Revision No:</b>	<b>Copy no:</b> Controlled
<b>Issued By :</b> Dr. Kavita Raja <b>Designation:</b> Professor & Head, Microbiology	<b>Signature :</b> 	<b>ICMR Extramural Adhoc: P-5410</b>	

**Department of Microbiology**  
**Sree Chitra Tirunal Institute for Medical Sciences and Technology (SCTIMST)**

- The optional bottom washing routine can be applied to lower the background absorbance. The optional crosswise aspiration routine can be applied to reduce residual volumes.
- The ELx50 can be used to wash all microplate-based assays, including ELISA, fluorescence, chemiluminescence, RIA, DNA probes, and cellular assays.
- The intuitive menu-driven software allows you to create and store up to 75 washer programs. When you are ready to run a program, simply select the program name and follow the screen prompts. The ELx50 will then process the plate according to the program parameters.
- All ELx50 models support Wash, Prime, Dispense, and Aspirate programs. Some models also support Soak and Link programs.
- Several pre-defined programs are provided to simplify preventative maintenance, which should be performed regularly to ensure optimum washer performance.
- All ELx50 models can be used to wash standard 96-well microplates, and some models are also equipped to wash standard 384-well microplates.
- “V” versions of the ELx50 feature automatic wash buffer switching with three valves.
- The Liquid Level Alert™ option allows users the convenience of continuous monitoring for both supply and waste bottles. At the beginning and end of a wash protocol, the liquid level is verified to ensure sufficient wash buffer remains in the designated dispense bottle to complete a microplate wash. Sufficient storage capacity in the waste bottle is also verified. Each Liquid Level Alert kit includes a quantity of supply and waste bottles with level-sensing capability. Up to three different supply bottles can be connected to the washer through the Liquid Level Alert Select Box.
- An aspiration carrier is provided with the ELx50/8FMW model for bottom aspiration of filter bottom microplates. A vent port on the carrier and two selectable vent plugs for altering the diameter of the port provide three vacuum levels: low, medium, and high. Plates with filter pore sizes from 0.45 µm to 1.2 µm are supported.

**ELx50 Washer Variations**

There are several different ELx50™ washer models available: the ELx50/8, ELx50/12, ELx50/16, and ELx50/8FMW. Each washer comes with one of four possible washer manifolds (8-, 8s-, 12-, or 16 channel positioned above the microplates), and “V” version washers include automatic buffer switching with three valves. All models support the Liquid Level Alert™ option.

<b>Prepared By :</b> Ms. Gopika S. L. <b>Designation:</b> Laboratory Technician (P-5410)	<b>Signature:</b> 	<b>Issue Date :</b> 09.07.2021	<b>Page No</b> 00
<b>Verified By :</b> Dr. Dinoop K. P. <b>Designation:</b> Assistant Professor, Microbiology	<b>Signature:</b> 	<b>Revision No:</b>	<b>Copy no:</b> <b>Controlled</b>
<b>Issued By :</b> Dr. Kavita Raja <b>Designation:</b> Professor & Head, Microbiology	<b>Signature :</b> 	<b>ICMR Extramural Adhoc: P-5410</b>	

**Department of Microbiology**  
**Sree Chitra Tirunal Institute for Medical Sciences and Technology (SCTIMST)**

**Manifold Variations:**

The manifold is the washer component positioned above the microplate that delivers fluid to, and removes it from, the microwells. Each ELx50 washer is equipped with a manifold containing 8, 12, or 16 sets of aspirate and dispense tubes, or “channels.” The following table shows the washing capabilities of each manifold:



<b>With this manifold:</b>	<b>You can wash:</b>
8-channel	8-well strips, 96-well plates
8s-channel	8-well strips, 96-well plates
12-channel	12-well strips, 96-well plates
16-channel	8-well strips, 96-well plates, 384-well plates

The ELx50 supports the washing of standard flat, round, and ‘V’ bottom microwells; the ELx50/8FMW model also supports bottom aspiration of filter-bottom plates.

1. The 8s-channel manifold has shorter dispense tubes for special applications.
2. The 16-channel manifold uses two aspirate tubes for each well when used with 8-well strips and 96-well plates. For these formats, it may be difficult for the tubes to reach the very bottom of round or ‘V’ bottom wells, possibly leading to higher residuals.
3. The ELx50/8FMW model does not support the 16-channel manifold.

**Patented Dual-Manifold Design:**

The patented Dual-Action™ 16-channel manifold has 16 sets of dispense and aspirate tubes arranged in a fixed horizontal position relative to each other but located in two separate manifolds (see **Figure** below). The two manifolds move independently of each other on the vertical axis. This dual-manifold design overcomes the problem of fitting both a dispense and an aspirate tube into the much smaller 384-well at the same time, yet it allows for overflow washing of the smaller 384 wells. The dispense tubes are held above the plate when the dispense manifold reaches a mechanical stop, while the aspirate tubes are able to continue descending into the wells.

<b>Prepared By :</b> Ms. Gopika S. L. <b>Designation:</b> Laboratory Technician (P-5410)	<b>Signature:</b> 	<b>Issue Date :</b> 09.07.2021	<b>Page No</b> 01
<b>Verified By :</b> Dr. Dinoop K. P. <b>Designation:</b> Assistant Professor, Microbiology	<b>Signature:</b> 	<b>Revision No:</b>	<b>Copy no:</b> Controlled
<b>Issued By :</b> Dr. Kavita Raja <b>Designation:</b> Professor & Head, Microbiology	<b>Signature :</b> 	<b>ICMR Extramural Adhoc: P-5410</b>	

**Department of Microbiology**  
**Sree Chitra Tirunal Institute for Medical Sciences and Technology (SCTIMST)**

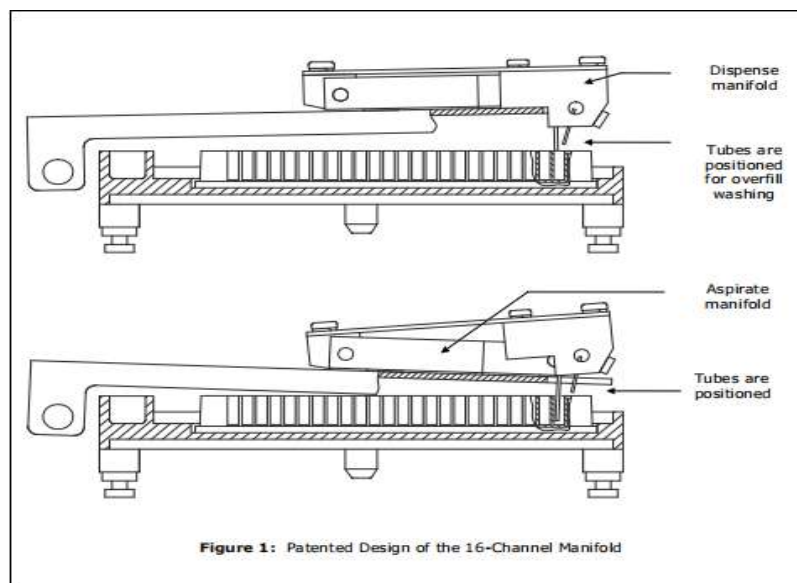

**Carrier Variations:**

The **carrier** is the washer component that transports microplates and positions the wells underneath the manifold tubes. There are three possible carrier types, and their usage depends on the manifold type installed and the microplate type being used:

- Microplate carrier that supports 8-, 8s-, and 12-channel manifolds and solid-bottom plates.
- Microplate carrier that supports 16-, 8-, and 8s-channel manifolds and solid-bottom plates.
- “Aspiration carrier” that supports 8- and 8s-channel manifolds and 96-well filter-bottom plates.

**Software Variations:**

The ELx50™ washer is operated by onboard software, controllable through the washer’s keypad. This onboard software, referred to as the “basecode,” has an identifying part number. Your washer is installed with one of three possible ELx50 basecode part numbers. Each part number in turn has an identifying version number.

**Hardware Features**

- 2-line x 24-character LCD display.
- Membrane keypad with 25 alphanumeric keys.



<b>Prepared By :</b> Ms. Gopika S. L. <b>Designation:</b> Laboratory Technician (P-5410)	<b>Signature:</b> 	<b>Issue Date :</b> 09.07.2021	<b>Page No</b> 02
<b>Verified By :</b> Dr. Dinoop K. P. <b>Designation:</b> Assistant Professor, Microbiology	<b>Signature:</b> 	<b>Revision No:</b>	<b>Copy no:</b> <b>Controlled</b>
<b>Issued By :</b> Dr. Kavita Raja <b>Designation:</b> Professor & Head, Microbiology	<b>Signature :</b> 	<b>ICMR Extramural Adhoc: P-5410</b>	

**Department of Microbiology**  
**Sree Chitra Tirunal Institute for Medical Sciences and Technology (SCTIMST)**

- Washes:
  1. 96-well microplates with 0.355" / 9 mm well centers
  2. 384-well microplates with 0.177" / 4.5 mm well centers (washer model-dependent)
  3. 96-well filter-bottom microplates (ELx50™/8FMW model only)
  4. 1 x 8 or 1 x 12 microwell strips
- Crosswise aspiration for optimizing washing performance.
- External 24-volt power supply.
- One serial RS-232 COM port (25-pin male connector).
- Supply and waste systems appropriate
- Internal positive displacement pump provides controllable flow rates and volumes to make washing cellular assays and immuno assays equally convenient.
- Internal vacuum pump aspirates liquid from the microwells into the waste collection vacuum vessel.
- Stepper motors provide accurate and repeatable carrier and manifold positioning.
- Accommodates 1 x 8, 1 x 12, or 1 x 16 manifolds.
- Flat, round and 'V' bottomed strips and plates are washed.
- Carrier and manifold are easily removed for cleaning.
- Priming/soaking trough built into the carrier.
- Five shaking speeds for more intense washing.
- Programmable aspiration depth: Ensures that the tubes do not touch the well bottom, allowing the handling of sensitive cell assays.
- ELx50/8FMW model: one vent port (0.047" in diameter) on the aspiration carrier and two selectable vent plugs (with 0.032" and 0.020" diameter holes) for varying the amount of vacuum used with the aspiration carrier.
- Mist shield protects the microplate from contaminants.

**Accessories Included**

- 8-, 8s-, 12-, or 16-channel manifold
- Microplate carrier (specific to manifold type)
- Aspiration carrier

<b>Prepared By :</b> Ms. Gopika S. L. <b>Designation:</b> Laboratory Technician (P-5410)	<b>Signature:</b> 	<b>Issue Date :</b> 09.07.2021	<b>Page No</b> 03
<b>Verified By :</b> Dr. Dinoop K. P. <b>Designation:</b> Assistant Professor, Microbiology	<b>Signature:</b> 	<b>Revision No:</b>	<b>Copy no:</b> Controlled
<b>Issued By :</b> Dr. Kavita Raja <b>Designation:</b> Professor & Head, Microbiology	<b>Signature :</b> 	<b>ICMR Extramural Adhoc: P-5410</b>	

**Department of Microbiology**  
**Sree Chitra Tirunal Institute for Medical Sciences and Technology (SCTIMST)**

- Mist shield
- Two 2-liter supply bottles (three with “V” version washers)
- One 2-liter waste bottle
- Waste tubing set
- Supply tubing set
- Optional in-line vacuum filter
- Optional vacuum pump muffler for ELx50 washers that are equipped with the new vacuum pump
- Aspirate tube stylus and Dispense tube stylus

**Specifications**

**Microplates**

- Microplates: 96-well, 384-well solid-bottom plates and 96-well filter-bottom plates, 0.45 µm to 1.2 µm filter pore size (ELx50™/8FMW)
- Microstrips: 1 x 8, 1 x 12
- Microwells: Flat, round, or “V” bottom
- 384-well support is available with the 16-channel manifold only.

**Electrical**



- Voltage range: 100 to 250 V~, 50 to 60 Hz
- Power Consumption: 40 W

**Physical**

- Dimensions: 16 in. D x 14 in. W x 6.5 in. H (40.6 cm x 35.6 cm x 16.5 cm)
- Weight: ≤ 20 lbs. (8.9 kg) all models except ELx50/8FMW; ≥ 22 lbs. (9 kg) ELx50/8FMW model

**Environmental**

- Operating conditions: 15° - 40°C (59° - 104°F)
- Relative humidity: 10% - 85% (non-condensing)

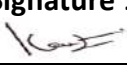
<b>Prepared By :</b> Ms. Gopika S. L. <b>Designation:</b> Laboratory Technician (P-5410)	<b>Signature:</b> 	<b>Issue Date :</b> 09.07.2021	<b>Page No</b> 04
<b>Verified By :</b> Dr. Dinoop K. P. <b>Designation:</b> Assistant Professor, Microbiology	<b>Signature:</b> 	<b>Revision No:</b>	<b>Copy no:</b> Controlled
<b>Issued By :</b> Dr. Kavita Raja <b>Designation:</b> Professor & Head, Microbiology	<b>Signature :</b> 	<b>ICMR Extramural Adhoc: P-5410</b>	

**Department of Microbiology**  
**Sree Chitra Tirunal Institute for Medical Sciences and Technology (SCTIMST)**

**Hardware**

- Manifold type: 8-, 8s-, 12-, or 16-channel manifold, depending on washer model
- Waste bottle volume: 2 liters
- Supply bottle volume: 2 liters
- User interface (LCD): 2 x 24 LCD display; 25 alphanumeric soft keys

**ELx50 Front Panel**

The front panel on the ELx50™ Microplate Strip Washer features a 25-key keypad and a 2 x 24-character LCD display as shown as below.

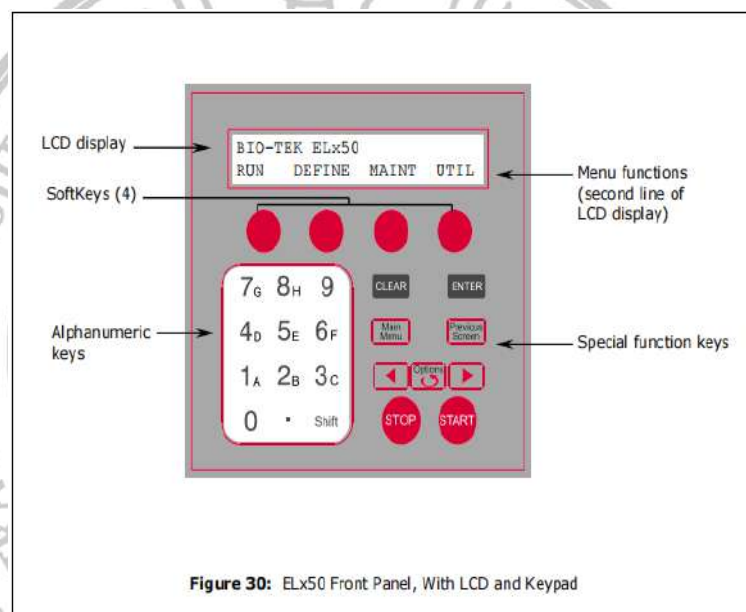



<b>Prepared By :</b> Ms. Gopika S. L. <b>Designation:</b> Laboratory Technician (P-5410)	<b>Signature:</b> 	<b>Issue Date :</b> 09.07.2021	<b>Page No</b> 05
<b>Verified By :</b> Dr. Dinoop K. P. <b>Designation:</b> Assistant Professor, Microbiology	<b>Signature:</b> 	<b>Revision No:</b>	<b>Copy no:</b> Controlled
<b>Issued By :</b> Dr. Kavita Raja <b>Designation:</b> Professor & Head, Microbiology	<b>Signature :</b> 	<b>ICMR Extramural Adhoc: P-5410</b>	

**Department of Microbiology**  
**Sree Chitra Tirunal Institute for Medical Sciences and Technology (SCTIMST)**

**Keypad Description**

- 

The keypad has four **SoftKeys**, one below each selectable menu option. Press a SoftKey to choose a menu selection. For example, from the **Main Menu**, press the leftmost SoftKey to select **RUN**, the rightmost to select **UTIL**.
- 

Exit the current screen and return to the **Main Menu**. After defining a washer program, press the **Main Menu** key, then press **YES** to save the program.
- 

To scroll through the different options within a program, press the **Options** key or the **Shift + Options** key combination. Press the **ENTER** key to select the current option.
- 

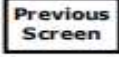
Pressing **ENTER** generally saves the current screen settings and advances to the next screen in a series.
- 

To move to a previous menu, press the **Previous Screen** key.
- 

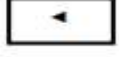
Press **CLEAR** to delete an entry.
- 

Press the ◀ (reverse) arrow to move the cursor to the left in the LCD display.
- 

Press the ▶ (forward) arrow to move the cursor to the right in the LCD display.
- 

To start running a washer program, press the **START** key.
- 



To stop running (abort) a washer program, press the **STOP** key.

**System Startup**

To turn on the ELx50™, press the on/off switch on the right side of the base. The ELx50 will perform a self-test, displaying the screens shown below until initialization is complete. During this time, all keys are inactive.

If the self-test fails, the washer will “chirp” and display an error code. Press **STOP** to stop the chirp.

POWERUP SEQUENCE V1.02  
 INITIALIZING. . .  
 (Instrument ID)  
 SYSTEM SELF-TEST. . .

<b>Prepared By :</b> Ms. Gopika S. L. <b>Designation:</b> Laboratory Technician (P-5410)	<b>Signature:</b> 	<b>Issue Date :</b> 09.07.2021	<b>Page No</b> 06
<b>Verified By :</b> Dr. Dinoop K. P. <b>Designation:</b> Assistant Professor, Microbiology	<b>Signature:</b> 	<b>Revision No:</b>	<b>Copy no:</b> <b>Controlled</b>
<b>Issued By :</b> Dr. Kavita Raja <b>Designation:</b> Professor & Head, Microbiology	<b>Signature :</b> 	<b>ICMR Extramural Adhoc: P-5410</b>	

**Department of Microbiology**  
**Sree Chitra Tirunal Institute for Medical Sciences and Technology (SCTIMST)**

### Wash

This section discusses how to run, define, edit, copy, and delete **Wash** programs.

### Run Wash Program

*Before running any program, make sure that the microplate or the holder containing the microstrips is properly seated in the plate carrier.*

To run a Wash program, follow the menu path shown here. Some of these items are options and some are prompts. The options are described below.

RUN → WASH → SELECT WASH PROGRAM → SELECT REAGENT BOTTLE\* → PRIME THE WASHER? → SELECT PRIME PROGRAM → FIRST STRIP → NUMBER OF STRIPS → PLACE PLATE IN CARRIER AND PRESS <START> KEY → WASH PROGRAM RUNNING. PRESS <STOP> KEY TO QUIT → WASH PROGRAM COMPLETE. PRESS <ENTER> KEY

\* SELECT REAGENT BOTTLE only appears on the “V” version washers.

### Prime

This section discusses how to define, run, edit, copy, and delete Prime programs.



### Define Prime Program

To define a Prime program, follow the menu path shown here. Some of these items are options and some are prompts. The options are described below.

DEFINE → CREATE → PRIME → NAME → PRIME VOLUME → PRIME FLOW RATE → SOAK AFTER PRIME? → SOAK DURATION → OK TO SAVE PROGRAM?

### Run Prime Program

To run a Prime program, follow the menu path shown here. Some of these items are options and some are prompts. The options are described below.

<b>Prepared By :</b> Ms. Gopika S. L. <b>Designation:</b> Laboratory Technician (P-5410)	<b>Signature:</b> 	<b>Issue Date :</b> 09.07.2021	<b>Page No</b> 07
<b>Verified By :</b> Dr. Dinoop K. P. <b>Designation:</b> Assistant Professor, Microbiology	<b>Signature:</b> 	<b>Revision No:</b>	<b>Copy no:</b> <b>Controlled</b>
<b>Issued By :</b> Dr. Kavita Raja <b>Designation:</b> Professor & Head, Microbiology	<b>Signature :</b> 	<b>ICMR Extramural Adhoc: P-5410</b>	

**Department of Microbiology**  
**Sree Chitra Tirunal Institute for Medical Sciences and Technology (SCTIMST)**

```
RUN → PRIME → SELECT PRIME PROGRAM → SELECT
REAGENT BOTTLE* → CONNECT REAGENT BOTTLE AND
PRESS <START> KEY → PRIME PROGRAM RUNNING.
PRESS <STOP> KEY TO QUIT → PRIME PROGRAM
COMPLETE. PRESS <ENTER> KEY
```

\* SELECT REAGENT BOTTLE only appears on the “V” version washers.

### Dispense

This section discusses how to define, run, edit, copy, and delete Dispense programs.

#### Define Dispense Program

To define a Dispense program, follow the menu path shown here. Some of these items are options and some are prompts. The options are described below.

```
DEFINE → CREATE → DISP → NAME → PLATE TYPE*
→ DISPENSE VOLUME → DISPENSE FLOW RATE →
DISPENSE HEIGHT → HORIZONTAL DISP POS → PRIME
BEFORE START? → PRIME VOLUME → PRIME FLOW RATE
→ OK TO SAVE PROGRAM?
```

1. PLATE TYPE only appears if the washer is configured with the 16-channel manifold.

### Aspiration



#### Define Aspiration Program

To define an Aspiration program, follow the menu path shown here. Some of these items are options and some are prompts. The options are described below.

```
DEFINE → CREATE → MORE → ASPIR → NAME → PLATE
TYPE* → ASPIRATE TYPE** → BOT ASPIRATE TIME**
→ ASPIRATE HEIGHT → HORIZONTAL ASPR POS →
ASPIRATION RATE → ASPIRATE DELAY → CROSSWISE
ASPIR? → CROSSWISE HEIGHT → CROSSWISE HORIZ POS
→ OK TO SAVE PROGRAM?
```

1. PLATE TYPE only appears if the washer is configured with the 16-channel manifold.

2. ASPIRATE TYPE and BOT ASPIRATE TIME only appear if the washer is an ELx50/8FMW and the manifold is configured as either 8- or 8s-channel.

<b>Prepared By :</b> Ms. Gopika S. L. <b>Designation:</b> Laboratory Technician (P-5410)	<b>Signature:</b> 	<b>Issue Date :</b> 09.07.2021	<b>Page No</b> 08
<b>Verified By :</b> Dr. Dinoop K. P. <b>Designation:</b> Assistant Professor, Microbiology	<b>Signature:</b> 	<b>Revision No:</b>	<b>Copy no:</b> Controlled
<b>Issued By :</b> Dr. Kavita Raja <b>Designation:</b> Professor & Head, Microbiology	<b>Signature :</b> 	<b>ICMR Extramural Adhoc: P-5410</b>	

**Department of Microbiology**  
**Sree Chitra Tirunal Institute for Medical Sciences and Technology (SCTIMST)**

**Setup**

**Manifold (MANIFLD)**

Your ELx50™ Microplate Strip Washer was initially configured for and shipped with an 8-, 12-, 8s-, or 16-channel wash manifold. It is important that the washer software configuration accurately represent the manifold installed in the instrument. If you change the hardware, you must also change the software configuration.

To view or change the configuration of the manifold to 8-, 12-, 8s-, or 16- channel, follow the washer menu path shown below:

```
UTIL → SETUP → MANIFLD → SELECT MANIFOLD:  
8    12*   8S   16**
```



1. For washers with the aspiration carrier (ELx50/8FMW model), if 12 is selected for the manifold, aspiration using the aspiration carrier is not available.
1. 16 will not be displayed on ELx50/8FMW washers.

```
DEFINE → EDIT → PRIME → SELECT PRIME PROGRAM  
→ Edit the Program Parameters → OK TO SAVE  
PROGRAM?
```

**Maintenance Programs**

The ELx50™ onboard software contains pre-defined maintenance programs, including DAY\_RINSE, RINSE\_AND\_SOAK, OVERNIGHT\_LOOP, DECONTAMINATION, and LONG\_SHUTDOWN. These programs are accessible from the washer main menu, under the MAINT option. To run a maintenance program:

1. From the Main Menu, select MAINT.
2. Select the desired maintenance program.
3. Press the **START** key to begin. To halt the maintenance program in progress, press **STOP**.
2. When the program is complete, press **ENTER** to return to the Main Menu.

<b>Prepared By :</b> Ms. Gopika S. L. <b>Designation:</b> Laboratory Technician (P-5410)	<b>Signature:</b> 	<b>Issue Date :</b> 09.07.2021	<b>Page No</b> 09
<b>Verified By :</b> Dr. Dinoop K. P. <b>Designation:</b> Assistant Professor, Microbiology	<b>Signature:</b> 	<b>Revision No:</b>	<b>Copy no:</b> <b>Controlled</b>
<b>Issued By :</b> Dr. Kavita Raja <b>Designation:</b> Professor & Head, Microbiology	<b>Signature :</b> 	<b>ICMR Extramural Adhoc: P-5410</b>	

**Department of Microbiology**  
**Sree Chitra Tirunal Institute for Medical Sciences and Technology (SCTIMST)**

**Daily Maintenance**

For all daily maintenance programs, ensure that the supply bottle contains at least 200 mL of rinse solution, and that the waste bottle is empty.

**DAY\_RINSE**



Daily maintenance involves flushing the washer with an appropriate reagent at the beginning of the day (BioTek recommends using a buffer solution in the morning). The DAY\_RINSE program is recommended for the morning. This should be done *on the same day the microplates are washed*. This procedure helps prevent the aspirate and dispense tubes from clogging between washes.

**Monthly Maintenance**

**Tools and Supplies**

- 70% isopropyl alcohol
- Deionized or distilled water
- Dish soap or other mild cleaner
- Aspirate tube stylus and Dispense tube stylus
- Phillips head screwdriver
- Lint-free disposable towels
- Soft-bristled brush
- Rubber stopper for waste bottle
- Spare vacuum inline filter
- Spare vacuum pump muffler
- Spare check valves (2)
- Spare manifold gasket (rubber seal)
- Spare gasket for aspiration carrier (rubber seal, ELx50™/8FMW)
- Spare vent plug o-rings for aspiration carrier (2 per plug, ELx50/8FMW)

**Reference: ELx 50 microplate Strip washer operator's manual**

<b>Prepared By :</b> Ms. Gopika S. L. <b>Designation:</b> Laboratory Technician (P-5410)	<b>Signature:</b> 	<b>Issue Date :</b> 09.07.2021	<b>Page No</b> 10
<b>Verified By :</b> Dr. Dinoop K. P. <b>Designation:</b> Assistant Professor, Microbiology	<b>Signature:</b> 	<b>Revision No:</b>	<b>Copy no:</b> Controlled
<b>Issued By :</b> Dr. Kavita Raja <b>Designation:</b> Professor & Head, Microbiology	<b>Signature :</b> 	<b>ICMR Extramural Adhoc: P-5410</b>	

### 5. ELx 800 Absorbance Microplate Reader

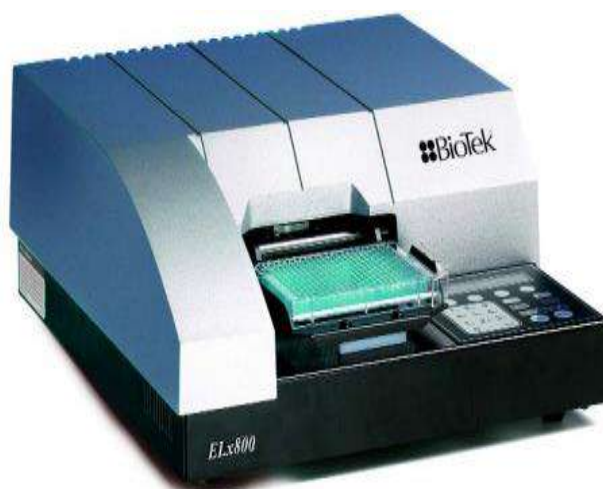

#### **Introduction:**



The ELx800 is a single-channel reader-assay system, designed to automatically perform endpoint analysis for ELISA-based applications. The reader has the following capabilities:

All models: Measurement of the optical density of solutions in 6-, 12-, 24-, 48-, or 96-well microplates.

“NB” models: Measurement of 384-well microplates and 60-, 72-, 96-well Terasaki trays as well as 6-, 12, 24-, 48-, and 96-well plates. Superior optical specifications, with an extended dynamic range of up to 3.000 absorbance units in some read modes. All models: A wavelength range from 400 nm to 750 nm. “UV” models: An extended range from 340 nm to 750 nm. Kinetic analysis can be performed using computer control (e.g., via Gen5, KC4, or KCjunior running on a host computer). Assay definitions (consisting of protocols, templates, and formulas) and the data they produce are managed by an onboard processor, via an LCD screen and membrane keypad. Data can be stored onboard, printed, and/or uploaded to controlling software on a host computer. Designed to serve as a stand-alone system, or as part of a larger laboratory data network, sending, receiving, and manipulating assay data as needed.

#### **Hardware Features**

- Single optics channel
- Wavelength range of 400-750 nm (“UV” model range is 340 to 750 nm)

<b>Prepared By :</b> Ms. Gopika S. L. <b>Designation:</b> Laboratory Technician (P-5410)	<b>Signature:</b> 	<b>Issue Date :</b> 09.07.2021	<b>Page No</b> 11
<b>Verified By :</b> Dr. Dinoop K. P. <b>Designation:</b> Assistant Professor, Microbiology	<b>Signature:</b> 	<b>Revision No:</b>	<b>Copy no:</b> <b>Controlled</b>
<b>Issued By :</b> Dr. Kavita Raja <b>Designation:</b> Professor & Head, Microbiology	<b>Signature :</b> 	<b>ICMR Extramural Adhoc: P-5410</b>	

**Department of Microbiology**  
**Sree Chitra Tirunal Institute for Medical Sciences and Technology (SCTIMST)**

- A 5-position filter wheel
- A 2-line x 24-character LCD display
- A membrane keypad with alphanumeric keys
- X-Y carrier movement
- Capability of reading 6-, 12-, 24-, 48- and 96-well microplates ("NB" model also reads 384-well and 60-/72-/96-well Terasaki microplates)
- External 24-volt power supply, compatible with 100-240 V~ ± 10.0% @ 50 to 60 Hz
- One serial COM port, 25-pin male connector
- One parallel port, 25-pin female connector



**Software Features**

- An easy-to-use, menu-driven interface
- Endpoint calculations
- Curve Fitting, with 4-parameter, cubic, quadratic, linear, 2-P, cubic-spline, and point-to-point methods
- Transformation and Formula calculations for more complex mathematical operations, including Validations
- Up to 75 assays can be programmed into memory and recalled instantly
- Up to 10 Results can be stored in memory

**Specifications**

**All Models:**

Light Source	Tungsten gas-filled bulb
Dimensions	42 cm x 38 cm x 18 cm (16.5" deep x 15" wide x 7" tall)
Weight	8 kg (18.5 lb. maximum)
Environment	Operating temperature 18° to 40°C
Humidity	10% to 85% non condensing
Power Supply	Input 100 to 240 V~ ± 10.0% @ 50 to 60 Hz Output +24 VDC, 2.1 A

<b>Prepared By :</b> Ms. Gopika S. L. <b>Designation:</b> Laboratory Technician (P-5410)	<b>Signature:</b> 	<b>Issue Date :</b> 09.07.2021	<b>Page No</b> 12
<b>Verified By :</b> Dr. Dinoop K. P. <b>Designation:</b> Assistant Professor, Microbiology	<b>Signature:</b> 	<b>Revision No:</b>	<b>Copy no:</b> Controlled
<b>Issued By :</b> Dr. Kavita Raja <b>Designation:</b> Professor & Head, Microbiology	<b>Signature :</b> 	<b>ICMR Extramural Adhoc: P-5410</b>	

**Department of Microbiology**  
**Sree Chitra Tirunal Institute for Medical Sciences and Technology (SCTIMST)**

**Standard Model:**

Wavelength Range	400 to 750 nm
Filters	10 nm half-bandwidth interference filters. User-accessible filter wheel. Up to 5 filters may be installed on the instrument at one time. Filters supplied: 405, 450, 490, and 630 nm.

*The following specifications apply to 96-well, flat- or round-bottom plates, single-wavelength measurements with a 50-second read (normal read mode):*



Absorbance Measurement Range	0.000 to 3.000 OD
Accuracy	± 1.0% ± 0.010 OD from 0.000 to 2.000 OD @ 405 nm
Linearity	± 1.0% from 0.000 to 2.000 OD at 405 nm
Repeatability (STD)	± 0.5% ± 0.005 OD from 0.000 to 2.000 OD @ 405 nm

*The following specifications apply to 96-well, flat- or round-bottom plates, single-wavelength measurements with a 30-second read (rapid read mode):*

Absorbance Measurement Range	0.000 to 3.000 OD
Accuracy	± 2.0% ± 0.020 OD from 0.000 to 2.000 OD @ 405 nm
Linearity	± 2.0% from 0.000 to 2.000 OD @ 405 nm
Repeatability (STD)	± 1.0% ± 0.010 OD from 0.000 to 2.000 OD @ 405 nm

**Ultraviolet/UV Model**

Wavelength Range	340 to 750 nm
Filters	10 nm half-bandwidth interference filters. User-accessible filter wheel. Up to 5 filters may be installed on the instrument at one time. Filters supplied: 340, 405, 450, 490, and 630 nm.

<b>Prepared By :</b> Ms. Gopika S. L. <b>Designation:</b> Laboratory Technician (P-5410)	<b>Signature:</b> 	<b>Issue Date :</b> 09.07.2021	<b>Page No</b> 13
<b>Verified By :</b> Dr. Dinoop K. P. <b>Designation:</b> Assistant Professor, Microbiology	<b>Signature:</b> 	<b>Revision No:</b>	<b>Copy no:</b> Controlled
<b>Issued By :</b> Dr. Kavita Raja <b>Designation:</b> Professor & Head, Microbiology	<b>Signature :</b> 	<b>ICMR Extramural Adhoc: P-5410</b>	

**Department of Microbiology**  
**Sree Chitra Tirunal Institute for Medical Sciences and Technology (SCTIMST)**

The following specifications apply to 96-well, flat- or round-bottom plates:

Optical specifications for 400-750 nm range (50-second read in normal read mode):

Absorbance Measurement Range	0.000 to 3.000 OD
Accuracy	± 1.0% ± 0.010 OD from 0.000 to 2.000 OD @ 405 nm
Linearity	± 1.0% from 0.000 to 2.000 OD @ 405 nm ± 3.0% from 2.000 to 3.000 OD @ 450 nm
Repeatability (STD)	± 0.5% ± 0.005 OD from 0.000 to 2.000 OD @ 405 nm

Optical specifications for 340-400 nm range (50-second read in normal read mode):

Absorbance Measurement Range	0.000 to 2.000 OD
Accuracy	± 2.0% ± 0.010 OD from 0.000 to 2.000 OD @ 340 nm
Linearity	± 2.5% from 0.000 to 2.000 OD @ 340 nm
Repeatability (STD)	± 1.5% ± 0.005 OD from 0.000 to 2.000 OD @ 340 nm

Optical specifications for 400-750 nm range (30-second read in rapid read mode):



Absorbance Measurement Range	0.000 to 3.000 OD
Accuracy	± 2.0% ± 0.020 OD from 0.000 to 2.000 OD @ 405 nm
Linearity	± 2.0% from 0.000 to 2.000 OD @ 405 nm
Repeatability (STD)	± 1.0% ± 0.010 OD from 0.000 to 2.000 OD @ 405 nm

Optical specifications for 340-400 nm range (30-second read):

Absorbance Measurement Range	0.000 to 2.000 OD
Accuracy	± 2.5% ± 0.020 OD from 0.000 to 2.000 OD @ 340 nm
Linearity	± 2.5% from 0.000 to 2.000 OD @ 340 nm
Repeatability (STD)	± 2.0% ± 0.010 OD from 0.000 to 2.000 OD @ 340 nm

**Narrow Beam/NB Model**

Filters	10 nm half-bandwidth interference filters. User-accessible filter wheel. Up to 5 filters may be installed on the instrument at one time. Filters supplied: 405, 450, 490, and 630 nm.
---------	---

<b>Prepared By :</b> Ms. Gopika S. L. <b>Designation:</b> Laboratory Technician (P-5410)	<b>Signature:</b> 	<b>Issue Date :</b> 09.07.2021	<b>Page No</b> 14
<b>Verified By :</b> Dr. Dinoop K. P. <b>Designation:</b> Assistant Professor, Microbiology	<b>Signature:</b> 	<b>Revision No:</b>	<b>Copy no:</b> Controlled
<b>Issued By :</b> Dr. Kavita Raja <b>Designation:</b> Professor & Head, Microbiology	<b>Signature :</b> 	<b>ICMR Extramural Adhoc: P-5410</b>	

**Department of Microbiology**  
**Sree Chitra Tirunal Institute for Medical Sciences and Technology (SCTIMST)**

*The following specifications apply to 96-well, flat- or round-bottom plates with a 50-second read (normal read mode).*



Absorbance Measurement Range	0.000 to 3.000 OD
Accuracy	$\pm 1.0\% \pm 0.010$ OD from 0.000 to 2.000 OD @ 405 nm
Linearity	$\pm 1.0\%$ from 0.000 to 2.000 OD @ 405 nm $\pm 3.0\%$ from 2.000 to 3.000 OD @ 450 nm
Repeatability (STD)	$\pm 0.5\% \pm 0.005$ OD from 0.000 to 2.000 OD @ 405 nm

*The following specifications apply to 96-well, flat- or round-bottom plates with a 30-second read (rapid read mode).*

Absorbance Measurement Range	0.000 to 3.000 OD
Accuracy	$\pm 2.0\% \pm 0.020$ OD from 0.000 to 2.000 OD @ 405 nm
Linearity	$\pm 2.0\%$ from 0.000 to 2.000 OD @ 405 nm
Repeatability (STD)	$\pm 1.0\% \pm 0.010$ OD from 0.000 to 2.000 OD @ 405 nm

*The following specifications apply to a 384-well plate. The minimum volume of fluid in a well to obtain the specified performance is 80 microliters. The specifications apply to the dual wavelength mode of read only.*

Absorbance Measurement Range	0.000 to 3.000 OD
<i>Normal Read Mode</i>	Dual wavelength (4 minutes, 45 seconds)
Accuracy	$\pm 2.0\% \pm 0.020$ OD from 0.000 to 2.000 OD @ 405 nm
Linearity	$\pm 2.5\%$ from 0.000 to 2.000 OD @ 405 nm
Repeatability (STD)	$\pm 1.5\% \pm 0.010$ OD from 0.000 to 2.000 OD @ 405 nm
<i>Rapid Read Mode</i>	Dual wavelength (3 minutes, 25 seconds)
Accuracy	$\pm 2.5\% \pm 0.020$ OD from 0.000 to 2.000 OD @ 405 nm
Linearity	$\pm 2.5\%$ from 0.000 to 2.000 OD @ 405 nm
Repeatability (STD)	$\pm 2.0\% \pm 0.010$ OD from 0.000 to 2.000 OD @ 405 nm

<b>Prepared By :</b> Ms. Gopika S. L. <b>Designation:</b> Laboratory Technician (P-5410)	<b>Signature:</b> 	<b>Issue Date :</b> 09.07.2021	<b>Page No</b> 15
<b>Verified By :</b> Dr. Dinoop K. P. <b>Designation:</b> Assistant Professor, Microbiology	<b>Signature:</b> 	<b>Revision No:</b>	<b>Copy no:</b> Controlled
<b>Issued By :</b> Dr. Kavita Raja <b>Designation:</b> Professor & Head, Microbiology	<b>Signature :</b> 	<b>ICMR Extramural Adhoc: P-5410</b>	

**Department of Microbiology**  
**Sree Chitra Tirunal Institute for Medical Sciences and Technology (SCTIMST)**

**Keypad and Main Menu**

The ELx800 features a keypad and 2-line x 24-character LCD display:

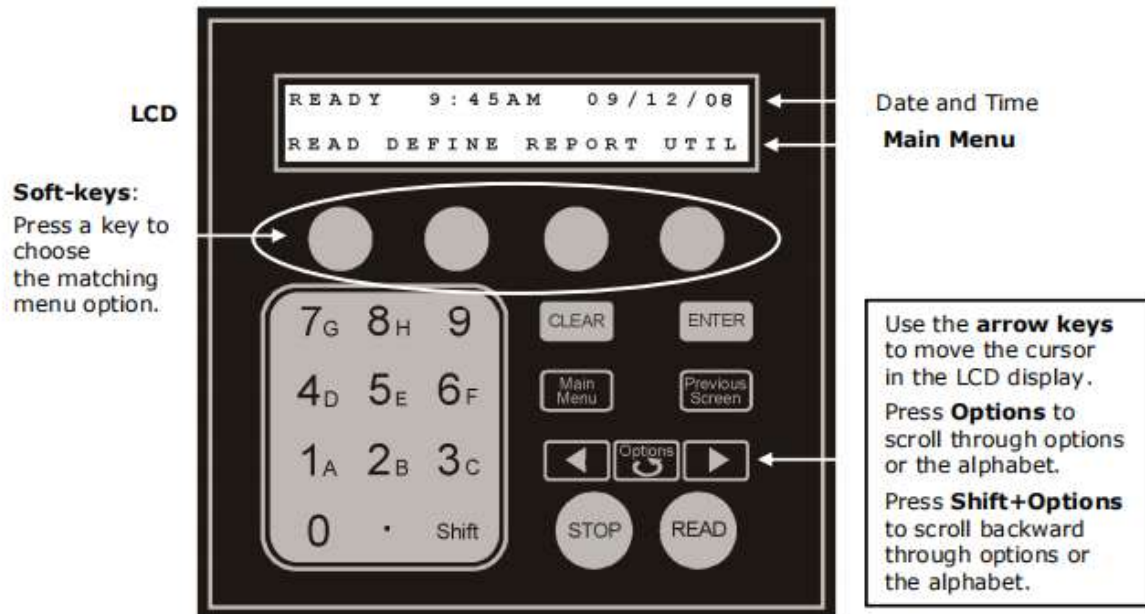

The Main Menu offers these options:

- **READ** (or, press the key labeled READ) to read a plate. You must select a preprogrammed assay or previously defined protocol.
- **DEFINE** to create or edit a reading and data reduction protocol. You will be prompted to select an existing assay. Assign a new name to create a new protocol or modify the parameters, as needed, to fine-tune the selected assay.
- **REPORT** to print stored protocol results; requires a previously run assay with valid data.
- **UTIL** to view or change settings or to run onboard utilities.

**Purpose of the Equipment:**

To run the Quick Read assay: **Presepsin**

1. Select **READ** at the main menu.
2. Select assay number **01\_Quick Read** and press Enter.

<b>Prepared By :</b> Ms. Gopika S. L. <b>Designation:</b> Laboratory Technician (P-5410)	<b>Signature:</b> 	<b>Issue Date :</b> 09.07.2021	<b>Page No</b> 16
<b>Verified By :</b> Dr. Dinoop K. P. <b>Designation:</b> Assistant Professor, Microbiology	<b>Signature:</b> 	<b>Revision No:</b>	<b>Copy no:</b> <b>Controlled</b>
<b>Issued By :</b> Dr. Kavita Raja <b>Designation:</b> Professor & Head, Microbiology	<b>Signature :</b> 	<b>ICMR Extramural Adhoc: P-5410</b>	

**Department of Microbiology**  
**Sree Chitra Tirunal Institute for Medical Sciences and Technology (SCTIMST)**

3. Choose Single wavelength 450nm
4. Select the measurement wavelength. For Dual readings, use the arrow key to move the cursor to the reference wavelength and select it. Press Enter.
5. If prompted, enter the number of samples on the plate and press Enter.
6. If prompted, enter a Plate ID and press Enter.
7. If prompted, enter a Sample ID and press Enter.
8. When the plate read is complete, **Generating Report Results** will display for a few moments and then the results report will print.



**Maintenance:**

**Routine Cleaning Procedure**

You will need a mild detergent, deionized or distilled water, and clean, lint-free cotton cloths.



1. Turn off and disconnect the instrument from the power supply.
2. Moisten a clean cotton cloth with water, or with water and the mild detergent.  
Do not soak the cloth.
3. Wipe the plate carrier and all exposed surfaces of the instrument.
4. If detergent was used, wipe all surfaces with a cloth moistened with water.
5. Use a clean, dry cloth to dry all wet surfaces.

**References:** ELx800™ Operator's Manual

<b>Prepared By :</b> Ms. Gopika S. L. <b>Designation:</b> Laboratory Technician (P-5410)	<b>Signature:</b> 	<b>Issue Date :</b> 09.07.2021	<b>Page No</b> 17
<b>Verified By :</b> Dr. Dinoop K. P. <b>Designation:</b> Assistant Professor, Microbiology	<b>Signature:</b> 	<b>Revision No:</b>	<b>Copy no:</b> Controlled
<b>Issued By :</b> Dr. Kavita Raja <b>Designation:</b> Professor & Head, Microbiology	<b>Signature :</b> 	<b>ICMR Extramural Adhoc: P-5410</b>	

Department of Microbiology  
Sree Chitra Tirunal Institute for Medical Sciences and Technology (SCTIMST)



<b>Prepared By :</b> Ms. Gopika S. L. <b>Designation:</b> Laboratory Technician (P-5410)	<b>Signature:</b> 	<b>Issue Date :</b> 09.07.2021	<b>Page No</b> 18
<b>Verified By :</b> Dr. Dinoop K. P. <b>Designation:</b> Assistant Professor, Microbiology	<b>Signature:</b> 	<b>Revision No:</b>	<b>Copy no:</b> Controlled
<b>Issued By :</b> Dr. Kavita Raja <b>Designation:</b> Professor & Head, Microbiology	<b>Signature :</b> 	<b>ICMR Extramural Adhoc: P-5410</b>	

### RESULTS (Final analysis)

During the 2-year period (October 2020-September 2022), a total of 578 CSF diversion catheters were inserted in 472 patients [240 (50.8 %) were females and 232 (49.2%) were males]. Of the 417 drains inserted, 211 were EVD catheters and 206 were LD catheters; and of the 161 shunts inserted, 133 were ventriculo-peritoneal (VP) shunts, 19 were lumbo-peritoneal (LP) shunts, 6 were subduro-peritoneal (SDP) shunts, 2 were syringo-subarachnoid (SS) shunt and 1 cysto-peritoneal (CP) shunt. The mean age at the time of insertion was 34.4 years. Hydrocephalus was the commonest indication for a shunt insertion (71.4 %), while tumour excision surgery was the commonest indication for a drain insertion (58.2%). The distribution of various CSF diversion catheter-related infections diagnosed based on the IDSA definition is shown in **Figure 1**.

Figure 1: CSF diversion catheter-related infection (CDRI) - IDSA criteria

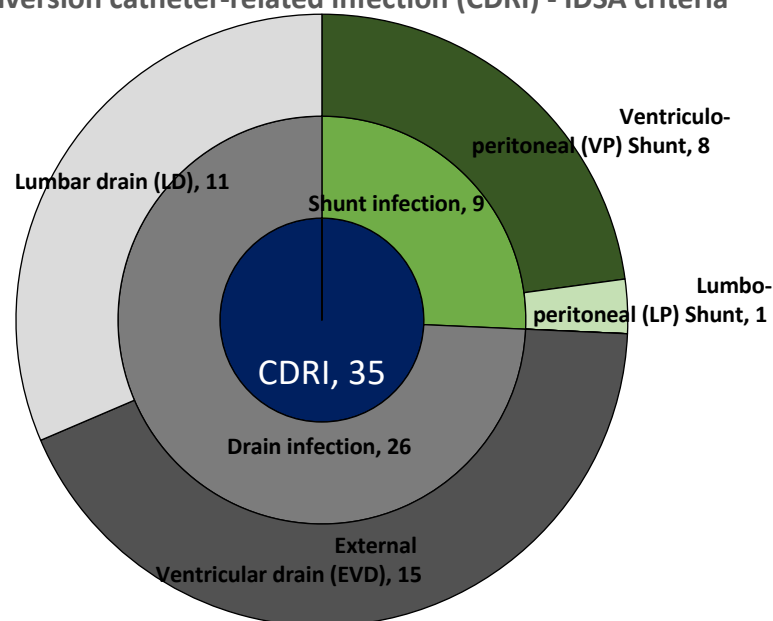

**Table 1:** Microbiological culture results of patients with CDRI (n=35)

CDRI: Oct20-Sep22	<i>S. aureus</i>	<i>S. epidermidis</i>	<i>Enterococcus faecalis</i>	<i>E. coli</i>	<i>K. pneumoniae</i>	<i>E. cloacae</i>	<i>A. baumannii</i>	<i>P.aeruginosa</i>	Culture negative	Total (n)
<b>Shunt infection</b>										<b>9</b>
VP Shunt	2	0	0	1	3	1	0	1	0	8
LP Shunt	0	0	0	0	1	0	0	0	0	1
<b>Drain infection</b>										<b>26</b>
EVD	1	1	1	0	6	0	4	2	0	15
LD	0	0	1	2	4	0	3	0	1	11
<b>Total</b>	<b>3</b>	<b>1</b>	<b>2</b>	<b>3</b>	<b>14</b>	<b>1</b>	<b>7</b>	<b>3</b>	<b>1</b>	<b>35</b>
Percentage (%)	8.6	2.9	5.7	8.6	40.0	2.9	20.0	8.6	2.9	100

In this analysis, Gram negative bacteria were the causative agents for CDRI in 28 cases (80%) while 6 cases (17%) were due to Gram positive bacteria and 1 case was culture negative (3%).

The most common organism causing drain, shunt and CSF diversion catheter-related infection (CDRI) [in total] was *Klebsiella pneumoniae* (n=14, 40%), followed by *Acinetobacter baumannii* (n=7, 20%). Among the Gram positive bacteria, *Staphylococcus aureus* was the commonest causative organism (n=3, 8.6%) mostly causing shunt infections, while *Enterococcus faecalis* [n=2, 5.7%] and Coagulase negative staphylococci (*S. epidermidis*) [n=1, 3%] mostly causing drain infections. There was 1 case of culture-negative CDRI/meningitis, probably due to fastidious or anaerobic bacteria like *Propionibacterium acne*.

The trend in the infection of various devices were analysed over the study period and is expressed as rate per procedure for CSF shunts (**Figure 2**) & rate per 1000 device days for CSF drains (**Figure**). The average rate for EVD infection during this 2-year period was 11.12 per 1000 EVD days, while for LD infection was 11.86 per 1000 LD days. The average infection rates for VP (**Figure**) and LP shunts (**Figure**) were 6 and 5.2 per procedure, respectively.

The individual device and cumulative rates (Drains and shunts) with trendline are shown in **Figures** - along with their reference tables.

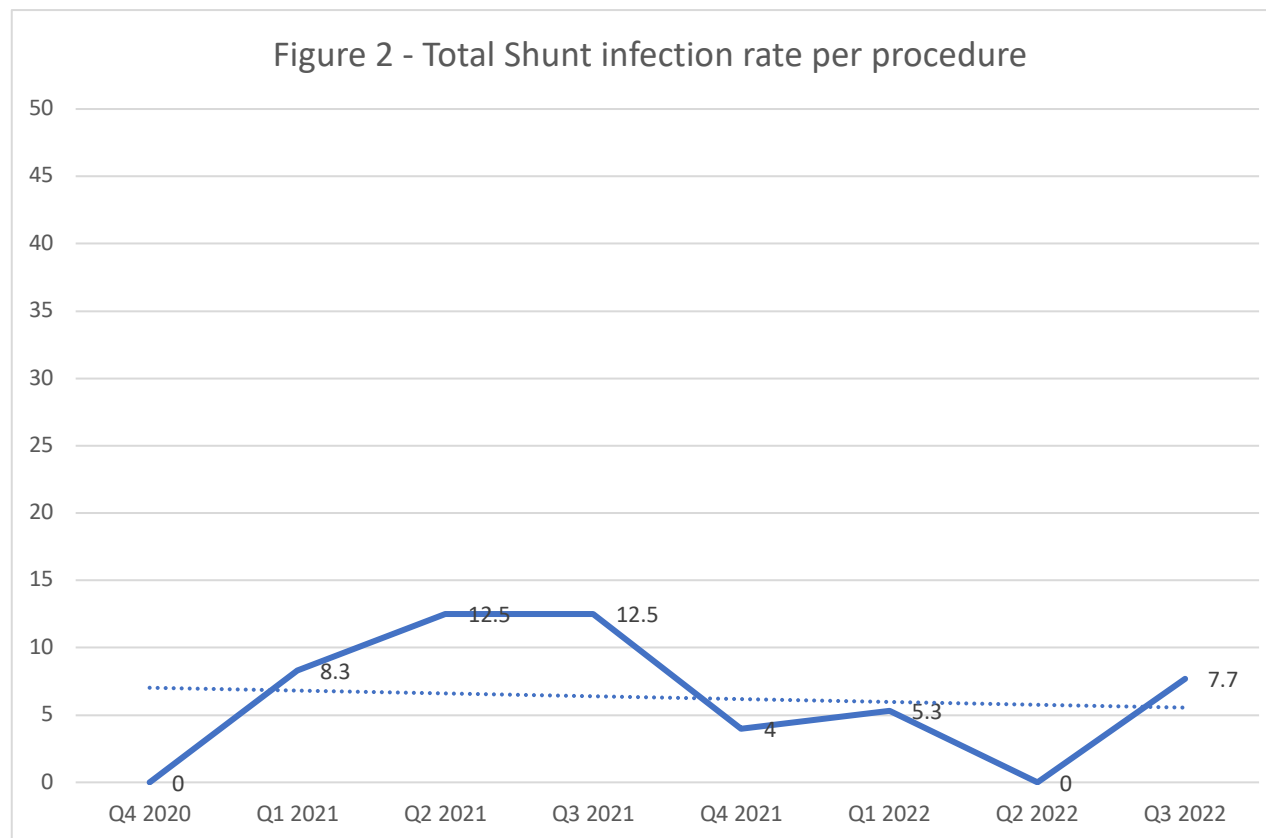

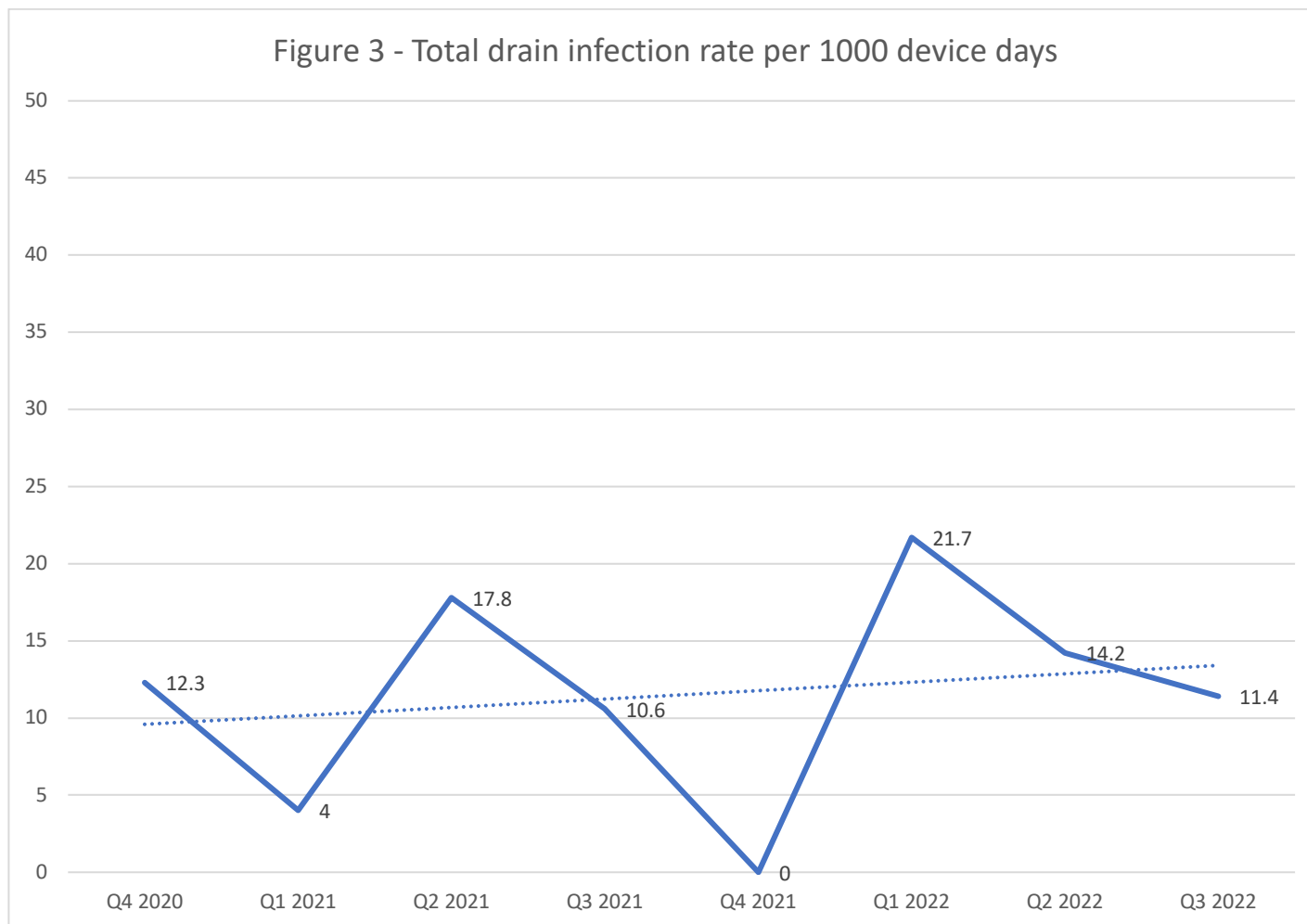

Quarter (Year)	EVD infection	EVD days	Rate per 1000 EVD days
Q4 2020	2	228	8.77
Q1 2021	1	121	8.26
Q2 2021	2	170	11.76
Q3 2021	2	151	13.25
Q4 2021	2	264	7.58
Q1 2022	0	116	0.00
Q2 2022	5	210	23.81
Q3 2022	1	88	11.36
TOTAL	15	1348	11.13

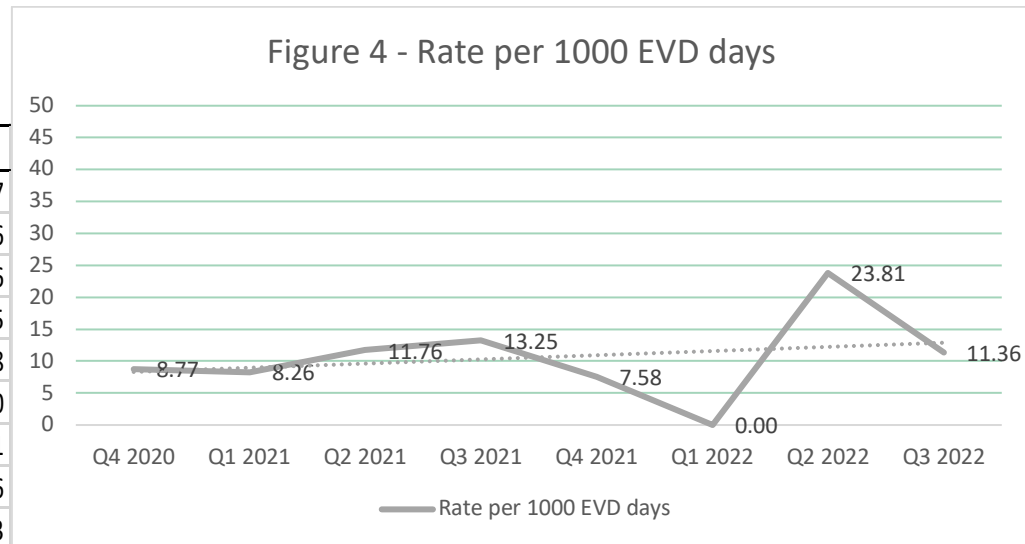

Quarter (Year)	LD infection	LD days	Rate per 1000 LD days
Q4 2020	2	99	20.2
Q1 2021	0	126	0.0
Q2 2021	3	111	27.0
Q3 2021	0	104	0.0
Q4 2021	2	113	17.7
Q1 2022	0	163	0.0
Q2 2022	3	158	19.0
Q3 2022	1	53	18.9
TOTAL	11	927	11.9

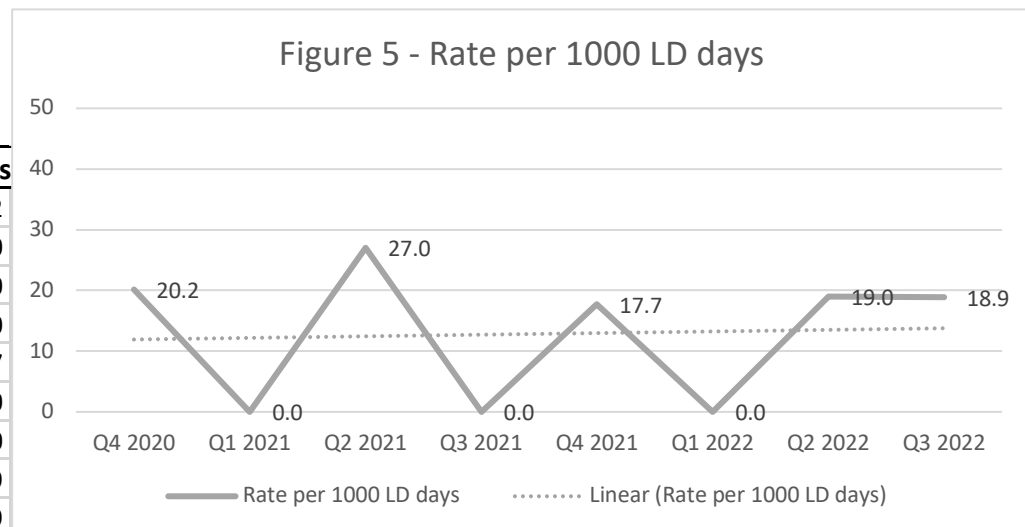

Quarter (Year)	VP shunt infection	Number of procedures	VP shunt Infection Rates per procedure
Q4 2020	0	19	0.00
Q1 2021	1	20	5.00
Q2 2021	2	15	13.33
Q3 2021	2	21	9.52
Q4 2021	1	23	4.35
Q1 2022	1	16	6.25
Q2 2022	0	10	0.00
Q3 2022	1	9	11.11
TOTAL	8	133	6.02

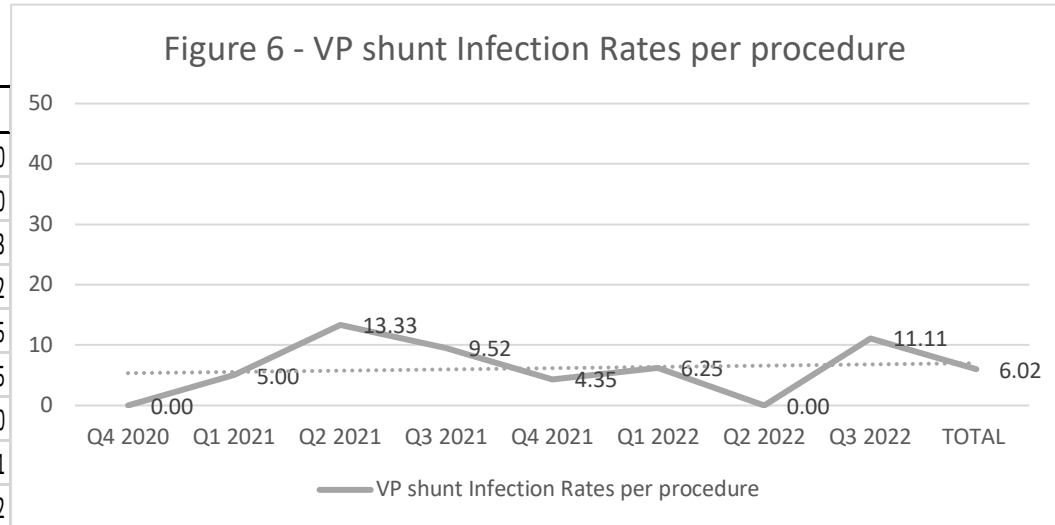

Quarter (Year)	LP shunt infection	Number of procedures	LP shunt Infection Rates per procedure
Q4 2020	0	6	0
Q1 2021	1	4	25
Q2 2021	0	0	0
Q3 2021	0	2	0
Q4 2021	0	2	0
Q1 2022	0	1	0
Q2 2022	0	1	0
Q3 2022	0	3	0
TOTAL	1	19	5.263157895

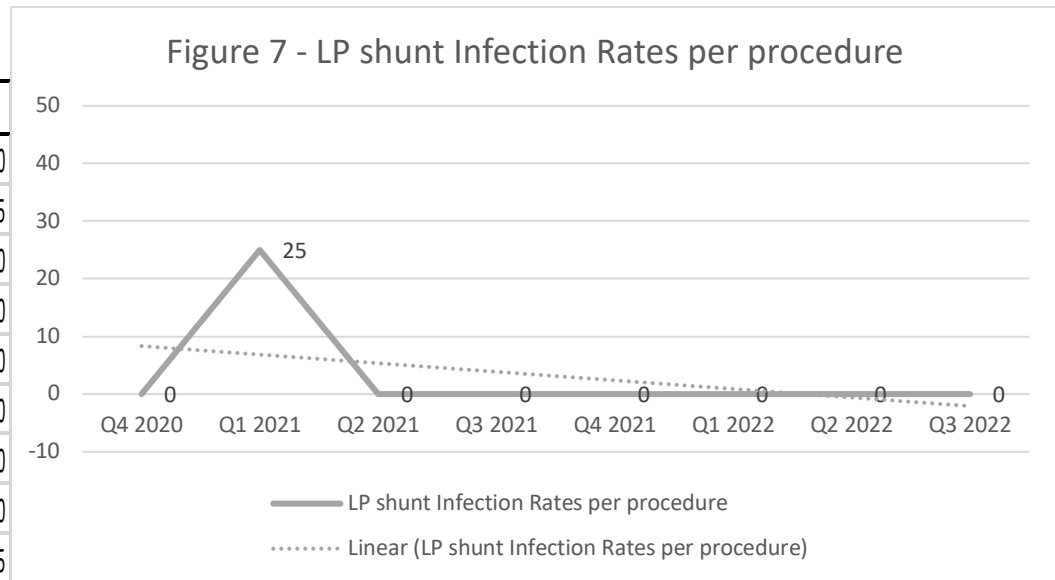

**Statistical analysis:** Addinsoft (2022); XLSTAT statistical and Life Sciences data analysis solution, version 2022.4.1; New York, USA

- **Fischer's exact test:** Comparison of qualitative variables using between infected (CDRI) & non-infected cases (qualitative outcome)

Variables which had association or significance [p value < alpha (0.05)] with CSF diversion catheter-related infections (CDRI) were

1. Post-operative CSF leak (p<0.0001) [Observed in 31.6% of patients with CDRI]
2. Associated Scalp SSTI (p<0.0001) [Observed in 20.6% of patients with CDRI]
3. Associated Systemic infection (p<0.0001) [Observed in 20% of Patients with CDRI]
4. Presence of external ventricular drain (EVD)/ lumbar drain (LD) leak (p=0.01) [Observed in 9.7% of patients with CDRI]
5. 30-day mortality (p=0.017)
6. 30-day Modified Rankin scale (p<0.0001)

No significant association was found for the following variables

1. Elective vs Emergency device insertion procedure [p=0.438]
2. Type of device (Shunt vs drain) [p=0.847]
3. Type of shunts and drains (subgroup analysis) [p=0.898 and 0.99 respectively]
4. Presence of CSF leak prior to surgical procedure [p=0.438]
5. Gender [p=0.268]

Duration of CSF drain had positive association (Coefficient: 0.063, 95% CI: 0.022-0.104, p=0.003) with development of drain infection while reduced CSF sampling was negatively associated (Coefficient:-1.776, 95% CI: -3.398 to -0.154, p=0.032) with development of new

drain-associated infection. Posterior approaches within the occipital area chosen as point of insertion for shunts or drains was associated with increased risk of CDRI (Coefficient: 2.752, 95% CI: 0.470-5.033, p=0.018).

New onset of fever (Coefficient: 2.987, 95% CI: 2.128-3.845, p<0.0001), along with neck stiffness (Coefficient: 3.604, 95% CI: 2.169-5.040, p<0.0001) and deterioration from the baseline mental status (Coefficient: 2.939, 95% CI: 1.824-4.053, p<0.0001) were positively associated in prediction of drain-associated infection while malaise (Coefficient: 2.768, 95% CI: 1.888-3.647, p<0.0001), nausea (Coefficient: 2.689, 95% CI: 1.447-3.932, p<0.0001) and headache (Coefficient: 2.576, 95% CI: 1.538-3.614, p<0.0001) along with the new onset of fever were positively associated in prediction of shunt-associated infection. **(Table 2)**

**Table 2: Logistic regression analysis:** Results of comparison of single quantitative variable/ multiple independent variables with a qualitative outcome) to calculate the odds ratio and the significance of the association.

Parameters	Odds ratio	95% CI (Odds Ratio)	Coefficient	p value
Age	1.00	0.98-1.02	0.001	0.87
Prophylactic antibiotic				
Amikacin-ceftriaxone	Ref			
Cefuroxime	2.17	0.64-7.32	0.777	0.21
Amikacin-meropenem	3.48	0.32-37.02	1.247	0.30
Pre-OP ASA score (ASA-4)	1.43	0.75-2.71	0.359	0.27
Indication for surgery				
Duration of surgery	1.00	0.998-1.002	0.00	0.93
Operating surgeon' experience	1.05	0.335-3.302	0.05	0.93

Intracranial pressure (Mod-High)	-	-	15.56	0.99
Type of shunt	0.83	0.09-7.00	-0.188	0.86
<b>Point of shunt insertion (Posterior approach - Occipital)</b>	<b>15.66</b>	<b>1.60-153.34</b>	<b>2.752</b>	<b>0.018</b>
Type of drain	1.24	0.16-9.67	0.218	0.835
<b>Duration of drain</b>	<b>1.065</b>	<b>1.022-1.110</b>	<b>0.063</b>	<b>0.003</b>
<b>CSF sampling frequency (Only when clinically indicated)</b>	<b>0.169</b>	<b>0.033-0.857</b>	<b>-1.776</b>	<b>0.032</b>
<b>New onset of fever</b>	<b>19.822</b>	<b>8.39-46.78</b>	<b>2.987</b>	<b>&lt;0.0001</b>
<b>Malaise</b>	<b>15.919</b>	<b>6.61-38.34</b>	<b>2.768</b>	<b>&lt;0.0001</b>
<b>Deterioration in mental status</b>	<b>18.893</b>	<b>6.19-57.58</b>	<b>2.939</b>	<b>&lt;0.0001</b>
<b>Headache</b>	<b>13.15</b>	<b>4.65-37.13</b>	<b>2.576</b>	<b>&lt;0.0001</b>
<b>Neck stiffness</b>	<b>36.75</b>	<b>8.74-154.43</b>	<b>3.60</b>	<b>&lt;0.0001</b>
<b>Nausea</b>	<b>14.72</b>	<b>4.25-51.00</b>	<b>2.68</b>	<b>&lt;0.0001</b>

Insertion of drain (EVD/lumbar) had 12 times higher risk of device associated CNS infection [HR:11.73, 95% CI: 3.53 - 38.96, p value - 0.03] while posterior approach of EVD insertion (occipital) and presence of high pre-OP ASA score had 10 [HR:9.53, 95% CI: 1.54 - 59.05, p value - 0.01] and 8 times [HR:8.28, 95% CI: 1.56 - 43.83, p value - 0.013] higher risk of device-associated infection respectively. The other risk variables which were found close to statistical significance are shown in the figure (Table 3).

**Table 3: Hazard risk for CDRI using Cox regression model (accounting adjustment with other variables)**

<b>Parameters</b>	<b>Hazard ratio</b>	<b>95% CI</b>	<b>Coefficient</b>	<b>p value</b>
Pre-OP ASA (Shunt infection)	8.28	1.56-43.83	2.115	0.013
Shift to pre-surgical prophylactic antibiotic cefuroxime	3.61	-1.486-2.017	-1.284	0.03
Drain insertion	11.73	3.53-38.96	2.46	<0.0001
Lumbar drain	2.63	1.02-6.80	0.969	0.04
Point of EVD insertion (Posterior approach - Occipital)	9.53	1.54-59.05	2.25	0.01
Associated systemic infection (Peri- OP)	3.890	1.39-10.86	1.358	0.01
Associated Scalp SSTI (Peri-OP)	3.531	1.468-8.493	1.262	0.005
EVD/LD leak	17.24	4.83-61.49	2.847	<0.0001
CSF sampling frequency (Only when clinically indicated)	0.175	0.00-0.75	-1.741	0.02
Male gender	2.05	0.99-4.21	0.718	0.05
Surgery Indication - Hydrocephalus	0.08	0.0-0.9	-2.431	0.04
Duration of surgery	1.00	1.000-1.004	0.002	0.02

**2-sample t-test (Student' t-test):** Comparison of qualitative independent variables with quantitative outcome variables. These are expressed as box and whisker plots with corresponding mean and standard deviation. The mean duration of ICU and hospital stay between CDRI and non-infected group were 14 days vs 6.5 days and 32.7 days vs 20.8 days, respectively (**Figure 8 & 9**)

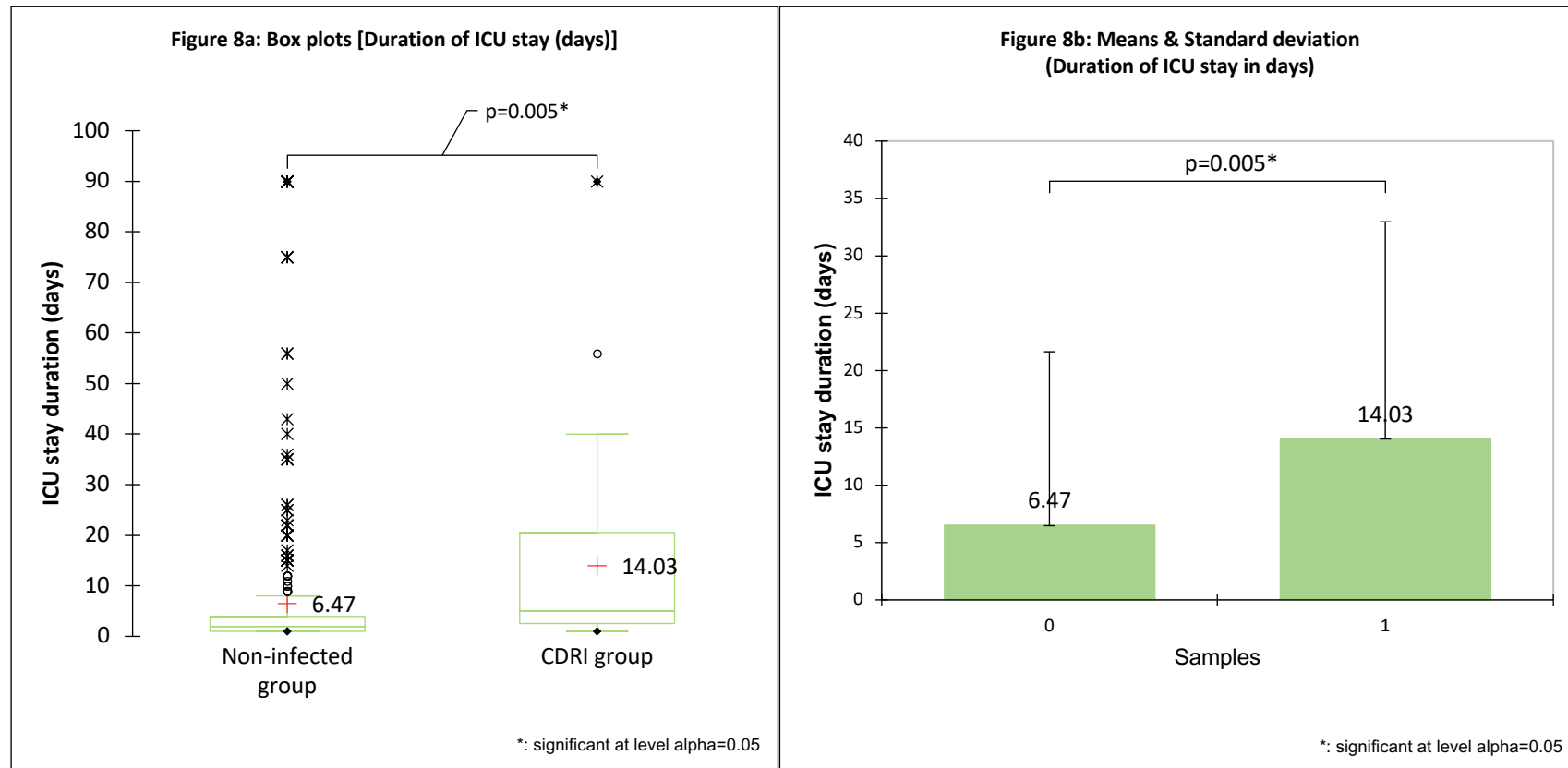

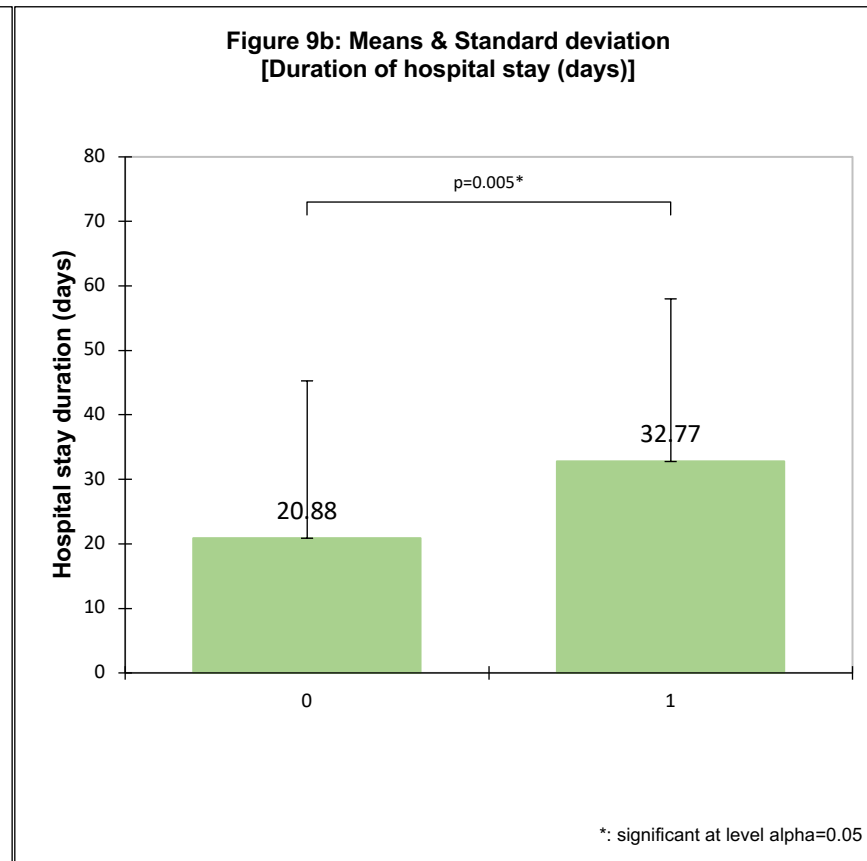
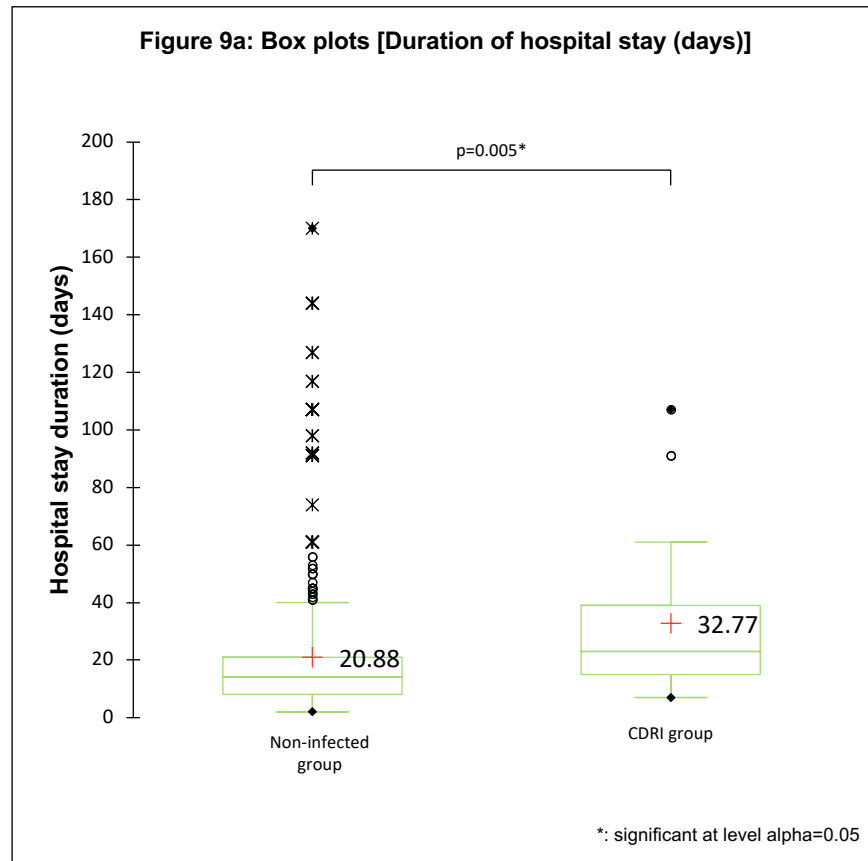

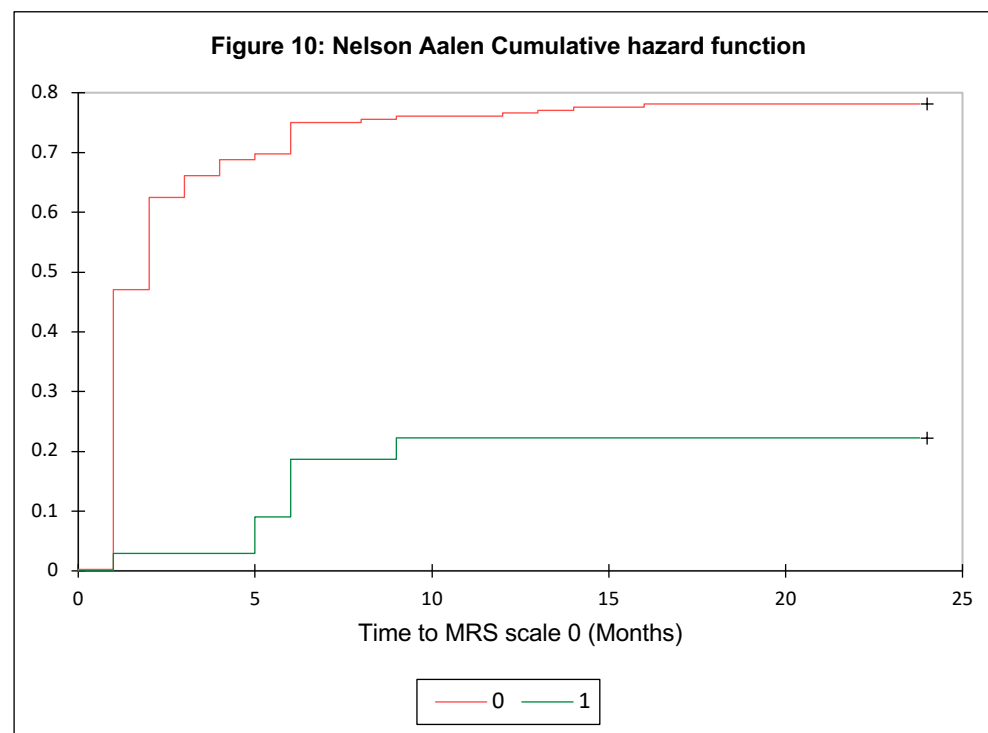

Test of equality of the survival distribution functions (DF = 1):				
Statistic	Observed value	Critical value	p-value	alpha
Log-rank	19.812	3.841	<0.0001	0.050
Wilcoxon	26.516	3.841	<0.0001	0.050
Tarone-Ware	23.980	3.841	<0.0001	0.050

The Nelson-Aalen cumulative hazard estimate was performed to compare time taken to progress to modified Rankin scale 0 (No symptoms/disability) between CDRI & non-infected groups. Statistical significance ( $p < 0.0001$ ) was observed in log-rank equality test between the 2 groups (**Figure 10**)

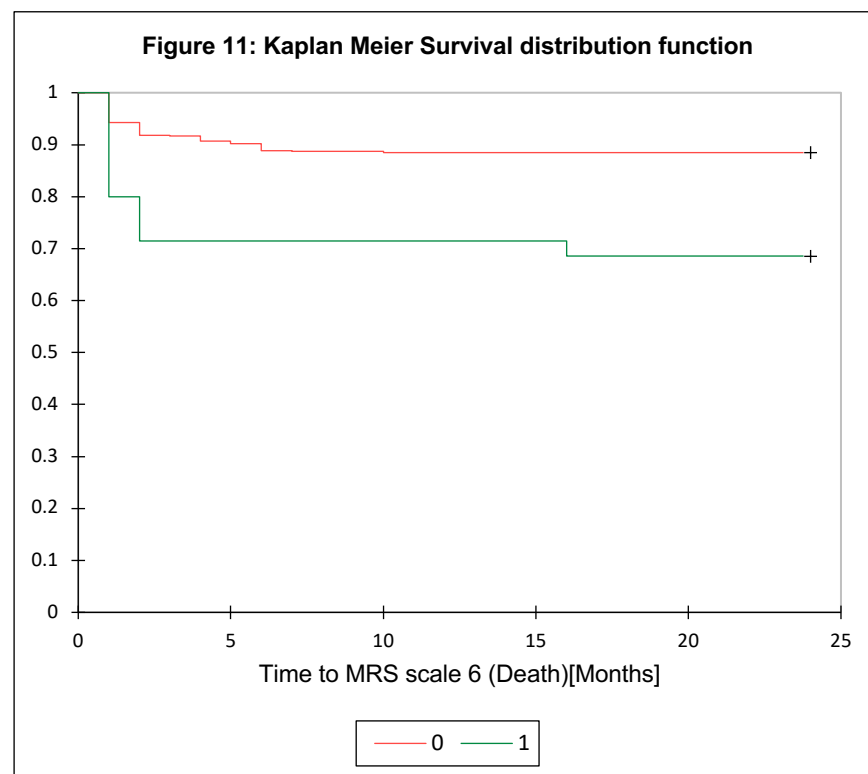

Test of equality of the survival distribution functions (DF = 1):				
Statistic	Observed value	Critical value	p-value	alpha
Log-rank	12.965	3.841	0.000	0.050
Wilcoxon	13.335	3.841	0.000	0.050
Tarone-Ware	13.159	3.841	0.000	0.050

Kaplan-Meier survival analysis to compare time taken to progress to Modified Rankin scale 6 (Death) between the 2 groups was statistically significant ( $p < 0.0001$ ) in the final analysis of a follow-up period of 24 months (**Figure 11**)

### Laboratory biomarkers (Final analysis report)

Box and whisker plot analysis shows the comparison in the mean, median, standard deviation and upper/lower limits of the biomarker levels between the CDRI and the non-infected group.

Receiver Operating Characteristic (ROC) curve analysis was performed for evaluation of the novel CSF biomarkers in diagnosis of CSF diversion catheter related infections (CDRI).

ROC curve analysis shows the Area under the curve (AUC) with statistical significance for the difference seen between the 2 groups.

The determination of the optimal cut-off concentration of the biomarker (**Marked bold**) with the highest sensitivity, specificity, positive & negative predictive values with accuracy to detect CDRI are shown in the table below the ROC curve.

S. No	Parameters	Mean	Inter-quartile range (IQR)	Receiver Operating Characteristic (ROC) curve analysis							
				Optimal cut-off Concentration	Sensitivity	Specificity	PPV	NPV	Accuracy	AUC	p value
1.	CSF Procalcitonin (ng/ml)	1.43	0.186-1.011	0.084	93.8	80.0	90.9	85.7	89.4	0.902	<0.0001
2.	CSF Presepsin (pg/ml)	3020.92	623-5007	922	59.4	93.3	95	51.9	70.2	0.784	<0.0001
3.	CSF Lactate (mmol/L)	13.19	7.7-18.1	4.1	93.9	93.3	96.9	87.5	93.8	0.972	<0.0001
4.	CSF IL-1Beta (pg/ml)	427.91	0.77-67.97	0.270	87.5	92.3	96.6	75.0	88.9	0.897	<0.0001
5.	CSF IL-17A (pg/ml)	97.81	7.52-39.08	5.25	87.5	84.6	93.3	73.3	86.7	0.901	<0.0001
5.	Serum Procalcitonin (ng/ml)	7.8	0.16-10.81	0.26	66.7	90.0	95.7	45.0	72.1	0.791	<0.0001

There was no statistical significance observed in using CSF IL-1beta ( $p = 0.726$ ) or CSF IL-17A ( $p = 0.971$ ) in differentiating Gram-positive vs Gram-negative CSF diversion catheter-related infections (CDRI).

**CSF procalcitonin**  
**Comparison of cPCT levels between CDRI vs non-infected group**

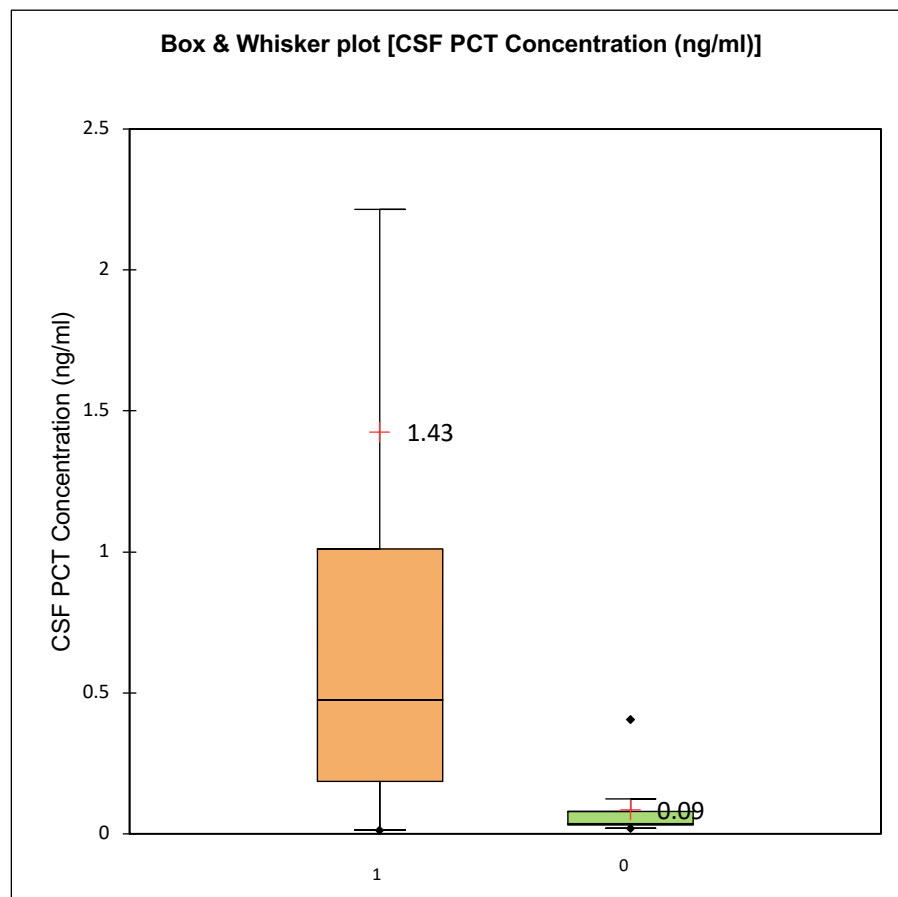

Statistic	CDRI group	Non-infected
Nbr. of observations	35	15
Minimum	0.014	0.020
Maximum	18.840	0.406
1st Quartile	0.186	0.031
Median	0.474	0.037
3rd Quartile	1.011	0.079
Mean	1.426	0.086
Variance (n-1)	11.384	0.012
Standard deviation (n-1)	3.374	0.111

Receiver-operating characteristic (ROC) curve analysis (CSF-PCT)

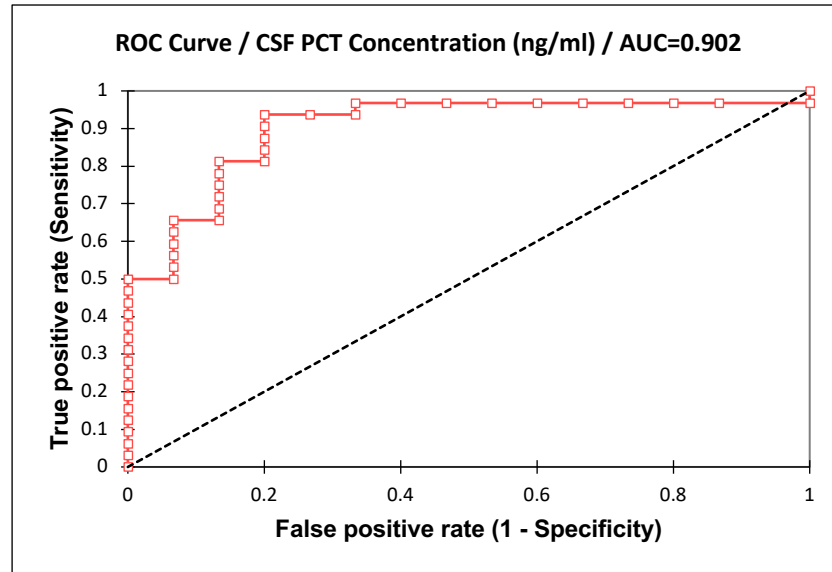

Area under the curve (AUC):				Difference	0.402
				z (Observed value)	8.348
				z (Critical value)	2.645
AUC	Standard error	Lower bound (95%)	Upper bound (95%)	p-value (one-tailed)	< 0.0001
0.902	0.048	0.808	0.996	alpha	0.05

PCT Concentration (ng/ml)	Sensitivity	Lower bound (95%)	Upper bound (95%)	Specificity	Lower bound (95%)	Upper bound (95%)	PPV	NPV	LR+	LR-	TP	TN	FP	FN	Sensitivity+Specificity	Accuracy
0.014	0.969	0.820	0.998	0.000	0.006	0.253	0.674	0.000	0.969	+Inf	31	0	15	1	0.969	0.660
0.020	0.969	0.820	0.998	0.133	0.023	0.416	0.705	0.667	1.118	0.234	31	2	13	1	1.102	0.702
0.024	0.969	0.820	0.998	0.200	0.053	0.486	0.721	0.750	1.211	0.156	31	3	12	1	1.169	0.723
0.031	0.969	0.820	0.998	0.267	0.089	0.552	0.738	0.800	1.321	0.117	31	4	11	1	1.235	0.745
0.032	0.969	0.820	0.998	0.333	0.130	0.613	0.756	0.833	1.453	0.094	31	5	10	1	1.302	0.766
0.033	0.969	0.820	0.998	0.400	0.175	0.671	0.775	0.857	1.615	0.078	31	6	9	1	1.369	0.787
0.036	0.969	0.820	0.998	0.467	0.223	0.726	0.795	0.875	1.816	0.067	31	7	8	1	1.435	0.809
0.037	0.969	0.820	0.998	0.533	0.274	0.777	0.816	0.889	2.076	0.059	31	8	7	1	1.502	0.830
0.041	0.969	0.820	0.998	0.600	0.329	0.825	0.838	0.900	2.422	0.052	31	9	6	1	1.569	0.851
0.051	0.969	0.820	0.998	0.667	0.387	0.870	0.861	0.909	2.906	0.047	31	10	5	1	1.635	0.872
0.061	0.938	0.778	0.989	0.667	0.387	0.870	0.857	0.833	2.813	0.094	30	10	5	2	1.604	0.851
0.075	0.938	0.778	0.989	0.733	0.448	0.911	0.882	0.846	3.516	0.085	30	11	4	2	1.671	0.872
<b>0.084</b>	<b>0.938</b>	<b>0.778</b>	<b>0.989</b>	<b>0.800</b>	<b>0.514</b>	<b>0.947</b>	<b>0.909</b>	<b>0.857</b>	<b>4.688</b>	<b>0.078</b>	<b>30</b>	<b>12</b>	<b>3</b>	<b>2</b>	<b>1.738</b>	<b>0.894</b>
0.086	0.906	0.738	0.975	0.800	0.514	0.947	0.906	0.800	4.531	0.117	29	12	3	3	1.706	0.872
0.090	0.875	0.701	0.959	0.800	0.514	0.947	0.903	0.750	4.375	0.156	28	12	3	4	1.675	0.851
0.101	0.844	0.665	0.941	0.800	0.514	0.947	0.900	0.706	4.219	0.195	27	12	3	5	1.644	0.830

**CSF Presepsin (PSP)**  
**Comparison of cPSP levels between CDRI vs non-infected group**

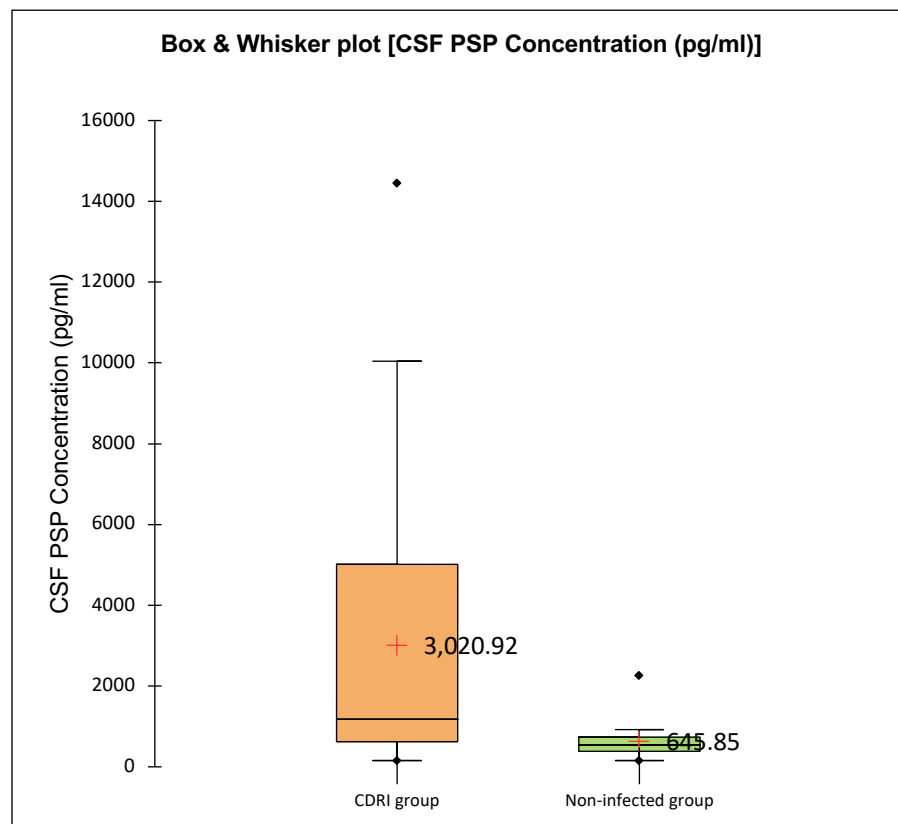

Statistic	CDRI group	Non-infected
Nbr. of observations	35	15
Minimum	156.000	156.000
Maximum	14463.000	2278.000
1st Quartile	623.028	381.720
Median	1171.420	549.000
3rd Quartile	5007.250	740.695
Mean	3020.925	645.853
Variance (n-1)	13107100.308	249436.784
Standard deviation (n-1)	3620.373	499.436

Receiver-operating characteristic (ROC) curve analysis (CSF Presepsin - cPSP)

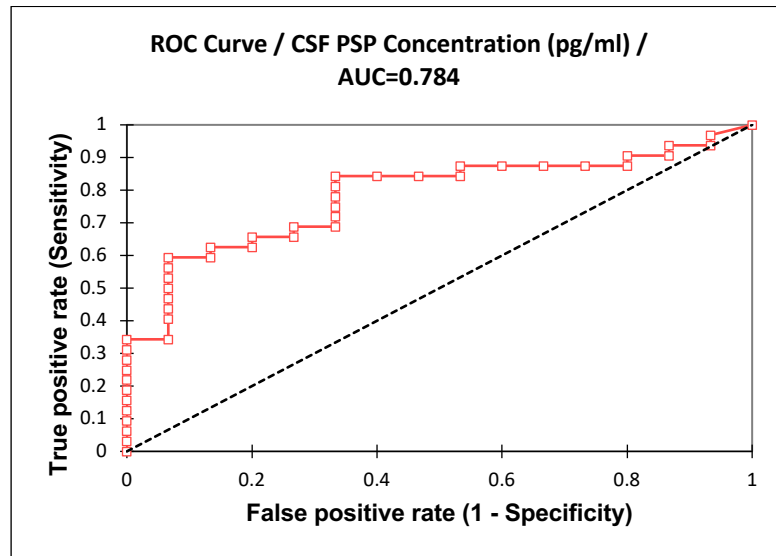

Area under the curve (AUC):			
AUC	Standard error	Lower bound (95%)	Upper bound (95%)
0.784	0.067	0.653	0.916

Difference	0.284
z (Observed value)	4.227
z (Critical value)	2.645
p-value (one-tailed)	< 0.0001
alpha	0.05

PSP Concentration (pg/ml)	Sensitivity	Lower bound (95%)	Upper bound (95%)	Specificity	Lower bound (95%)	Upper bound (95%)	PPV	NPV	LR+	LR-	TP	TN	FP	FN	itivity+Specif	Accuracy
156.000	0.969	0.820	0.998	0.067	0.003	0.340	0.689	0.500	1.038	0.469	31	1	14	1	1.035	0.681
165.000	0.938	0.778	0.989	0.067	0.003	0.340	0.682	0.333	1.004	0.938	30	1	14	2	1.004	0.660
288.000	0.938	0.778	0.989	0.133	0.023	0.416	0.698	0.500	1.082	0.469	30	2	13	2	1.071	0.681
288.890	0.906	0.738	0.975	0.133	0.023	0.416	0.690	0.400	1.046	0.703	29	2	13	3	1.040	0.660
314.000	0.906	0.738	0.975	0.200	0.053	0.486	0.707	0.500	1.133	0.469	29	3	12	3	1.106	0.681
371.990	0.875	0.701	0.959	0.200	0.053	0.486	0.700	0.429	1.094	0.625	28	3	12	4	1.075	0.660
375.470	0.875	0.701	0.959	0.267	0.089	0.552	0.718	0.500	1.193	0.469	28	4	11	4	1.142	0.681
387.970	0.875	0.701	0.959	0.333	0.130	0.613	0.737	0.556	1.313	0.375	28	5	10	4	1.208	0.702
483.000	0.875	0.701	0.959	0.400	0.175	0.671	0.757	0.600	1.458	0.313	28	6	9	4	1.275	0.723
505.000	0.875	0.701	0.959	0.467	0.223	0.726	0.778	0.636	1.641	0.268	28	7	8	4	1.342	0.745
541.000	0.844	0.665	0.941	0.467	0.223	0.726	0.771	0.583	1.582	0.335	27	7	8	5	1.310	0.723
549.000	0.844	0.665	0.941	0.533	0.274	0.777	0.794	0.615	1.808	0.293	27	8	7	5	1.377	0.745
550.000	0.844	0.665	0.941	0.600	0.329	0.825	0.818	0.643	2.109	0.260	27	9	6	5	1.444	0.766
552.960	0.844	0.665	0.941	0.667	0.387	0.870	0.844	0.667	2.531	0.234	27	10	5	5	1.510	0.787
557.000	0.813	0.630	0.921	0.667	0.387	0.870	0.839	0.625	2.438	0.281	26	10	5	6	1.479	0.766
596.200	0.781	0.596	0.901	0.667	0.387	0.870	0.833	0.588	2.344	0.328	25	10	5	7	1.448	0.745
606.400	0.750	0.562	0.879	0.667	0.387	0.870	0.828	0.556	2.250	0.375	24	10	5	8	1.417	0.723
628.570	0.719	0.530	0.856	0.667	0.387	0.870	0.821	0.526	2.156	0.422	23	10	5	9	1.385	0.702
648.480	0.688	0.499	0.833	0.667	0.387	0.870	0.815	0.500	2.063	0.469	22	10	5	10	1.354	0.681
702.000	0.688	0.499	0.833	0.733	0.448	0.911	0.846	0.524	2.578	0.426	22	11	4	10	1.421	0.702
733.690	0.656	0.468	0.808	0.733	0.448	0.911	0.840	0.500	2.461	0.469	21	11	4	11	1.390	0.681
779.390	0.656	0.468	0.808	0.800	0.514	0.947	0.875	0.522	3.281	0.430	21	12	3	11	1.456	0.702
786.730	0.625	0.437	0.783	0.800	0.514	0.947	0.870	0.500	3.125	0.469	20	12	3	12	1.425	0.681
845.000	0.625	0.437	0.783	0.867	0.584	0.977	0.909	0.520	4.688	0.433	20	13	2	12	1.492	0.702
909.990	0.594	0.408	0.758	0.867	0.584	0.977	0.905	0.500	4.453	0.469	19	13	2	13	1.460	0.681
<b>922.000</b>	<b>0.594</b>	<b>0.408</b>	<b>0.758</b>	<b>0.933</b>	<b>0.660</b>	<b>0.997</b>	<b>0.950</b>	<b>0.519</b>	<b>8.906</b>	<b>0.435</b>	<b>19</b>	<b>14</b>	<b>1</b>	<b>13</b>	<b>1.527</b>	<b>0.702</b>
987.900	0.563	0.379	0.732	0.933	0.660	0.997	0.947	0.500	8.438	0.469	18	14	1	14	1.496	0.681
1081.200	0.531	0.350	0.705	0.933	0.660	0.997	0.944	0.483	7.969	0.502	17	14	1	15	1.465	0.660

**CSF Lactate (cLac)**  
**Comparison of cLac levels between CDRI vs non-infected group**

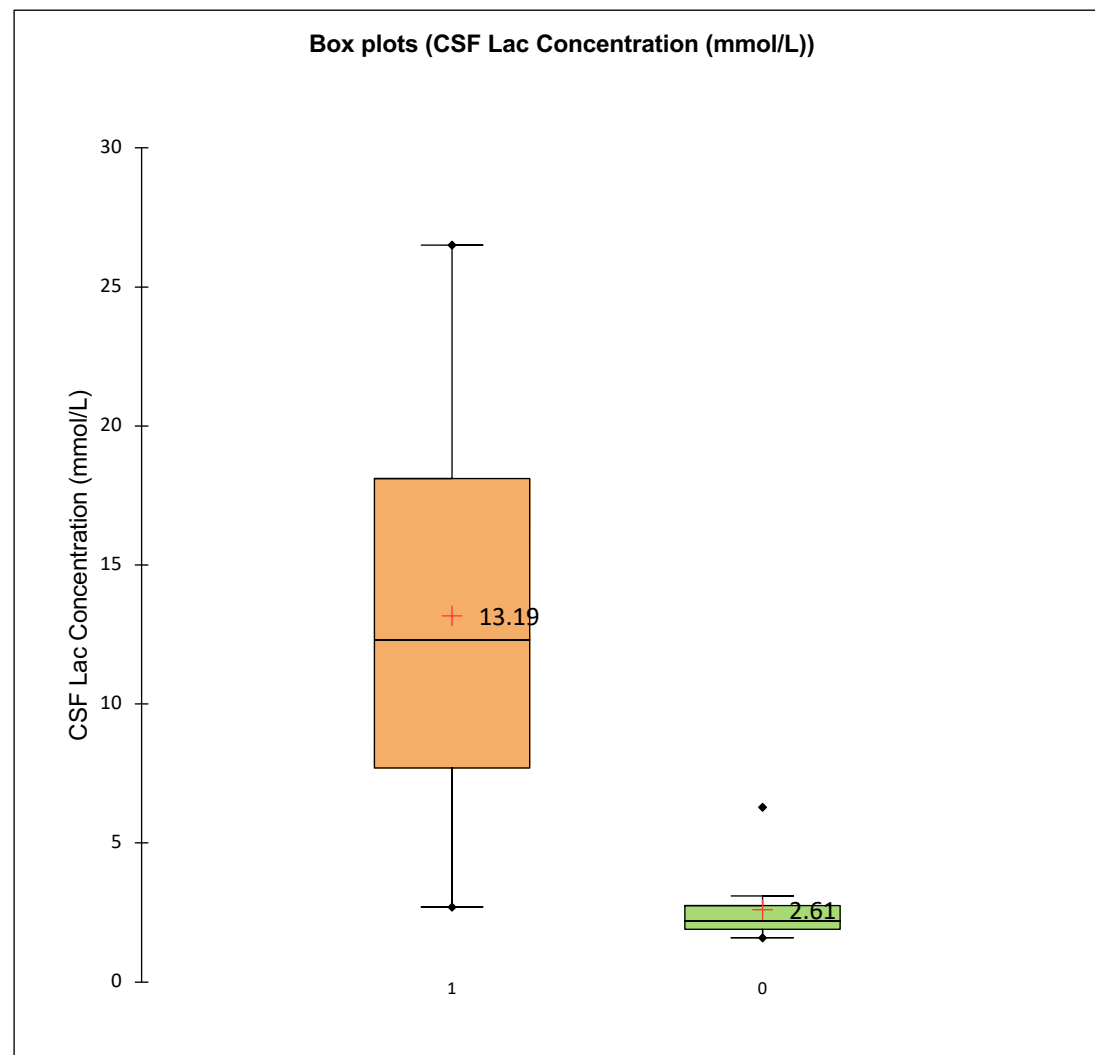

Statistic	CDRI group	Non-infected
Nbr. of observations	35	15
Minimum	2.700	1.600
Maximum	26.500	6.300
1st Quartile	7.700	1.900
Median	12.300	2.200
3rd Quartile	18.100	2.750
Mean	13.188	2.613
Variance (n-1)	46.613	1.453
Standard deviation (n-1)	6.827	1.205

Receiver-operating characteristic (ROC) curve analysis (CSF Lactate - cLac)

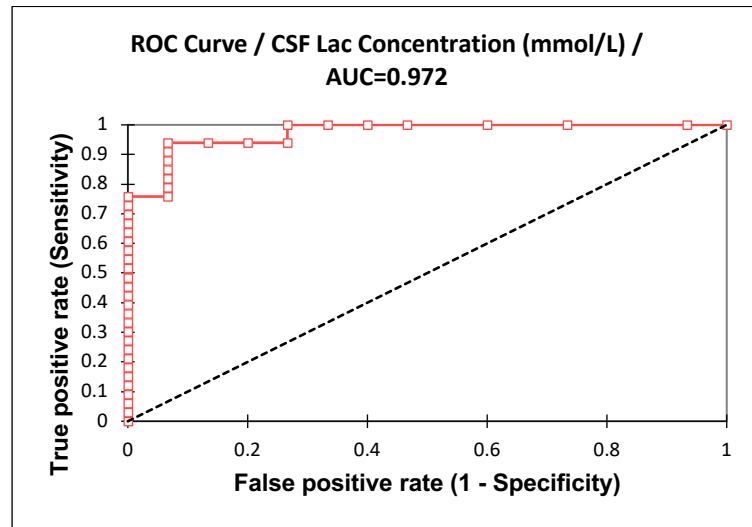

Area under the curve (AUC):			
AUC	Standard error	Lower bound (95%)	Upper bound (95%)
0.972	0.019	0.934	1.000

Difference	0.472
z (Observed value)	24.623
z (Critical value)	2.645
p-value (one-tailed)	< 0.0001
alpha	0.05

CSF Lac Conc	Sensitivity	Lower bound (95%)	Upper bound (95%)	Specificity	Lower bound (95%)	Upper bound (95%)	PPV	NPV	LR+	LR-	TP	TN	FP	FN	Sensitivity+Specificity	Accuracy
1.600	1.000	0.870	0.997	0.067	0.003	0.340	0.702	1.000	1.071	0.000	33	1	14	0	1.067	0.708
1.800	1.000	0.870	0.997	0.267	0.089	0.552	0.750	1.000	1.364	0.000	33	4	11	0	1.267	0.771
2.000	1.000	0.870	0.997	0.400	0.175	0.671	0.786	1.000	1.667	0.000	33	6	9	0	1.400	0.813
2.200	1.000	0.870	0.997	0.533	0.274	0.777	0.825	1.000	2.143	0.000	33	8	7	0	1.533	0.854
2.300	1.000	0.870	0.997	0.600	0.329	0.825	0.846	1.000	2.500	0.000	33	9	6	0	1.600	0.875
2.500	1.000	0.870	0.997	0.667	0.387	0.870	0.868	1.000	3.000	0.000	33	10	5	0	1.667	0.896
2.600	1.000	0.870	0.997	0.733	0.448	0.911	0.892	1.000	3.750	0.000	33	11	4	0	1.733	0.917
2.700	0.939	0.784	0.989	0.733	0.448	0.911	0.886	0.846	3.523	0.083	31	11	4	2	1.673	0.875
2.900	0.939	0.784	0.989	0.800	0.514	0.947	0.912	0.857	4.697	0.076	31	12	3	2	1.739	0.896
3.100	0.939	0.784	0.989	0.867	0.584	0.977	0.939	0.867	7.045	0.070	31	13	2	2	1.806	0.917
<b>4.100</b>	<b>0.939</b>	<b>0.784</b>	<b>0.989</b>	<b>0.933</b>	<b>0.660</b>	<b>0.997</b>	<b>0.969</b>	<b>0.875</b>	<b>14.091</b>	<b>0.065</b>	<b>31</b>	<b>14</b>	<b>1</b>	<b>2</b>	<b>1.873</b>	<b>0.938</b>
4.700	0.909	0.745	0.976	0.933	0.660	0.997	0.968	0.824	13.636	0.097	30	14	1	3	1.842	0.917
5.200	0.879	0.709	0.960	0.933	0.660	0.997	0.967	0.778	13.182	0.130	29	14	1	4	1.812	0.896
5.600	0.848	0.673	0.943	0.933	0.660	0.997	0.966	0.737	12.727	0.162	28	14	1	5	1.782	0.875
6.000	0.818	0.639	0.924	0.933	0.660	0.997	0.964	0.700	12.273	0.195	27	14	1	6	1.752	0.854
6.100	0.788	0.606	0.904	0.933	0.660	0.997	0.963	0.667	11.818	0.227	26	14	1	7	1.721	0.833
6.200	0.758	0.574	0.883	0.933	0.660	0.997	0.962	0.636	11.364	0.260	25	14	1	8	1.691	0.813
6.300	0.758	0.574	0.883	1.000	0.747	0.994	1.000	0.652	+Inf	0.242	25	15	0	8	1.758	0.833
7.700	0.727	0.542	0.861	1.000	0.747	0.994	1.000	0.625	+Inf	0.273	24	15	0	9	1.727	0.813
8.300	0.697	0.511	0.838	1.000	0.747	0.994	1.000	0.600	+Inf	0.303	23	15	0	10	1.697	0.792
9.300	0.667	0.481	0.814	1.000	0.747	0.994	1.000	0.577	+Inf	0.333	22	15	0	11	1.667	0.771
9.500	0.636	0.451	0.790	1.000	0.747	0.994	1.000	0.556	+Inf	0.364	21	15	0	12	1.636	0.750

**CSF IL-1 $\beta$**   
**Comparison of CSF IL-1 $\beta$  and IL-17A levels between CDRI vs non-infected group**

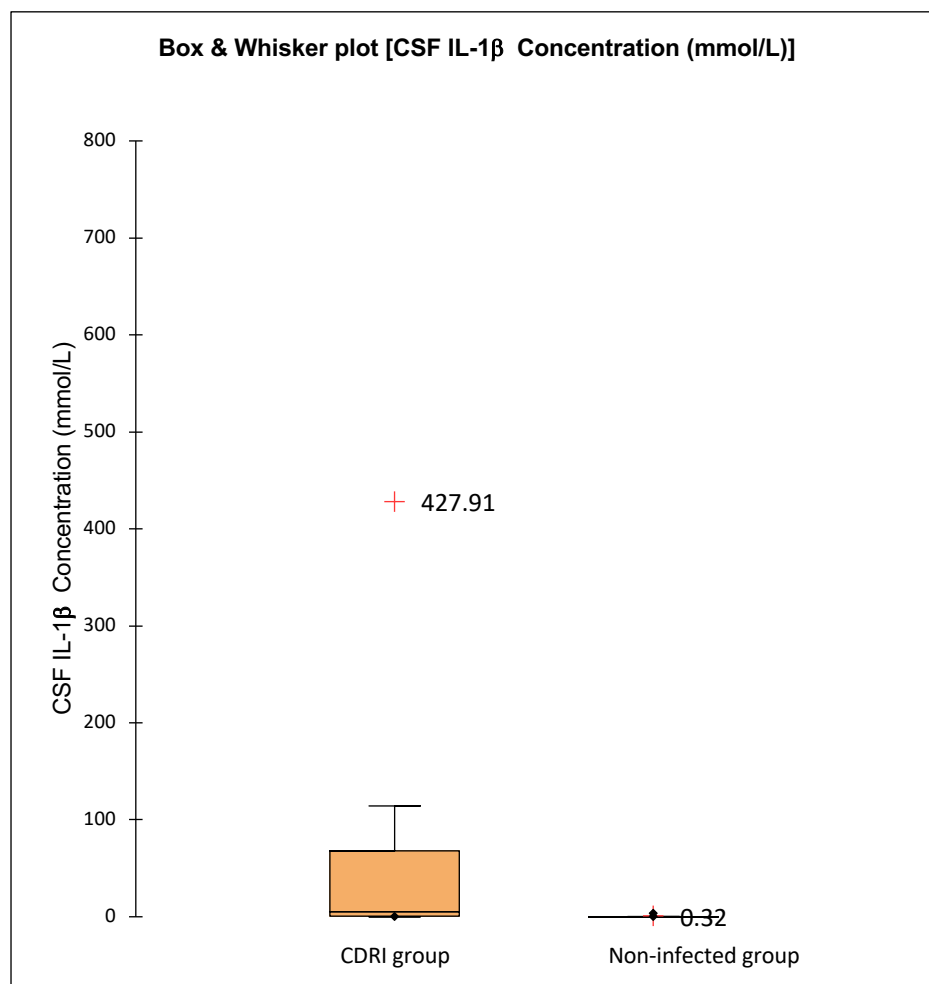

Statistic	CDRI group	Non-infected
Nbr. of observations	35	15
Minimum	0.010	0.002
Maximum	5000.000	3.030
1st Quartile	0.770	0.050
Median	5.215	0.080
3rd Quartile	67.973	0.150
Mean	427.908	0.319
Variance (n-1)	1283633.836	0.670
Standard deviation (n-1)	1132.976	0.818

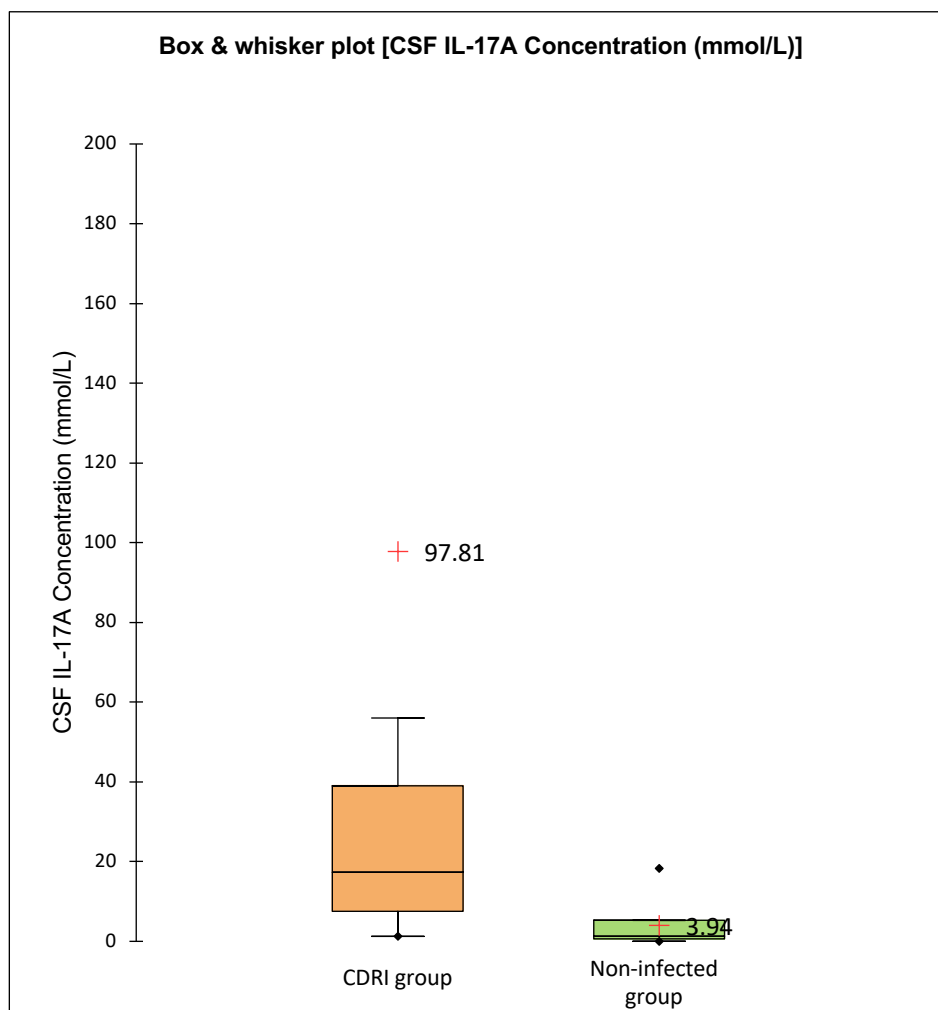

Statistic	CDRI group	Non-infected
Nbr. of observations	35	15
Minimum	1.250	0.020
Maximum	1891.010	18.290
1st Quartile	7.528	0.550
Median	17.255	1.210
3rd Quartile	39.088	5.230
Mean	97.813	3.936
Variance (n-1)	112791.974	35.238
Standard deviation (n-1)	335.845	5.936

Receiver-operating characteristic (ROC) curve analysis (CSF IL-1β) – CDRI vs Non-infected group

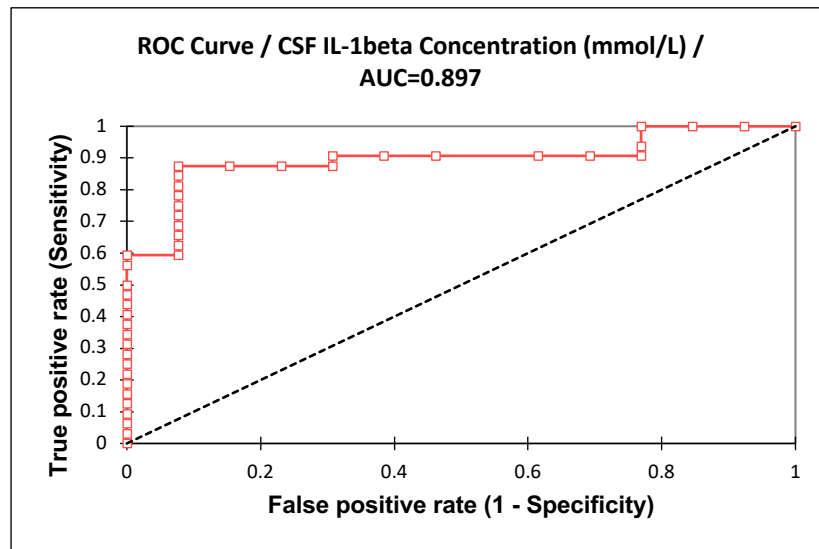

Area under the curve (AUC):			
AUC	Standard error	Lower bound (95%)	Upper bound (95%)
0.897	0.048	0.802	0.991

Difference	0.397
z (Observed value)	8.253
z (Critical value)	2.645
p-value (one-tailed)	< 0.0001
alpha	0.05

CSF IL-1beta Conc	Sensitivity	Lower bound (95%)	Upper bound (95%)	Specificity	Lower bound (95%)	Upper bound (95%)	PPV	NPV	LR+	LR-	TP	TN	FP	FN	Sensitivity+Specificity	Accuracy
0.002	1.000	0.867	0.997	0.077	0.004	0.379	0.727	1.000	1.083	0.000	32	1	12	0	1.077	0.733
0.003	1.000	0.867	0.997	0.154	0.027	0.463	0.744	1.000	1.182	0.000	32	2	11	0	1.154	0.756
0.007	1.000	0.867	0.997	0.231	0.062	0.540	0.762	1.000	1.300	0.000	32	3	10	0	1.231	0.778
0.010	0.938	0.778	0.989	0.231	0.062	0.540	0.750	0.600	1.219	0.271	30	3	10	2	1.168	0.733
0.040	0.906	0.738	0.975	0.231	0.062	0.540	0.744	0.500	1.178	0.406	29	3	10	3	1.137	0.711
0.050	0.906	0.738	0.975	0.308	0.104	0.611	0.763	0.571	1.309	0.305	29	4	9	3	1.214	0.733
0.070	0.906	0.738	0.975	0.385	0.151	0.677	0.784	0.625	1.473	0.244	29	5	8	3	1.291	0.756
0.080	0.906	0.738	0.975	0.538	0.261	0.796	0.829	0.700	1.964	0.174	29	7	6	3	1.445	0.800
0.090	0.906	0.738	0.975	0.615	0.323	0.849	0.853	0.727	2.356	0.152	29	8	5	3	1.522	0.822
0.100	0.906	0.738	0.975	0.692	0.389	0.896	0.879	0.750	2.945	0.135	29	9	4	3	1.599	0.844
0.130	0.875	0.701	0.959	0.692	0.389	0.896	0.875	0.692	2.844	0.181	28	9	4	4	1.567	0.822
0.150	0.875	0.701	0.959	0.769	0.460	0.938	0.903	0.714	3.792	0.163	28	10	3	4	1.644	0.844
0.220	0.875	0.701	0.959	0.846	0.537	0.973	0.933	0.733	5.688	0.148	28	11	2	4	1.721	0.867
<b>0.270</b>	<b>0.875</b>	<b>0.701</b>	<b>0.959</b>	<b>0.923</b>	<b>0.621</b>	<b>0.996</b>	<b>0.966</b>	<b>0.750</b>	<b>11.375</b>	<b>0.135</b>	<b>28</b>	<b>12</b>	<b>1</b>	<b>4</b>	<b>1.798</b>	<b>0.889</b>
0.280	0.844	0.665	0.941	0.923	0.621	0.996	0.964	0.706	10.969	0.169	27	12	1	5	1.767	0.867
0.350	0.813	0.630	0.921	0.923	0.621	0.996	0.963	0.667	10.563	0.203	26	12	1	6	1.736	0.844
0.390	0.781	0.596	0.901	0.923	0.621	0.996	0.962	0.632	10.156	0.237	25	12	1	7	1.704	0.822
0.410	0.750	0.562	0.879	0.923	0.621	0.996	0.960	0.600	9.750	0.271	24	12	1	8	1.673	0.800
0.890	0.719	0.530	0.856	0.923	0.621	0.996	0.958	0.571	9.344	0.305	23	12	1	9	1.642	0.778
0.940	0.688	0.499	0.833	0.923	0.621	0.996	0.957	0.545	8.938	0.339	22	12	1	10	1.611	0.756

Receiver-operating characteristic (ROC) curve analysis (CSF IL-17A) – CDRI vs Non-infected group

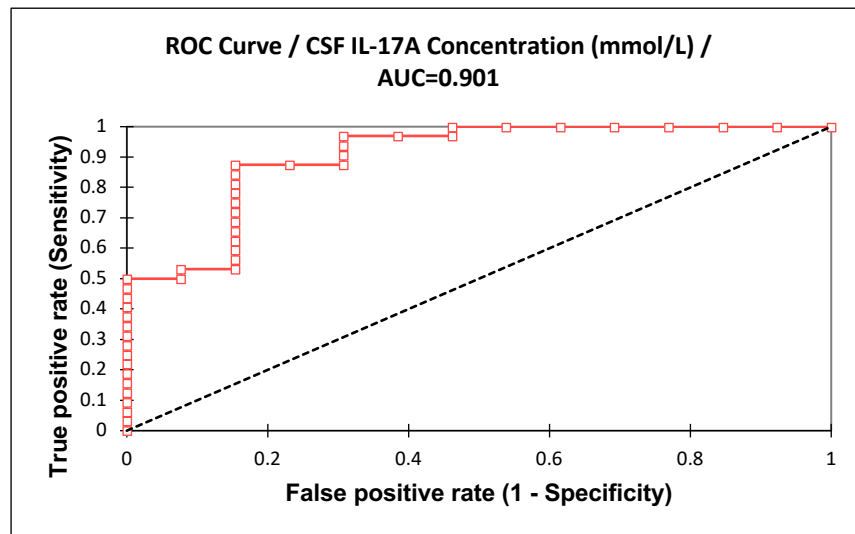

Area under the curve (AUC):				Difference	0.401
				z (Observed value)	7.658
				z (Critical value)	2.645
AUC	Standard error	Lower bound (95%)	Upper bound (95%)	p-value (one-tailed)	< 0.0001
0.901	0.052	0.799	1.000	alpha	0.05

CSF IL-17A Conc	Sensitivity	Lower bound (95%)	Upper bound (95%)	Specificity	Lower bound (95%)	Upper bound (95%)	PPV	NPV	LR+	LR-	TP	TN	FP	FN	itivity+Specif	Accuracy
0.020	1.000	0.867	0.997	0.077	0.004	0.379	0.727	1.000	1.083	0.000	32	1	12	0	1.077	0.733
0.040	1.000	0.867	0.997	0.154	0.027	0.463	0.744	1.000	1.182	0.000	32	2	11	0	1.154	0.756
0.120	1.000	0.867	0.997	0.231	0.062	0.540	0.762	1.000	1.300	0.000	32	3	10	0	1.231	0.778
0.550	1.000	0.867	0.997	0.308	0.104	0.611	0.780	1.000	1.444	0.000	32	4	9	0	1.308	0.800
0.740	1.000	0.867	0.997	0.385	0.151	0.677	0.800	1.000	1.625	0.000	32	5	8	0	1.385	0.822
1.150	1.000	0.867	0.997	0.462	0.204	0.739	0.821	1.000	1.857	0.000	32	6	7	0	1.462	0.844
1.210	1.000	0.867	0.997	0.538	0.261	0.796	0.842	1.000	2.167	0.000	32	7	6	0	1.538	0.867
1.250	0.969	0.820	0.998	0.538	0.261	0.796	0.838	0.875	2.099	0.058	31	7	6	1	1.507	0.844
1.390	0.969	0.820	0.998	0.615	0.323	0.849	0.861	0.889	2.519	0.051	31	8	5	1	1.584	0.867
2.200	0.969	0.820	0.998	0.692	0.389	0.896	0.886	0.900	3.148	0.045	31	9	4	1	1.661	0.889
3.550	0.938	0.778	0.989	0.692	0.389	0.896	0.882	0.818	3.047	0.090	30	9	4	2	1.630	0.867
3.630	0.906	0.738	0.975	0.692	0.389	0.896	0.879	0.750	2.945	0.135	29	9	4	3	1.599	0.844
4.260	0.875	0.701	0.959	0.692	0.389	0.896	0.875	0.692	2.844	0.181	28	9	4	4	1.567	0.822
5.230	0.875	0.701	0.959	0.769	0.460	0.938	0.903	0.714	3.792	0.163	28	10	3	4	1.644	0.844
<b>5.250</b>	<b>0.875</b>	<b>0.701</b>	<b>0.959</b>	<b>0.846</b>	<b>0.537</b>	<b>0.973</b>	<b>0.933</b>	<b>0.733</b>	<b>5.688</b>	<b>0.148</b>	<b>28</b>	<b>11</b>	<b>2</b>	<b>4</b>	<b>1.721</b>	<b>0.867</b>
6.230	0.844	0.665	0.941	0.846	0.537	0.973	0.931	0.688	5.484	0.185	27	11	2	5	1.690	0.844
6.310	0.813	0.630	0.921	0.846	0.537	0.973	0.929	0.647	5.281	0.222	26	11	2	6	1.659	0.822
6.560	0.781	0.596	0.901	0.846	0.537	0.973	0.926	0.611	5.078	0.259	25	11	2	7	1.627	0.800
7.310	0.750	0.562	0.879	0.846	0.537	0.973	0.923	0.579	4.875	0.295	24	11	2	8	1.596	0.778
7.600	0.719	0.530	0.856	0.846	0.537	0.973	0.920	0.550	4.672	0.332	23	11	2	9	1.565	0.756
9.120	0.688	0.499	0.833	0.846	0.537	0.973	0.917	0.524	4.469	0.369	22	11	2	10	1.534	0.733
9.530	0.656	0.468	0.808	0.846	0.537	0.973	0.913	0.500	4.266	0.406	21	11	2	11	1.502	0.711

**Serum Procalcitonin (PCT)**  
**Comparison of sPCT levels between CDRI vs non-infected group**

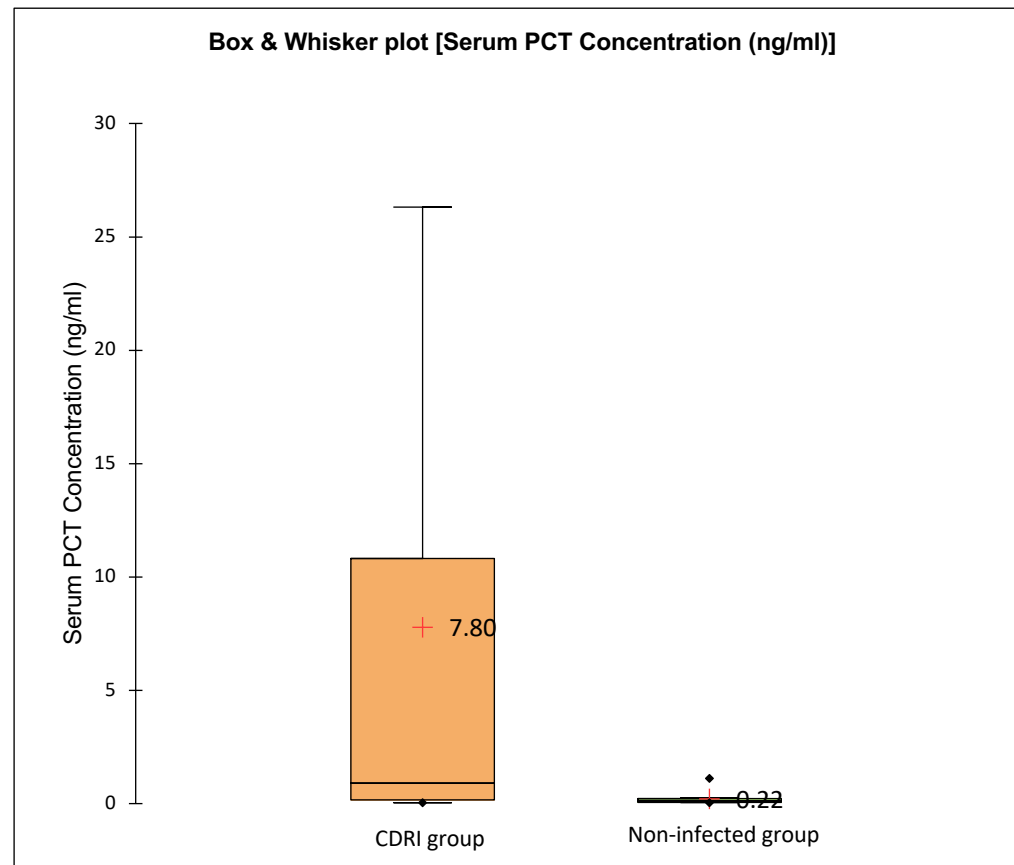

Statistic	CDRI group	Non-infected
Nbr. of observations	35	15
Minimum	0.040	0.050
Maximum	48.630	1.130
1st Quartile	0.160	0.055
Median	0.890	0.100
3rd Quartile	10.810	0.223
Mean	7.803	0.220
Variance (n-1)	151.259	0.109
Standard deviation (n-1)	12.299	0.329

Receiver-operating characteristic (ROC) curve analysis (Serum procalcitonin - sPCT)

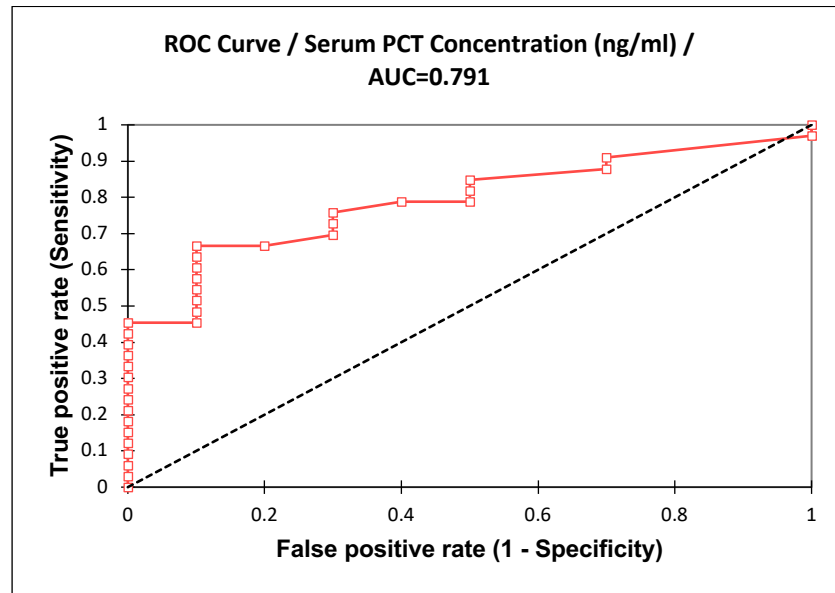

Area under the curve (AUC):				Difference	0.291
				z (Observed value)	4.165
				z (Critical value)	2.645
				p-value (one-tailed)	< 0.0001
AUC	Standard error	Lower bound (95%)	Upper bound (95%)	alpha	0.05
0.791	0.070	0.654	0.928		

sPCT Concentration (ng/ml)	Sensitivity	Lower bound (95%)	Upper bound (95%)	Specificity	Lower bound (95%)	Upper bound (95%)	PPV	NPV	LR+	LR-	TP	TN	FP	FN	Accuracy
0.040	0.970	0.825	0.998	0.000	0.009	0.345	0.762	0.000	0.970	+Inf	32	0	10	1	0.744
0.050	0.909	0.745	0.976	0.300	0.081	0.646	0.811	0.500	1.299	0.303	30	3	7	3	0.767
0.060	0.879	0.709	0.960	0.300	0.081	0.646	0.806	0.429	1.255	0.404	29	3	7	4	0.744
0.070	0.848	0.673	0.943	0.500	0.201	0.799	0.848	0.500	1.697	0.303	28	5	5	5	0.767
0.080	0.818	0.639	0.924	0.500	0.201	0.799	0.844	0.455	1.636	0.364	27	5	5	6	0.744
0.120	0.788	0.606	0.904	0.500	0.201	0.799	0.839	0.417	1.576	0.424	26	5	5	7	0.721
0.130	0.788	0.606	0.904	0.600	0.274	0.863	0.867	0.462	1.970	0.354	26	6	4	7	0.744
0.140	0.758	0.574	0.883	0.700	0.354	0.919	0.893	0.467	2.525	0.346	25	7	3	8	0.744
0.160	0.727	0.542	0.861	0.700	0.354	0.919	0.889	0.438	2.424	0.390	24	7	3	9	0.721
0.230	0.697	0.511	0.838	0.700	0.354	0.919	0.885	0.412	2.323	0.433	23	7	3	10	0.698
0.250	0.667	0.481	0.814	0.800	0.442	0.965	0.917	0.421	3.333	0.417	22	8	2	11	0.698
<b>0.260</b>	<b>0.667</b>	<b>0.481</b>	<b>0.814</b>	<b>0.900</b>	<b>0.541</b>	<b>0.995</b>	<b>0.957</b>	<b>0.450</b>	<b>6.667</b>	<b>0.370</b>	<b>22</b>	<b>9</b>	<b>1</b>	<b>11</b>	<b>0.721</b>
0.300	0.636	0.451	0.790	0.900	0.541	0.995	0.955	0.429	6.364	0.404	21	9	1	12	0.698
0.330	0.606	0.422	0.766	0.900	0.541	0.995	0.952	0.409	6.061	0.438	20	9	1	13	0.674
0.360	0.576	0.394	0.740	0.900	0.541	0.995	0.950	0.391	5.758	0.471	19	9	1	14	0.651
0.490	0.545	0.366	0.715	0.900	0.541	0.995	0.947	0.375	5.455	0.505	18	9	1	15	0.628

**Receiver-operating characteristic (ROC) curve analysis (CSF IL-1 $\beta$ ) – Gram positive vs Gram Negative CDRI**

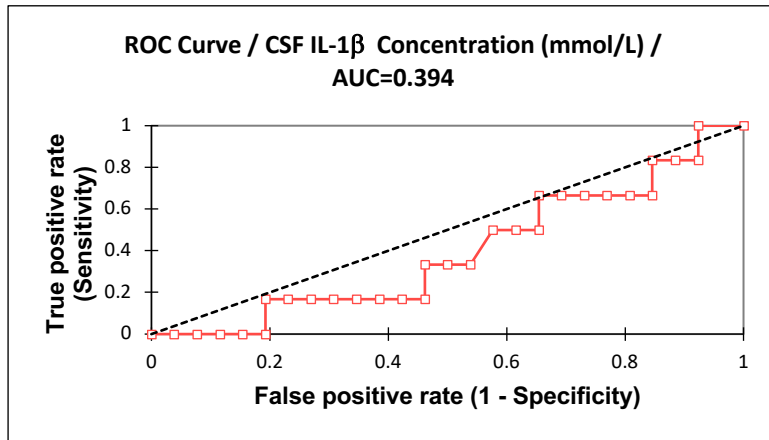

Area under the curve (AUC):			
AUC	Standard error	Lower bound (95%)	Upper bound (95%)
0.394	0.124	0.152	0.637

Difference	-0.106
z (Observed value)	-0.855
z (Critical value)	2.645
p-value (one-tailed)	0.804
alpha	0.05

**Receiver-operating characteristic (ROC) curve analysis (CSF IL-17A) – Gram positive vs Gram Negative CDRI**

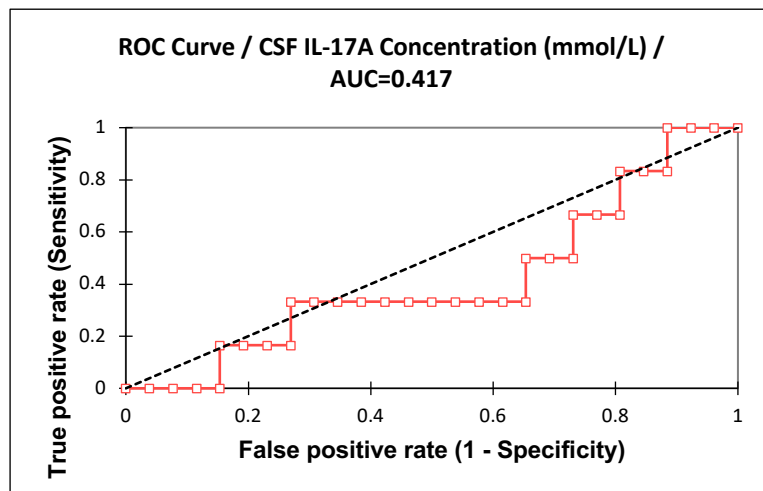

Area under the curve (AUC):			
AUC	Standard error	Lower bound (95%)	Upper bound (95%)
0.417	0.135	0.152	0.681

Difference	-0.083
z (Observed value)	-0.617
z (Critical value)	2.645
p-value (one-tailed)	0.731
alpha	0.05

### Development of an evidence-based care bundle

**Methodology:** Institute for Healthcare Improvement (IHI) comprehensive flowchart used for designing care bundle

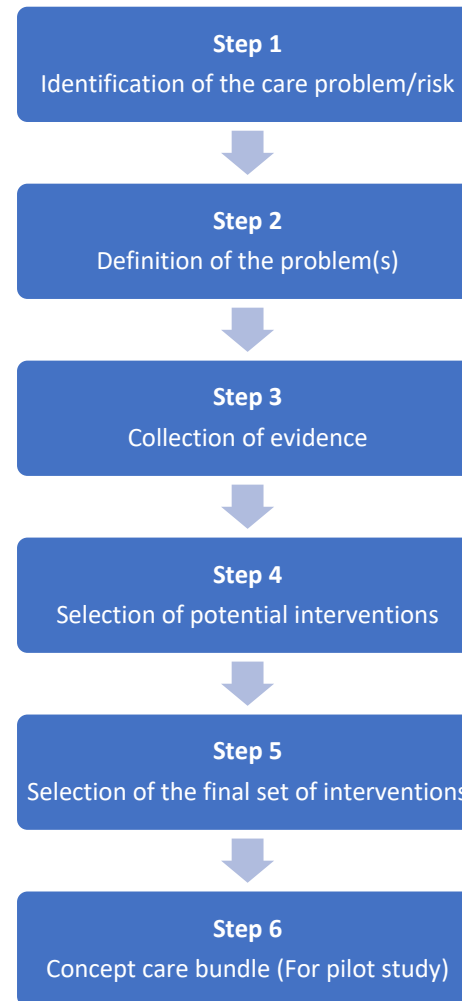

**IHI criteria:**

1. Care bundles have to consist three to a maximum of five evidence-based interventions (Care elements)
2. Elements to be applied together in every eligible patient
3. The multidisciplinary care team develops the bundle, with strong clinician agreement
4. Bundle elements should ideally be level 1 evidence
5. The bundle is used with a defined patient population in one location.
6. Bundle elements should be descriptive rather than prescriptive, to allow for local customization and appropriate clinical judgment.
7. Each bundle element is relatively independent.
8. The completion of an element could only be answered as “Yes” or “No”(Compliance measured using all-or-none approach)

**Assessment of quality of evidence:**

Indigenous modifiable risk factors and review of published literature along with consensus decisions with multidisciplinary team, used for choosing care elements. High and moderate level of evidences based on [Grading of Recommendations Assessment, Development and Evaluation] GRADE system in the published literature were used to design the care bundle.

Grade of recommendation	I Strong recommendation to do	IIa Moderate recommendation to do	IIb Weak recommendation to do	III Recommendation not to do
<b>Conclusions of evidence</b>	Benefits >>> risk & burdens	Benefits >> risk & burdens	Benefits >= risks & burdens	No benefit / Potentially harm
<b>A High level of evidence</b> Consistent evidence from well performed and high quality studies or systematic reviews (low risk of bias, direct, consistent, precise)	Strong recommendation based on high level of evidence	Moderate recommendation based on high level of evidence	Weak recommendation based on high level of evidence	Recommendation based on high level of evidence
<b>B Moderate /Low level of evidence</b> Evidence from studies or systematic reviews with few important limitations	Strong recommendation based on moderate/ low level of evidence	Moderate recommendation based on moderate/ low level of evidence	Weak recommendation based on moderate/ low level of evidence	Recommendation based on moderate/ low level of evidence
<b>C Very low level of evidence</b> Evidence from studies with serious flaws. Only expert opinion, or standards of care	Strong recommendation based on expert opinion	Moderate recommendation based on very low level of evidence Diverging expert opinions	Weak recommendation based on very low level of evidence Diverging expert opinions	Recommendation based on very low level of evidence Expert opinion

**Ref:** Grading quality of evidence and strength of recommendations. BMJ 2004;328(7454):1490.

## EXTERNAL VENTRICULAR DRAIN (EVD) CARE BUNDLE

S. No	INSERTION PHASE
1	<b>Site Preparation:</b> Complete or Wide clipping (NOT shaving) of scalp hair (to fit a medium-sized sterile, transparent semipermeable dressing) with cleansing of the site with aqueous antiseptic/soap solution
2	<b>Prophylactic antibiotic:</b> Single dose of prophylactic antibiotic (As per existent surgical antimicrobial policy) administered within 30-60 minutes prior to the incision
3	<b>Surgical hand preparation:</b> Hand jewelry, nail polish, wrist watches and artificial nails are removed. Surgical team decontaminates their hands initially using aqueous antiseptic surgical scrub (10% povidone-iodine) solution, and further with 0.5-2% chlorhexidine-alcohol handrub preparation prior to the procedure.
4	<b>Aseptic technique:</b> Procedure performed in a operating room with minimal personnel required and their restricted movement with strict aseptic precautions (full draping of patient exposing only surgical field with the surgeon donning gown, cap, mask and gloves)
5	<b>Skin preparation:</b> Surgical skin disinfection (Anterior approaches unless contraindicated) performed using 2-2.5% chlorhexidine gluconate-alcohol preparation and allowed to air-dry (approximately 3 minutes).
6	<b>Drain insertion:</b> Drain inserted in first attempt, preferably using anterior approaches with a tunneling distance of at least 5 cm, fixed with surgical staples in a curved (S) pattern and transparent dressing with borders secured using adhesive strips

S. No	MAINTENANCE PHASE
1	<b>Catheter indication assessment:</b> Daily assessment for the need of the drain is clearly documented with a clear indication
2	<b>Entry site dressing:</b> The status of the entry site transparent dressing is checked & documented DAILY; and changed, only if the dressing is soiled or loose.
3	<b>Positioning, levelling and securing:</b> Zero levelling (Tragus), prescribed chamber pressure gauge level and closed drainage is checked and documented on HOURLY basis and when patient is transported/moved.
4	<b>CSF sampling and manipulation:</b> Avoided unless indicated. If indicated, the indication is clearly documented and sampling port is handled using aseptic precautions.
5	<b>Drain Maintenance:</b> The 3-way taps are ensured to be open (unless patient is moved/transported) with chamber volume documented on HOURLY basis & drainage bag is changed when $\frac{3}{4}$ full using aseptic precautions (single-use sterile gloves). Hand hygiene performed before and after handling the bag.

**LUMBAR DRAIN (LD) CARE BUNDLE**

<b>S. No</b>	<b>INSERTION PHASE</b>
<b>1</b>	<b>Site Preparation:</b> Cleansing of the lumbar site (L3-L4 or L4-L5) with aqueous antiseptic/soap solution
<b>2</b>	<b>Prophylactic antibiotic:</b> Single dose of prophylactic antibiotic (As per existent surgical antimicrobial policy) administered within 30-60 minutes prior to the incision
<b>3</b>	<b>Surgical hand preparation:</b> Hand jewelry, nail polish, wrist watches and artificial nails are removed. Surgical team decontaminates their hands initially using aqueous antiseptic surgical scrub (10% povidone-iodine) solution, and further with 0.5-2% chlorhexidine-alcohol handrub preparation prior to the procedure.
<b>4</b>	<b>Aseptic technique:</b> Procedure performed in a operating room with minimal personnel required and their restricted movement with strict aseptic precautions (full draping of patient exposing only surgical field with the surgeon donning gown, cap, mask and gloves)
<b>5</b>	<b>Skin preparation:</b> Surgical skin disinfection performed using 2-2.5% chlorhexidine gluconate-alcohol preparation and allowed to air dry (approximately 3 minutes)
<b>6</b>	<b>Drain insertion:</b> Drain inserted in first attempt, with a tunneling distance of atleast 3-5 cm, fixed with transparent dressing with borders secured using adhesive strips

<b>S. No</b>	<b>MAINTENANCE PHASE</b>
<b>1</b>	<b>Catheter indication assessment:</b> Daily assessment for the need of the drain is clearly documented with a clear indication
<b>2</b>	<b>Entry site dressing:</b> The status of the entry site transparent dressing is checked & documented DAILY; and changed, only if the dressing is soiled or loose.
<b>3</b>	<b>Positioning, levelling and securing:</b> Zero levelling (Right atrium of heart in lateral position, Tragus if lying in supine position), prescribed chamber pressure gauge level and closed drainage is checked and documented on HOURLY basis and when patient is transported/moved.
<b>4</b>	<b>CSF sampling and manipulation:</b> Avoided unless indicated. If indicated, the indication is clearly documented and sampling port is handled using aseptic precautions.
<b>5</b>	<b>Drain Maintenance:</b> The 3-way taps are ensured to be open (unless patient is moved/transported) with chamber volume documented on HOURLY basis & drainage bag is changed when $\frac{3}{4}$ full using aseptic precautions (single-use sterile gloves). Hand hygiene performed before and after handling the bag.

**SUMMARY SHEET**

**Title:** A prospective cohort study on cerebrospinal fluid (CSF) diversion catheter-related infections in a tertiary referral neurosurgical care center.

**Introduction:**

Device-associated CNS infections is a major subgroup of health-care associated CNS infections occurring due to contamination or colonization of a temporary and permanently implanted neurosurgical device. The incidence of device-associated CNS infections varies between 1-45%, with the highest incidence observed in external ventricular drain-related infection (ERI). In a recent meta-analysis of 35 studies, the overall pooled incidence of EVD-related infection was 11.4 per 1000 catheter days and the rate of infection varies between 2-22% (Average – 8%). There were no Indian studies included in the meta-analysis report.

**Rationale:**

This study was conceptualised to detect the infection rates, risk factors associated and outcomes of life-threatening CSF diversion catheter-related infections, which are not reported from India.

**Objectives:**

- I. Determine the incidence of device-associated CNS infections following various CSF-diversion procedures.
- II. Identify the associated risk factors
- III. Analyze their outcomes
- IV. Evaluate novel CSF biomarkers and cytokines in its early diagnosis
- V. Identify risk-reduction strategies to develop evidence-based best practice care bundles.

**Methodology:**

Study design: Single-center, prospective, observational, cohort study.

Study period: 28.10.2020 – 27.10.2022 (2 years)

The principal and co-investigators recruited the study participants. Patients satisfying the inclusion-exclusion criteria were included in the study



Classification of patients using IDSA case definition as  
Contamination or Colonisation or Infection

(Based on clinical features, CSF biochemical and microbiological parameters)



CSF samples collected from patients with suspected CSF diversion catheter-related infections (CDRI) and stored at -20°C till further analysis



Patient data was collected from the electronic medical records (EMR) of SCTIMST  
Device days were also collected from the Hospital information system (HIS)



Estimation of biomarker levels: CSF & serum procalcitonin, CSF presepsin,  
CSF interleukins: IL-1beta & IL-17A and CSF lactate.



Data analysed for significance using XLSTAT- Life Sciences software version 2022.4.1  
& IHI comprehensive flowchart used for designing EVD & LD care bundle

**Results:**

During the 2-year period (October 2020-September 2022), a total of 578 CSF diversion catheters were inserted in 472 patients [240 (50.8%) were females and 232 (49.2%) were males]. Of the 417 drains inserted, 211 were external ventricular drains (EVD) and 206 were lumbar drains (LD). Of the 161 shunts inserted, 133 were ventriculo-peritoneal (VP) shunts, 19 were lumbo-peritoneal (LP) shunts, 6 were subduro-peritoneal (SDP) shunts, 2 were syringo-subarachnoid (SS) shunt and 1 cysto-peritoneal (CP) shunt. The mean age at the time of insertion was 34.4 years. Hydrocephalus was the commonest indication for a shunt insertion (71.4 %), while tumour excision surgery was the commonest indication for a drain insertion (58.2%). A total of 35 CSF diversion catheter-related infections (CDRI) were diagnosed (15 involving EVD, 11 involving LD, 8 involving VP shunts and 1 involving LP shunt). The average rate for EVD infection during this 2-year period was 11.12 per 1000 EVD days, while for LD infection was 11.86 per 1000 LD days. The infection rates for VP and LP shunts were 6 and 5.2 per procedure respectively. In this final analysis, Gram negative bacteria were the causative agents for CDRI in 28 cases (80%) while 6 cases due to Gram positive (17%) and 1 case was culture negative (3%). The most common organism causing CSF diversion catheter-related infection (CDRI) was *Klebsiella pneumoniae* (n=14, 40%), followed by *Acinetobacter baumannii* (n=7, 20%). Among the Gram positive bacteria, *Staphylococcus aureus* (n=3, 8.5%) was the commonest causative organism predominantly causing shunt-infections, while *Enterococcus faecalis* (n=2, 5.7%), predominantly causing drain infections. Presence of post-operative CSF leak, presence of associated scalp skin and soft tissue infection or systemic infection and presence of EVD/LD leak were statistically significant risk variables associated with CDRI (Fischer exact test). Duration of CSF drain had positive association (Coefficient: 0.063, 95% CI: 0.022-0.104, p=0.003) with development of drain infection while reduced CSF sampling was negatively associated (Coefficient: -1.776, 95% CI: -3.398 to -0.154, p=0.032) with development of new drain-associated infection. Posterior approaches within the occipital area chosen as point of insertion for shunts or drains was associated with increased risk of CDRI (Coefficient: 2.752, 95% CI: 0.470-5.033, p=0.018). Insertion of drain (EVD/lumbar) had 12 times higher risk of device associated CNS infection [HR:11.73, 95% CI: 3.53 - 38.96, p value =0.03] while posterior approach of EVD insertion (occipital) and presence of high pre-OP ASA score had 10 [HR:9.53, 95% CI: 1.54 - 59.05, p value = 0.01] and 8 times [HR:8.28, 95% CI: 1.56 - 43.83, p value = 0.013] higher risk of device-associated infection respectively. EVD and LD care bundles were designed using IHI comprehensive flowchart, based on indigenous-identified modifiable risk factors and published literature care elements. Estimation of area under the curve (AUC) using Receiver Operating Characteristic (Roc) curve analysis showed statistical significance (p<0.05) for the CSF biomarkers procalcitonin, presepsin, lactate, IL-1beta and IL-17A in diagnosing CDRI. The optimal cut-offs concentration estimated were 0.084 ng/ml, 922 pg/ml, 4.1 mmol/L, 0.270 pg/ml & 5.25 pg/ml respectively.

**Translational Potential:**

- I. Implementation of EVD/LD-associated CNS infection prevention care bundles (Pilot study at SCTIMST)
- II. Delineate best practice diagnostic algorithm in diagnosing CDRI
- III. The generated pilot data will be used for initiating future
  - A. Multicentric study to initiate randomised controlled trials (RCT) to evaluate the evidence-based care bundle, and CSF therapeutic drug monitoring (TDM)
  - B. Technology development programme
    - a) Cost-effective Rapid In-Vitro Diagnostics (IVD)
    - b) Coated catheters (with antimicrobial/antibiofilm compounds) in diagnosis and prevention of device-associated CNS infections respectively.



श्री चित्रा तिरुनाल आयुर्विज्ञान और प्रौद्योगिकी संस्थान, त्रिवेन्द्रम  
तिरुवनन्तपुरम - ६९५०११, केरल, इंडिया

SREE CHITRA TIRUNAL INSTITUTE FOR MEDICAL SCIENCES AND TECHNOLOGY, TRIVANDRUM  
Thiruvananthapuram - 695 011, Kerala, India  
(An Institute of National Importance under Govt. of India)

Grams : Chitramet, Phone : +91-471-2443152, Fax : +91-471-2550728 / 2446433, E-mail : sct@sctimst.ac.in, Website : www.sctimst.ac.in

SCTIMST/Projects/MB/P-5410/2022-23/1

Dated 21.11.2022

To,  
Indian Council of Medical Research (ICMR)

Respected Sir/Madam,  
SUB: Consent to retain the Equipment/Asset acquired in Project grant at SCTIMST – Reg.

The Project titled “A prospective cohort study on cerebrospinal fluid (CSF) diversion catheter-related infections in a tertiary referral neurosurgical care centre” (File: OMI/6/2020-ECD-I) [SCTIMST project code: P-5410] funded by Indian Council of Medical Research (ICMR) was completed on 27.10.2022 and the Project Completion Report, Statement of Expenditure and Utilization certificate have been submitted alongwith.

The following equipments/assets were purchased by the Institute out of the project grant based on the allocation in the above titled project.

1. Deep freezer vertical type freezer (-20°C): 1, Capacity: 262 litres, Brand: Cole Palmer, USA; Cost: 1,53,563 Indian rupees
2. Research Pipettes: 2, Capacity: 2-20 µl and 20-200 µl c, Brand: Eppendorf, Germany; Cost: 27300 Indian rupees

The above equipment/asset acquired out of Project grant are used for research purposes and for the benefit of the researchers of the Institute.

As part of compliance of Rule 233 of GFR, 2017, Indian Council of medical Research (ICMR) is requested to give kindly consent to retain the asset/equipment at SCTIMST. The consent may be communicated to SCTIMST at the earliest.

Thanking you.

Yours sincerely,

Dr. Dinoop K. P.

**Copy to:**

1. Finance and Accounts Division, SCTIMST

**Dr. DINOOP K. P.**  
Associate Professor - Clinical Microbiology  
Department of Microbiology  
Sree Chitra Tirunal Institute for  
Medical Sciences & Technology (SCTIMST)  
Thiruvananthapuram - 695011, Kerala, India  
KSMC Reg. No: 72406

**Project:** A prospective cohort study on cerebrospinal fluid (CSF) diversion catheter-related infections in a tertiary referral neurosurgical care center.

**ICMR File no:** OMI/6/2020-ECD-I

**SCTIMST Project code:** P-5410

**LIST OF EXPENDABLE ARTICLES PURCHASED**

S. No	Name of the expendable article	Numbers purchased	Numbers remaining
1.	Presepsin ELISA kits (Nordic Biosite, Sweden)	2 (96 well)	0
2.	Lactate estimation kits (Siemens Healthineers)	3 (Pack of 120)	1 pack
3.	IL-10/17A – qELISA kits	2 (96 well)	0
4.	IL-1 $\beta$ kits - qELISA kits	2 (96 well)	0
5.	Procalcitonin kits (BRAHMS KRYPTOR PCT Sensitive)	7 (Pack of 50)	Few tests (18)
6.	PCT controls and calibrators – Supplied Free of cost (Reagent-rental)	2 each (Free)	0
7.	BRAHMS KRYPTOR Buffer solution	2	0
8.	BRAHMS KRYPTOR Solution 1	2	0
9.	BRAHMS KRYPTOR Solution 2	2	0
10.	BRAHMS KRYPTOR Solution 3	2	0
11.	BRAHMS KRYPTOR Solution 4	2	0
12.	BRAHMS KRYPTOR Dilution cups	1 pack	Few tests (40)
13.	BRAHMS KRYPTOR Reaction trays	1 pack	Few tests (35)
14.	Preventive maintenance (PM) kit – 6 mon	1 (Free)	0
15.	Preventive maintenance (PM) kit – 1 year	1 (Free)	0

## LIST OF NON- EXPENDABLE ARTICLES PURCHASED



**1. Deep Freezer (-20°C), Cole Parmer**



**2. Pipettes: Eppendorf (2-20 µl & 20-200 µl)**

**BRAHMS KRYPTOR Compact Plus equipment was procured on Reagent-rental basis**

S. No	Name of equipment	Make/ Model	Cost FE/Rs	Date of Installation	Utilisation rate %	Remarks regarding maintenance/breakdown
1.	Deep freezer (-20°C) - 1	Cole Parmer, USA	Rs. 153563	15.03.2021	80% (storage capacity being utilised)	The equipment is provided with a warranty period of 3 years and is under annual maintenance contract (AMC)
2.	Research Pipette (Adjustable) – 2 [2-20 µl & 20-200 µl]	Eppendorf, Germany	Rs. 27,300	05.02.2021	100%, For all research sample handling	Functioning well and is calibrated at regular intervals.

Letter (SCTIMST/Projects/MB/P-5410/2022-23/1 dated 21.11.2022) drafted requesting ICMR to kindly grant consent for retention of the equipments/assets for ongoing and future research of the Department of Microbiology and Hospital infection Control Unit (HICU), SCTIMST.

**SREE CHITRA TIRUNAL INSTITUTE FOR MEDICAL SCIENCES AND TECHNOLOGY**

Thiruvananthapuram- 695011, India

(An Institute of National Importance under Govt. of India)

Phone (91) 471 2524445 Fax (91) 471 2550728

Email purchase@sctimst.ac.in

**PURCHASE ORDER**

P / H / / P2/ 2020-21/ N/ 5410 MBD/ /IMP-IND/ 2247

Date - 01/03/2021

To  
M/S

BIO-SYS  
TC 17/1286, VNRA-85,VIVEKANANDA NAGAR,  
EDAPPAZHANJI, TRIVANDRUM-695  
006.,Thiruvananthapuram,KERALA  
PIN: 695006  
Ph:0471-2352883, 6532883  
GSTIN : 32AOEPM7387N1ZC  
biosys.tvn@gmail.com

Dear Sirs,

Your offer no BS/BQ/20-21/962 dated 11/01/2021 , MAIL dated 10/02/2021 to supply the undermentioned stores is accepted subject to the terms & conditions of contract contained in this purchase order . Please note that the terms and conditions of this purchase order shall be the sole repository of this contract. Please acknowledge receipt & acceptance immediately.

Sl.No	Item	Cat.No.	Qty	Unit	Pack	Rate	Amount
1	EQDEPF0125 [COLE-PARMER ] HSN: 84184010 DEEP FREEZER VERTICAL TYPE. STABLE TEMP UPRIGHT LAB FREEZER, -20C, 9.3 CU FT; 230 VAC, 50 HZ, 262 LITER	16340-12	1	NO		153563.00	153563.00

TOTAL AMOUNT

153563

(Rs ONE LAKHS FIFTY-THREE THOUSAND FIVE HUNDRED SIXTY-THREE Only )

Delivery Date	-	Supply the item immediately on or before 31.03.2021
F.O.R	-	Our store 9 AM to 5 PM ( Ph: 0471-2524 527 / 157 )
GSTIN	-	32AAAJS0437M1Z4 , Reg.Date: 28/06/2017
Insurance	-	To be arranged by you at your cost
Despatch	-	Your arrangement
Payment Terms	-	'Electronic Transfer (NEFT) within 30 days of satisfactory installation and commissioning of the system' in case of equipment and 'Electronic Transfer (NEFT) within 30 days of receipt and acceptancs of items at Store, SCTIMST' in case of items other than equipment.
Remarks	-	<b>Three Copies of Bills to be submitted.</b> 1. Warranty: 3 years from the date of installation. 2. DSIR & Essentiality certificates enclosed. 3. AMC(Labour)-2.5% of the order cost with an annual escalation of 5% every year after warranty period. 4. CMC(Labour)-5% of the order cost with an annual escalation of 5% every year after warranty period. 5. The above rate is inclusive of GST@5%.



**PURCHASE ORDER**

P / H / / P2/ 2020-21/ N/ 5410 MBD/ /IMP-IND/ 2230

Date - 27/01/2021

To  
M/S

EPPENDORF INDIA LIMITED  
PLOT NO. 18, 19, 20 (PART)AMBIT PARK  
ROADSIDCO INDUSTRIAL ESTATE (SOUTH  
PHASE)AMBATTUR,CHENNAI,TAMIL NADU  
PIN: 600058  
Ph:044-66312233/ 66312222  
GSTIN : 33AABCE1667R1ZA  
bharathi.s@ependorf.co.in

Dear Sirs,

Your offer no PMC-81-EPC dated 05/01/2021 to supply the undermentioned stores is accepted subject to the terms & conditions of contract contained in this purchase order . Please note that the terms and conditions of this purchase order shall be the sole repository of this contract. Please acknowledge receipt & acceptance immediately.

Sl.No	Item	Cat.No.	Qty	Unit	Pack	Rate	Amount
1	EQIPT0112 [EPPENDORF ] PIPETTE EPPENDORF.(20ML - 200M) EPPENDORF RESEARCH PIPETTE (20ML - 200ML) Adjustable	3120000.054	1	NO		13000.00	13000.00
2	EQIPT0113 [EPPENDORF ] PIPETTE EPPENDORF.(2ML - 20ML). EPPENDORF RESEARCH PIPETTE (2ML - 20ML) Adjustable.	3120000.038	1	NO		13000.00	13000.00

TOTAL AMOUNT

26000

(Rs TWENTY-SIX THOUSAND Only )

Delivery Date	-	Supply the items on or before 22.02.2021.
F.O.R	-	Our store 9 AM to 5 PM ( Ph: 0471-2524 527 / 157 )
GSTIN	-	32AAAJS0437M1Z4 , Reg.Date: 28/06/2017
Insurance	-	To be arranged by you at your cost
Despatch	-	Your arrangement
Payment Terms	-	'Electronic Transfer (NEFT) within 30 days of satisfactory installation and commissioning of the system' in case of equipment and 'Electronic Transfer (NEFT) within 30 days of receipt and acceptances of items at Store, SCTIMST' in case of items other than equipment.
Remarks	-	<b>Three Copies of Bills to be submitted.</b> (1) Essentiality & DSIR certificates are forwarding along with this PO

If the items involve softwares, companies should avail software license in the name of "Director, SCTIMST" and the paper license/email license to be transferred to the concerned HOD and the same may be mentioned in the invoice.

Penalty clause for Delay Delivery: If the delivery is not effected on due date, the Director SCTIMST will have the right to impose penalty as 0.5% per week subject to a maximum of 10% of order value.

RECEIPT/ISSUE VOUCHER - Main Store - Departmental Items

Dept. PROJ/5410/CEREBROSPINAL FLUID  
Vendor: Biovision (GSTIN:32AIPPG7634R1ZL)

Bill No. 485  
Bill Date: 12/03/2021

P.O.N. P/H//P5/2020-21/N/5410 MBD/IND/813  
P.O. Date: 27/01/2021

R.V.No. 16950-1 I.V.No. 11873  
Date: 19/03/2021

Sl.	P.O. Code	Item Description	Brand	Unit	Ordered	Quantity			Free	Accepted	Amount (Rs)
						A. Received	Now Received	Rejected			
2	CHKITG0196	INVITROGEN PROQUANTUM HUMAN IL-1BETAKIT (CAT NO: A35574)	THERMO FISHER	NO	2.00	.00	2.00	.00	2.00	92585.43	

TOTAL AMOUNT 92585.43

Mode of Delivery: Door delivery  
Challan No.

Prepared by: Alka Ashok T. (2132/H)  
Executive Assistant - A

Above Material Inspected and Accepted as per Purchase Order conditions.

Dr. KAVITA RAJA, MD, MPhil  
Professor & Head  
Dept. of Microbiology  
SCTIMST  
Trivandrum - 695 011

Signature & Name: [Signature]  
Designation: SCTIMST  
Date: 13/4/21

Dr. DINOOP K. P.  
Assistant Professor - Clinical Microbiology  
Sree Chitra Thirunal Institute for  
Medical Sciences & Technology (SCTIMST)  
Trivandrum - 695011, Kerala

Received by: [Signature]  
Signature & Name: [Signature]  
Designation: [Signature]  
Date: 13/4/21

Materials accepted as shown above are in good condition,  
in correct quantity and payment may be made.

Dated: 19/03/2021

Purchase & Stores Officer

Date:

Accounts Officer

Date

RECEIPT/ISSUE VOUCHER - Main Store - Departmental Items

R.V.No. 16230.1    I.V.No. 11171    P.O.N. P/HI/P5/2021-22/NI/5410 MBD/IND/403    Dept. PROJ/5410/CEREBROSPINAL FLUID  
 Date: 08/09/2021    Date: 08/09/2021    P.O. Date: 05/08/2021    Vendor: Mount Biosciences (GSTIN:36AA XPA5436B1ZT)  
 P.O. Code    Item Description    Brand    Unit    Ordered    A. Received    Now Received    Rejected    Free    Accepted    Amount (Rs)

P.O. Code	Item Description	Brand	Unit	Ordered	A. Received	Now Received	Rejected	Free	Accepted	Amount (Rs)
1	CHKITG0197 NORDIC BIOSITE HUMAN PRESEPSIN ELISAKIT (CAT NO: EKX-5KS13J-96)	NORDIC BIOSITE	NO	1.00	.00	1.00	.00	.00	1.00	94447.50

TOTAL AMOUNT 94447.50

Mode of Delivery: Door delivery  
 Challan No. *Neena*  
 Prepared by: Neena K.H. (220071) 08/09/21  
 Executive Assistant - A

Above Material Inspected and Accepted as per Purchase Order conditions.  
**Dr. Dinakar K. P.**  
 Assistant Professor - Clinical Microbiology  
 Sree Chitra Tirunal Institute for  
 Medical Sciences & Technology (SCTIMST)  
 Trivandrum 682 019  
 Date: 08/09/2021

Received by *[Signature]*  
 Signature & Name: *S. Lakshmi S. L.*  
 Designation: *S. L.*  
 Date: 8/9/21

Materials accepted as shown above are in good condition, in correct quantity and payment may be made.

#P5410 *Lop Technician*

Dated: 08/09/2021

Accounts Officer

Date:

Purchase & Stores Officer

**SREE CHITRA TIRUNAL INSTITUTE FOR MEDICAL SCIENCES AND TECHNOLOGY**

Thiruvananthapuram- 695011, India

*(An Institute of National Importance under Govt. of India)*

Phone (91) 471 2524445 Fax (91) 471 2550728

Email purchase@sctimst.ac.in

**PURCHASE ORDER**

P / H / / P5/ 2021-22/ N/ 5410 MBD/ /IND/ 196

Date - 14/06/2021

To  
M/S

BIOCARE DIAGNOSTICS  
13/787-A1, KAMALA BUILDING  
ANNIE HALLROAD  
CHALAPPURAM P O, KOZHIKODE, KERALA  
PIN: 673002  
Ph: 9847009640  
GSTIN : 32AAOFB5438P1ZZ  
mail@biocarecalicut.com

Dear Sirs,

Your offer no NIL dated 27/04/2021 to supply the undermentioned stores is accepted subject to the terms & conditions of contract contained in this purchase order. Please note that the terms and conditions of this purchase order shall be the sole repository of this contract. Please acknowledge receipt & acceptance immediately.

Sl.No	Item	Cat.No.	Qty	Unit	Pack	Rate	Amount ₹
1	CHKITG0205 [BRAHMS ] HSN: 30049099 BRAHMS PCT SENSITIVE KRYPTOR (PRODUCT CODE: 825.050)		5	NO	50 TEST	30000.00	150000.00
2	CHREAG0479 [BRAHMS ] BRAHMS PCT KRYPTOR CALIBRATOR (PRODUCT CODE: 82591)		1	NO	6 VIALS(F OC)		
3	CHREAG0480 [BRAHMS ] BRAHMS PCT KRYPTOR CONTROL (PRODUCT CODE: 82592)		1	NO	FOC		
4	CHREAG0484 [BRAHMS ] HSN: 30049099 BRAHMS KRYPTOR BUFFER SOLUTION (PRODUCT CODE: 89970)		1	NO	1700 TESTS	20700.00	20700.00
5	CHREAG0485 [BRAHMS ] HSN: 30049099 BRAHMS KRYPTOR SOLUTION 1 (PRODUCT CODE: 89981)		1	NO	4 X 55 ML	4955.00	4955.00
6	CHREAG0486 [BRAHMS ] HSN: 30049099 BRAHMS KRYPTOR SOLUTION 2 (PRODUCT CODE: 89982)		1	NO	4 X 55 ML	8260.00	8260.00
					4 X 30	11868.00	11868.00



# SREE CHITRA TIRUNAL INSTITUTE FOR MEDICAL SCIENCES AND TECHNOLOGY

Thiruvananthapuram- 695011, India

(An Institute of National Importance under Govt. of India)

Phone (91) 471 2524445 Fax (91) 471 2550728

Email purchase@sctimst.ac.in

7	CHREAG0487	1 NO	ML		
	[BRAHMS ] HSN: 30049099				
	BRAHMS KRYPTOR SOLUTION 3 (PRODUCT CODE: 89983)				
8	CHREAG0488	1 NO	4 X 55 ML	8095.00	8095.00
	[BRAHMS ] HSN: 30049099				
	BRAHMS KRYPTOR SOLUTION 4 (PRODUCT CODE: 89984)				
9	CHREAG0489	1 NO	30 PLATES	15690.00	15690.00
	[BRAHMS ] HSN: 30049099				
	BRAHMS KRYPTOR DILUTION CUPS (24 WELLS) (PRODUCT CODE: 89985)				
10	CHREAG0490	1 NO	60 PLATES	39650.00	39650.00
	[BRAHMS ] HSN: 30049099				
	BRAHMS KRYPTOR REACTION TRAYS (96 WELLS) (PRODUCT CODE: 89986)				
11	CHKITG0198	1 NO	1 NO(FOC)		
	[BRAHMS ] HSN: 90279090				
	PM KIT (12 MONTH) KC PLUS (PRODUCT CODE: FS-0214-01)				
12	DSKITG0186	1 NO	1 NO(FOC)		
	[BRAHMS ] HSN: 90279090				
	PM KIT (6 MONTH) (PRODUCT CODE: C217011-FOR KC)				

TOTAL AMOUNT

259218

(Rs TWO LAKHS FIFTY-NINE THOUSAND TWO HUNDRED EIGHTEEN Only )

Delivery Date	-	<b>IMMEDIATELY ON OR BEFORE 14.07.2021</b>
F.O.R	-	Our store 9 AM to 5 PM ( Ph: 0471-2524 527 / 157 )
GSTIN	-	32AAAJS0437M1Z4 , Reg.Date: 28/06/2017
Insurance	-	To be arranged by you at your cost
Despatch	-	Your arrangement
Payment Terms	-	'Electronic Transfer (NEFT) within 30 days of satisfactory installation and commissioning of the system' in case of equipment and 'Electronic Transfer (NEFT) within 30 days of receipt and acceptancs of items at Store, SCTIMST' in case of items other than equipment.
Remarks	-	<b>Three Copies of Bills to be submitted.</b> 1.DSIR & Essentiality certificate are forwarding along with this PO. 2.Specify item code/catalogue no. in the invoice. 3.The above items are under reagent rental contract. 4. Item no. 2, 3, 11 and 12 should be supplied free of cost.

**SREE CHITRA TIRUNAL INSTITUTE FOR MEDICAL SCIENCES AND TECHNOLOGY**

Thiruvananthapuram- 695011, India

(An Institute of National Importance under Govt. of India)

Phone (91) 471 2524445 Fax (91) 471 2550728

Email purchase@sctimst.ac.in

**PURCHASE ORDER**

P / H / / P2/ 2022-23/ N/ 6119 MBD/ /IMP-IND/ 2181

Date - 25/08/2022

To  
M/SBIOCARE DIAGNOSTICS  
TC 16/31(1), GROUND FLOOR, SARASOMA  
COMPLEX, ULLOOR JN, MEDICAL COLLEGE  
P.O., THIRUVANANTHAPURAM, KERALA  
PIN: 695011

GSTIN : 32AAOFB5438P1ZZ

tvm@biocarecalicut.com

Dear Sirs,

Your offer no NIL dated 20/01/2021, EMAIL dated 20/02/2021 RATE CONTRACT-CC581868 to supply the undermentioned stores is accepted subject to the terms & conditions of contract contained in this purchase order. Please note that the terms and conditions of this purchase order shall be the sole repository of this contract. Please acknowledge receipt & acceptance immediately.

Sl.No	Item	Cat.No.	Qty	Unit	Pack	Rate	Amount ₹
1	CHKITG0205	825.05	2	NO	50 TESTS	31500.00	63000.00
	[BRAHMS ] HSN: 30049099						
	BRAHMS PCT SENSITIVE KRYPTOR (PRODUCT CODE: 825.050)						
2	CHREAG0479	82591	1	NO	6 VIALS		
	[BRAHMS ] HSN: 38220090						
	BRAHMS PCT KRYPTOR CALIBRATOR (PRODUCT CODE: 82591)						
3	CHREAG0480	82592	1	NO	2SETS OF 3 VIAL		
	[BRAHMS ] HSN: 38220090						
	BRAHMS PCT KRYPTOR CONTROL (PRODUCT CODE: 82592)						

TOTAL AMOUNT

63000

(Rs SIXTY-THREE THOUSAND Only)

Delivery Date	-	<b>Supply immediately.</b>
F.O.R	-	Our store 9 AM to 5 PM ( Ph: 0471 2524 527 / 157 )
GSTIN	-	32AAAJS0437M1Z4, Reg.Date: 28/06/2017
Insurance	-	To be arranged by you at your cost
Despatch	-	Your arrangement
Payment Terms	-	'Electronic Transfer (NEFT) within 30 days of satisfactory installation and commissioning of the system' in case of equipment and 'Electronic Transfer (NEFT) within 30 days of receipt and acceptancs of items at Store, SCTIMST' in case of items other than equipment.
Remarks	-	<b>Three Copies of Bills to be submitted.</b> 1) Under Reagent Rental Contract. 2) The above rate is inclusive of GST @5%. 3) Item No:2 & 3 should be provided free of cost.

**SREE CHITRA TIRUNAL INSTITUTE FOR MEDICAL SCIENCES AND TECHNOLOGY**

Thiruvananthapuram- 695011, India  
(An Institute of National Importance under Govt. of India)

Phone (91) 471 2524445 Fax (91) 471 2550728

Email purchase@sctimst.ac.in

**PURCHASE ORDER**

P / H / / P5/ 2022-23/ N/ 5410 MBD/ /IND/ 343

Date - 17/09/2022

To  
M/S

BIOVISION  
612 B, POICKATTUSSERY,  
CHENGAMANADU P.O  
NEDUMBASSERY,  
KOCHI  
9562900124,ERNAKULAM,KERALA  
PIN: 683578  
Ph:9562900124  
GSTIN : 32AIPPG7634R1ZL  
biokochi@yahoo.com

Dear Sirs,

Your offer no BKWIQ/22-23/284 dated 29/08/2022 to supply the undermentioned stores is accepted subject to the terms & conditions of contract contained in this purchase order. Please note that the terms and conditions of this purchase order shall be the sole repository of this contract. Please acknowledge receipt & acceptance immediately.

Sl.No	Item	Cat.No.	Qty	Unit	Pack	Rate	Amount ₹
1	CHKITG0195	A35611	1	NO	96 TESTS	47229.00	47229.00
	[ THERMO FISHER ]	HSN: 30021500					
	INVITROGEN PROQUANTUM HUMAN IL-17A KIT						
	(CAT NO: A35611)						

TOTAL AMOUNT

47229

(Rs FORTY-SEVEN THOUSAND TWO HUNDRED TWENTY-NINE Only )

Delivery Date	-	<b>IMMEDIATELY ON OR BEFORE 17.10.2022 (PLEASE SEE THE REMARKS)</b>
F.O.R	-	Our store 9 AM to 5 PM ( Ph: 0471 2524 527 / 157 )
GSTIN	-	32AAAJS0437M1Z4 , Reg.Date: 28/06/2017
Insurance	-	To be arranged by you at your cost
Despatch	-	Your arrangement
Payment Terms	-	'Electronic Transfer (NEFT) within 30 days of satisfactory installation and commissioning of the system' in case of equipment and 'Electronic Transfer (NEFT) within 30 days of receipt and acceptancs of items at Store, SCTIMST' in case of items other than equipment.
Remarks	-	<b>Three Copies of Bills to be submitted.</b> 1.Specify item code/catalogue no. in the invoice. 2.The item should be supplied as and when requested by user department (Ph. 0471 - 2524502)

If the items involve softwares, companies should avail software license in the name of "Director, SCTIMST" and the paper license/email license to be transferred to the concerned HOD and the same may be mentioned in the invoice.

Penalty clause for Delay Delivery: If the delivery is not effected on due date, the Director SCTIMST will have the right to impose penalty as 0.5% per week subject to a maximum of 10% of order value.



# SREE CHITRA TIRUNAL INSTITUTE FOR MEDICAL SCIENCES AND TECHNOLOGY

Thiruvananthapuram- 695011, India  
(An Institute of National Importance under Govt. of India)

Phone (91) 471 2524445 Fax (91) 471 2550728

Email purchase@sctimst.ac.in

## PURCHASE ORDER

P / H / / P5/ 2022-23/ N/ 5410 MBD/ /IND/ 368

Date - 29/09/2022

To  
M/S

REMEDEX PHARMA PVT LTD  
TC 1/830(1),OPP.HSS SCHOOL,KUMARAPURAM  
MEDICAL  
COLLEGE,,THIRUVANANTHAPURAM,KERALA  
PIN: 695011  
Ph:04714850707  
GSTIN : 32AAICR0878G1ZC  
remedextvm@gmail.com

Dear Sirs,

Your offer no NIL dated 05/09/2022 to supply the undermentioned stores is accepted subject to the terms & conditions of contract contained in this purchase order. Please note that the terms and conditions of this purchase order shall be the sole repository of this contract. Please acknowledge receipt & acceptance immediately.

Sl.No	Item	Cat.No.	Qty	Unit	Pack	Rate	Amount ₹
1	CHLAC09 [SIEMENS ] HSN: 38220090 LACTATE		2	NO	120T	9608.00	19216.00
2	CHCA001 [SIEMENS ] HSN: 38220090 CALIBRATOR CHEM I		1	NO		4115.00	4115.00

TOTAL AMOUNT

23331

(Rs TWENTY-THREE THOUSAND THREE HUNDRED THIRTY-ONE Only )

Delivery Date	-	IMMEDIATELY ON OR BEFORE 29.10.2022
F.O.R	-	Our store 9 AM to 5 PM ( Ph: 0471 2524 527 / 157 )
GSTIN	-	32AAAJS0437M1Z4 , Reg.Date: 28/06/2017
Insurance	-	To be arranged by you at your cost
Despatch	-	Your arrangement
Payment Terms	-	'Electronic Transfer (NEFT) within 30 days of satisfactory installation and commissioning of the system' in case of equipment and 'Electronic Transfer (NEFT) within 30 days of receipt and acceptances of items at Store, SCTIMST' in case of items other than equipment.
Remarks	-	Three Copies of Bills to be submitted. 1.Specify item code/catalogue no. in the invoice.

If the items involve softwares, companies should avail software license in the name of "Director, SCTIMST" and the paper license/email license to be transferred to the concerned HOD and the same may be mentioned in the invoice.

**Penalty clause for Delay Delivery:** If the delivery is not effected on due date, the Director SCTIMST will have the right to impose penalty as 0.5% per week subject to a maximum of 10% of order value.

The supply details should be intimated to the purchase division without fail by fax/courier.



**PURCHASE ORDER**

P / H / / P2/ 2022-23/ N/ 5410 MBD/ /IMP-IND/ 2188

Date - 17/10/2022

To  
M/S

BIOCARE DIAGNOSTICS  
TC 16/31(1), GROUND FLOOR, SARASOMA  
COMPLEX, ULLOOR JN, MEDICAL COLLEGE  
P.O., THIRUVANANTHAPURAM, KERALA  
PIN: 695011

GSTIN : 32AAOFB5438P1ZZ

tvm@biocarecalicut.com

Dear Sirs,

Your offer no NIL dated 20/01/2021, EMAIL dated 20/02/2021 RATE CONTRACT-CC581868 to supply the undermentioned stores is accepted subject to the terms & conditions of contract contained in this purchase order. Please note that the terms and conditions of this purchase order shall be the sole repository of this contract. Please acknowledge receipt & acceptance immediately.

Sl.No	Item	Cat.No.	Qty	Unit	Pack	Rate	Amount ₹
1	CHREAG0484	89970	1	NO	1700TES TS	21735.00	21735.00
	[BRAHMS ]						
	BRAHMS KRYPTOR BUFFER SOLUTION (PRODUCT CODE: 89970)						
2	CHREAG0485	89981	1	NO	4 X 55ML	5203.00	5203.00
	[BRAHMS ]						
	BRAHMS KRYPTOR SOLUTION 1 (PRODUCT CODE: 89981)						
3	CHREAG0486	89982	1	NO	4 X 55 ML	8673.00	8673.00
	[BRAHMS ]						
	BRAHMS KRYPTOR SOLUTION 2 (PRODUCT CODE: 89982)						
4	CHREAG0487	89983	1	NO	4 X 30ML	12461.00	12461.00
	[BRAHMS ]						
	BRAHMS KRYPTOR SOLUTION 3 (PRODUCT CODE: 89983)						
5	CHREAG0488	89984	1	NO	4 X55ML	8500.00	8500.00
	[BRAHMS ]						
	BRAHMS KRYPTOR SOLUTION 4 (PRODUCT CODE: 89984)						

TOTAL AMOUNT

56572

(Rs FIFTY-SIX THOUSAND FIVE HUNDRED SEVENTY-TWO Only )

Delivery Date - Supply as and when required by User Department (Ph:0471-2524502)  
F.O.R - Our store 9 AM to 5 PM ( Ph: 0471 2524 527 / 157 )  
GSTIN - 32AAAJS0437M1Z4 , Reg.Date: 28/06/2017  
Insurance - To be arranged by you at your cost  
Despatch - Your arrangement

**SREE CHITRA TIRUNAL INSTITUTE FOR MEDICAL SCIENCES AND TECHNOLOGY**

Thiruvananthapuram- 695011, India

(An Institute of National Importance under Govt. of India)

Phone (91) 471 2524445 Fax (91) 471 2550728

Email purchase@sctimst.ac.in

**PURCHASE ORDER**

P / H / P5/ 2022-23/ N/ 5410 MBD/ /TND/ 425

Date - 19/10/2022

To  
M/S

MOUNT BIOSCIENCES  
PLOT#14 II Floor CHANDRA PLAZA  
VIJAYAPURI COLONY NETAJI NAGAR ABOVE  
ANDHRA BANK KAPRAHYDERABAD,Ranga  
Reddy,TELANGANA  
PIN: 500062  
Ph:9849013581  
GSTIN : 36AAXPA5436B1ZT  
kmohan@mountbio.com

Dear Sirs,

Your offer no MB/SCTIMST/001/29082022 dated 01/09/2022 to supply the undermentioned stores is accepted subject to the terms & conditions of contract contained in this purchase order . Please note that the terms and conditions of this purchase order shall be the sole repository of this contract. Please acknowledge receipt & acceptance immediately.

Sl.No	Item	Cat.No.	Qty	Unit	Pack	Rate	Amount ₹
1	CHKITG0197	EKX-5KS13J-96	1	NO	96 PLATE	92100.00	92100.00
	[NORDIC BIOSITE ]	HSN: 38220090					
	NORDIC BIOSITE HUMAN PRESEPSIN ELISA KIT						
	(CAT NO: EKX-5KS13J-96)						

TOTAL AMOUNT

92100

(Rs NINETY-TWO THOUSAND ONE HUNDRED Only )

Delivery Date	-	<b>IMMEDIATELY ON OR BEFORE 19.11.2022</b>
F.O.R	-	Our store 9 AM to 5 PM ( Ph: 0471 2524 527 / 157 )
GSTIN	-	32AAAJS0437M1Z4 , Reg.Date: 28/06/2017
Insurance	-	To be arranged by you at your cost
Despatch	-	Your arrangement
Payment Terms	-	'Electronic Transfer (NEFT) within 30 days of satisfactory installation and commissioning of the system' in case of equipment and 'Electronic Transfer (NEFT) within 30 days of receipt and acceptancs of items at Store, SCTIMST' in case of items other than equipment.
Remarks	-	<b>Three Copies of Bills to be submitted.</b> 1.Specify item code/catalogue no. in the invoice.

If the items involve softwares, companies should avail software license in the name of "Director, SCTIMST" and the paper license/email license to be transferred to the concerned HOD and the same may be mentioned in the invoice.

**Penalty clause for Delay Delivery: If the delivery is not effected on due date, the Director SCTIMST will have the right to impose penalty as 0.5% per week subject to a maximum of 10% of order value.**

The supply details should be intimated to the purchase division without fail by fax/courier.

For each item :-

CGST (Extra)

9 %