

# SREE CHITRA TIRUNAL INSTITUTE FOR MEDICAL SCIENCES & TECHNOLOGY (SCTIMST)

(An Institute of National Importance - Govt. of India)  
Thiruvananthapuram, Kerala, India- 695011



## POST GRADUATE DIPLOMA IN NEURO TECHNOLOGY

### LOG BOOK

Submitted by,

**MOHAMMED FUAD M**  
**Emp.code:6776**

Department of Neurology  
SCTIMST, Trivandrum  
January 2015- December 2016

# CERTIFICATE



I Mr. Mohammed Fuad M hereby declare that I have performed all the procedures listed carried out the project, under report.

**Signature:** .....

**Name:** .....

**Place: Thiruvananthapuram**

**Date :**

Forwarded. He has carried out the minimum requirement of procedures.

**Signature :** .....

**Head of the department  
SCTIMST, Thiruvananthapuram**

# **CONTENTS**

**The Institute  
The Acknowledgement  
Course Details**

- 1. Electroencephalography**
- 2. EEG in Intensive Care Setup**
- 3. Prolonged Video EEG Monitoring**
- 4. Electrocorticography**
- 5. Polysomnography**
- 6. Nerve Conduction Study**
- 7. Electromyography**
- 8. Visual Evoked Potentials**
- 9. Brainstem Auditory Evoked Potentials**
- 10. Somatosensory Evoked Potentials**
- 11. Motor Evoked Potential**
- 12. Vagus Nerve Stimulation**
- 13. Optometry**
- 14. Botulinum Toxin Injection**
- 15. EEG-Fmri**
- 16. Technologist Role in Patient Safety**

**SREE CHITRA TIRUNAL INSTITUTE FOR MEDICAL SCIENCES  
& TECHNOLOGY (SCTIMST);  
THIRUVANANTHAPURAM, KERALA, INDIA.**



◀◀ **Hospital wing**



**BMT wing** ▶▶



◀◀ **Achutha Menon Centre**

The Sree Chitra Tirunal Institute for Medical Sciences and Technology (SCTIMST), Thiruvananthapuram is an Institute of National Importance established by an Act of the Indian Parliament. It is an autonomous Institute under the administrative control of the Department of Science and Technology, Government of India.

The Institute signifies the convergence of medical sciences and Technology and its mission is to enable the indigenous growth of biomedical technology, besides demonstrating high standards of patient care in medical specialties and evolving postgraduate training programs in advanced medical ties, biomedical engineering and technology, as well as in public health.

It has a 253-bedded hospital for tertiary care of cardiovascular and neurological diseases, a biomedical technology wing with facilities for developing medical devices from a conceptual stage to commercialization, center of excellence for training and research in public health.

The Institute has the status of a University and offers postdoctoral, and postgraduate courses in medical specialties, public health, nursing, basic sciences and health care technology. It is a member of the Association of Indian Universities and the Association of Indian Universities and the Association of Commonwealth Universities.

## **ACKNOWLEDGEMENT**

First and foremost I would like to thank the Head of the Department of Neurology Prof. Dr. Muraleedharan Nair and all other faculty members of the Department who guided me through the different phases of studies and encouraged and helped me in all the aspect of my training.

I thank Director of this institute Prof. Dr. Asha Kishore, Dean Dr. V. Kalliyana Krishnan, and Registrar Dr. A.V. George for this valuable advice, help and attention towards me.

I express my gratitude to Prof. Dr. Abraham.B. Kuruvila, Prof. Dr. C. Sarada, Prof. Dr. Sanjeev V. Thomas, Dr. Asha Latha, Dr.Syam, Dr. Ram Shekar N Menon, Dr.Ajith Cherian, Dr.Sapna Erat Sreedharan, Dr.Sruthi S Nair, Dr.Roopaa Rajan , Dr.Soumya Sundaram and Er.Koruth Varghese for their inevitable advice, which helped me for the successful completion of the course. I also thank all other faculty members of the Department who helped and encouraged me in technical studies.

I extended my heartfelt thanks to all Neuro-technologists, especially Mrs.Nandini (Sr. Scientific Assistant -Neurology) for their timely guidance and ideas that helped to learn more. I am also grateful to all the Neurology residents and PDFs of the Department of Neurology. And I am also very thankful to all my friends who helped me during my course in the Institute and the patients who were the core medium of the study.

At last I would like to acknowledge my sincere thanks to my seniors and juniors -and my colleagues for their co-operation in the work places and in the studies. I also thank my well-wishers who helped me in all the way during the last two years of my study.

## **PG Diploma in Neuro Technology**

PG Diploma in Neurotechnology (PGDNT) is a two-year academic course under the department of Neurology, Sree Chitra Tirunal Institute for Medical Sciences and Technology. During the course of study in the institute the student is imparted with both theoretical and practical knowledge with regard to the subject. The student in the Institute becomes exposed to very expensive machines of latest technology, which he/she may find difficult to find in ordinary places. Since the Institute is a tertiary care Hospital, the student gets the opportunity to study patients with varied neurological diseases.

The practical grounds where the student learn the work stands to be unmatched elsewhere in our country.

During the two - year period the student is given EEG, EMG and Video EEG posting to get trained in the specific diagnostics. In the EEG lab he gets to know about the connections; recording of EEG and activation procedures of international standards. The student also gets training in visual acuity testing and visual field charting since the Optometry Lab forms a part of the Department of Neurology. In the EMG posting the student learns the techniques for nerve conduction, eliciting evoked potentials and machine operation for assisting the consultants to perform the needle EMG and SFEMG study. The student is also trained in Video EEG lab for monitoring prolonged EEG studies like VEEG monitoring, SPECT studies, MSLT, Polysomnography etc. In the Institute the students are allowed for observing and doing Intra operative monitoring, neuro navigation and Electro corticography. The students also get opportunity to assist the programming of VNS therapy. With all this, the presence of many doctors with most excellence brings in the confidence for the student to work under strict conditions, where patient care is given the utmost importance.

# **ELECTROENCEPHALOGRAPHY EEG**

# **ELECTROENCEPHALOGRAPHY**

## **Introduction**

The electroencephalogram (EEG) is a recording of the electrical activity of the brain. Hans Berger made the first recording in 1929 although similar studies has been carried out in animals as early as 1870. The wave forms recorded are thought to reflect the activity of the surface of the brain, the cortex. The activity is influenced by the electrical activity form the brain structures underneath the cortex.

The electroencephalogram (EEG) is a unique and valuable measure of the brain's electrical function. It is a graphic display of a difference in voltages from two sites of brain function recorded over time.

For the successful interpretation of an abnormal EEG, one must first understand the criteria necessary to define normal patterns. While a normal EEG does not exclude a clinical diagnosis (i.e., epilepsy), an abnormal finding on EEG may be supportive of a diagnosis (i.e., in epilepsy), be indicative of cerebral dysfunction (i.e., focal or generalized slowing), or have nothing to do with the reason that the study was performed (i.e., in headache). It is the clinical application of the EEG findings that imparts the utility of EEG.

## **Basic physiology of cerebral potentials**

The origin of cerebral potentials is based upon the intrinsic electrophysiological properties of the nervous system. Identifying the generator source(s) and electrical field(s) of propagation are the basis for recognizing electrographic patterns that underlay the expression of the "brain waves" as normal or abnormal. Most routine EEGs recorded at the surface of the scalp represent pooled electrical activity generated by large numbers of neurons. Electrical signals are created when electrical charges move within the central nervous system. Neural function is normally maintained by ionic gradients established by neuronal membranes. Sufficient duration and length of small amounts (in microvolts (uV)) of electrical currents of cerebral activity are required to be amplified and displayed for interpretation. A resting (diffusion) membrane potential normally exists through the efflux of positive-charged (potassium) ions maintaining an electro-chemical equilibrium of  $-75$  mV. With depolarization, an influx of positive-charged (sodium) ions that exceeds the normal electrochemical resting state occurs. Channel opening within the lipid bilayer is through a voltage-dependent mechanism, and closure is time dependent. Conduction to adjacent portions of the nerve cell membranes results in an action potential when the depolarization threshold is exceeded. However, it is the synaptic potentials that are the most important source of the extracellular current flow that produces potentials in the EEG. Excitatory post-synaptic potentials (EPPs) flow inwardly (extracellular to intracellular) to other parts of the cell (sinks) via sodium or calcium ions. Inhibitory post-synaptic potentials (IPPs) flow outwardly (intracellular to extracellular) in the opposite direction (source), and involve chloride or potassium ions.

These summed potentials are longer in duration than action potentials and are responsible for most of the EEG waveforms. The brainstem and thalamus serve as subcortical generators to synchronize populations of neocortical neurons in both normal (i.e., sleep elements) and in abnormal situations (i.e., generalized spike-and-wave complexes).

**Volume conduction** characterizes the process of current flow from the brain generator and recording electrode. Layers of cortical neurons are the main source of the EEG. Pyramidal cells are the major contributor of the synaptic potentials that make up EEG (Figure 1.1A). These neurons are arranged in a perpendicular orientation to the cortical surface from layers III, IV, and VI. Volumes large enough to allow measurement at the surface of the scalp require areas that are  $>6 \text{ cm}^2$ , although probably  $>10 \text{ cm}^2$  are required for most IEDs to appear on the scalp EEG because of the attenuating properties incurred by the skull. All generators have both a positive and negative pole that function as a dipole (Figure 1.1B). The EEG displays the continuous and changing voltage fields varying with different locations on the scalp.

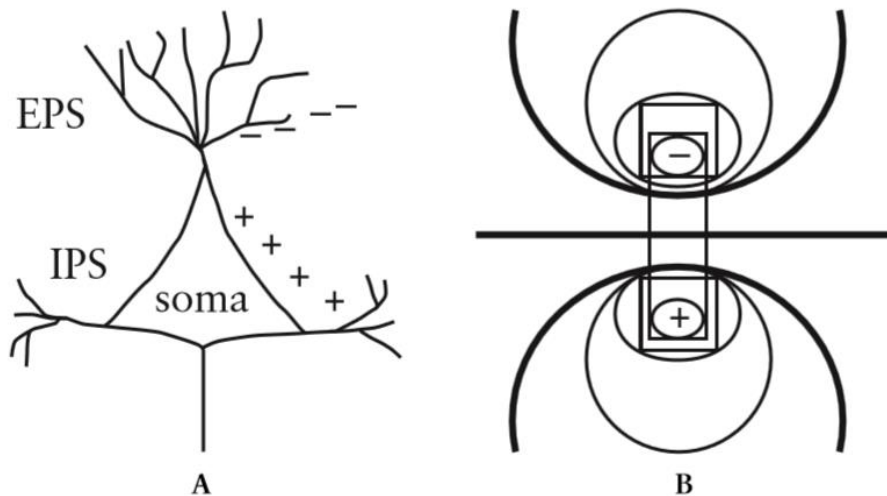
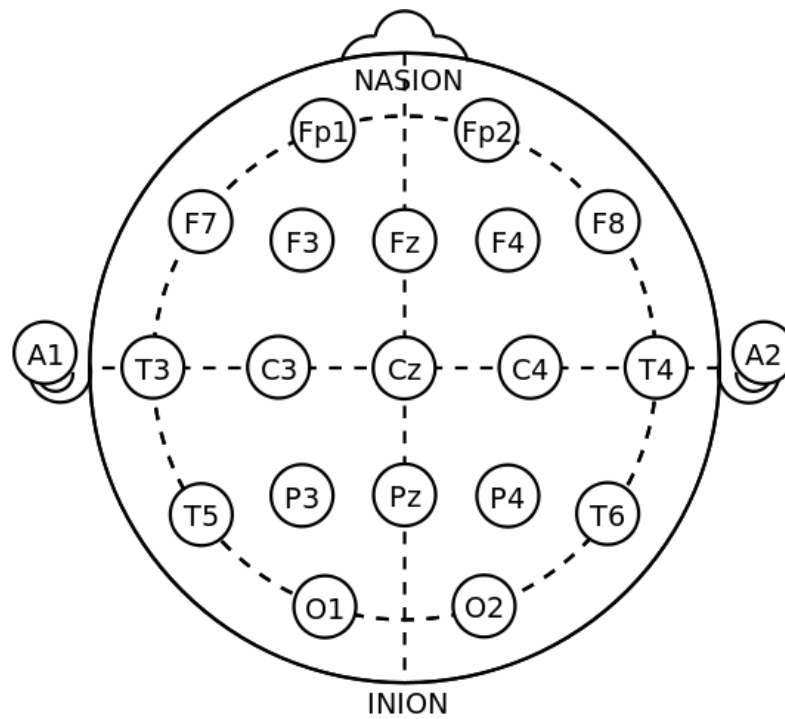

**FIGURE 1.1.** (A) A pyramidal cell with excitatory postsynaptic potentials and inhibitory postsynaptic potentials. (B) Dipole depicting a field of charge separation.

The nerve cells in the brain produce signals that are called action potentials. These action potentials move from one cell to another across a gap called the synapse. Special chemical called neurotransmitters, one will help the action potential to move to the next cell, the other will stop it moving to another nerve cell. The brain normally works hard to keep an equal amount of each of these neurotransmitters in the brain. EEG activity is quite small, measured in micro volts (uV) with the main frequencies of interest up to approximately 30 Hertz (Hz)

## Electrodes

Small metal discs called electrodes are placed on the scalp in special positions. The technologist who measures the head using the International 10-20 System identifies these positions. This relies on taking measurements between certain fixed points on the head. The electrodes are then placed at points that are 10% and 20 % of these distance. Each electrode site is labeled with a letter and a number. The letter refers to the area of the brain underlying the electrode. e.g. F - frontal lobe and T- temporal lobe. Even numbers denote the right side of the head and odd numbers are the left side of the head.



There are a great variety of electrodes that can be used. The majority are small discs of stainless steel, tin, gold or silver covered with a silver chloride coating. These normally have a lead attached. Alternative methods consist of a cap in which the electrodes are already embedded.

## Montages

EEG machines use a differential amplifier to produce each channel or trace of activity. Each amplifier has two inputs. An electrode is connected to each of the inputs.

### Differential amplifier

Differential amplifiers measure the voltage difference between the two signals at each of the inputs. The resulting signal is then amplified and then displayed as a channel of EEG activity.

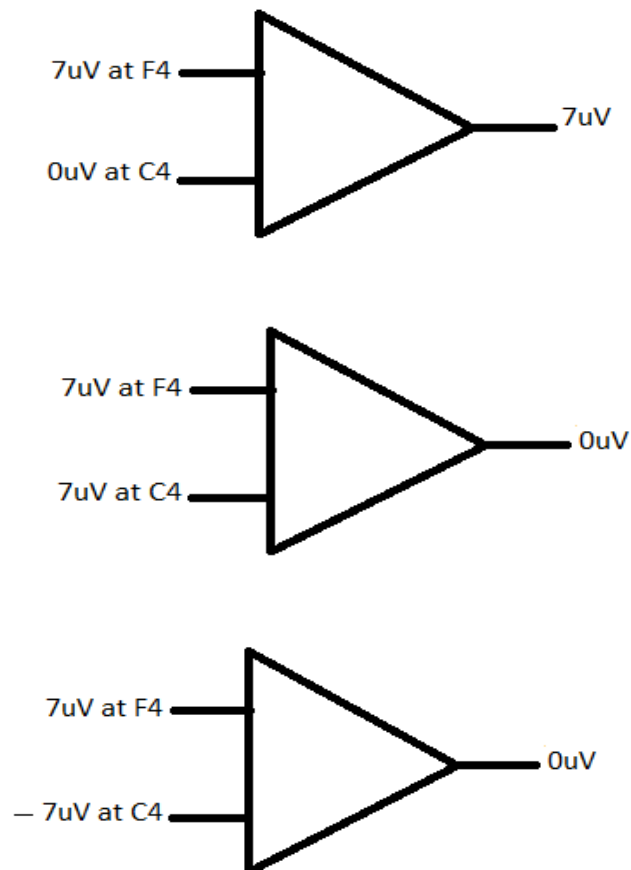

The manner in which the pair of electrodes are connected to each amplifier of the EEG machine is called a montage.

If one is mainly interested in a striking pattern, such as a spike-and-wave complex, then the display of such a pattern in a way that makes it stand out at a fairly large amplitude is desirable. For such a pattern, which is generally predominantly parasagittal, the use of the earlobe, whether ipsilateral or joined, is generally an excellent montage.

If, on the other hand, the abnormality looked for is a fairly low-voltage limited pattern, perhaps involving only the mid-temporal electrode and the reference electrode itself, there is great danger that the pattern can cancel out between the involved electrodes and not show up well. The use of reference electrodes also can lead to some rather complex situations in which there appears to be out-of-phase waveforms occurring both anteriorly and posteriorly (Garvin and Gibbs, 1971). In at least some instances, this phenomenon does not represent a physiological reversal of activity but the contaminated reference electrode effect on uninvolved electrodes (Reilly and Seward, 1980).

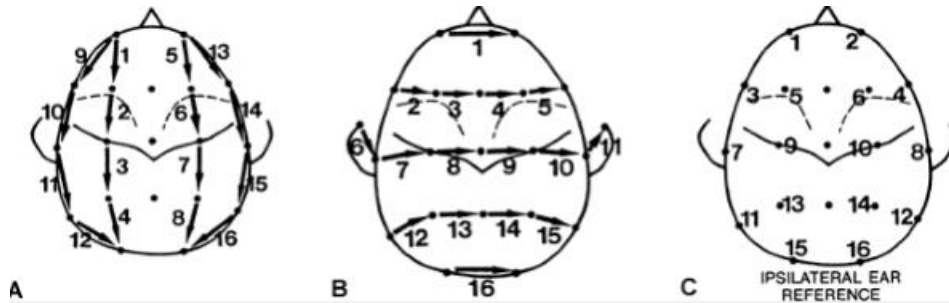

A: A representation of bipolar (scalp-to-scalp) montage in a longitudinal or anteroposterior (AP) direction. This montage is designed for easy comparison of left-right differences in the parasagittal or temporal area, but a montage with strict left-to-right sequence of sets of four could provide the same information. B: This is a typical bipolar (scalp-to-scalp) montage in the transverse or coronal direction. C: This is a reference (monopolar) montage. This particular sequence is designed to allow a front-to-back sequencing of channels to provide anatomic continuity

Common reference derivation: Each amplifier records the difference between a scalp electrode and a reference electrode. The same reference electrode is used for all channels. Electrodes frequently used as the reference electrode are A1, A2, the ear electrodes, or A1 and A2 linked together.

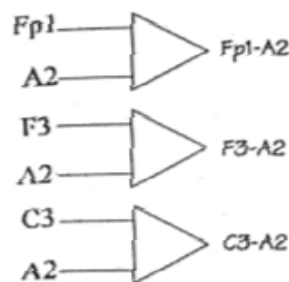

Average reference derivation: Activity from all the electrodes are measured summed together and averaged before being passed through a high value resistor. The resulting signal is then used as a reference electrode and connected to input 2 of each amplifier and is essentially inactive. All EEG systems will allow the user to choose which electrodes are to be included in this calculation.

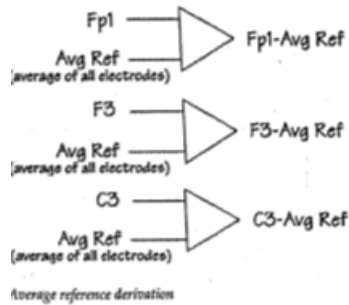

Bipolar derivation: These sequentially link electrodes together usually in straight lines from the front to the back of the head or transversely across the head. For example the first amplifier may have electrodes Fp1 and F3 connected to it and the second amplifier F3 and C3 connected to it

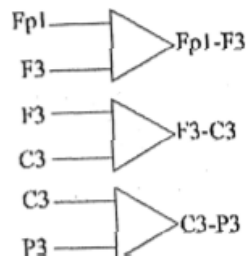

## Analogue EEG instruments

Conventional analogue instruments consist of an amplifier, a galvanometer and a writing device. A galvanometer is a coil of wire inside a magnetic field. The output signal from the amplifier passes through the wire causing the coil to oscillate. A pen mounted on the galvanometer moves up and down each time the coil moves. The pen draws the trace onto paper moving below it

High and low frequency filters and sensitivity control the amplifier output. The high and low frequency filter values will set the window within which the EEG activity is recorded. This is known as the bandwidth. The sensitivity controls the size of the activity displayed. For example a sensitivity of 10 micro (u)/mm means that a signal with amplitude of 100 micro(u)V will produce a 1 cm vertical deflection.

The speed at which the paper moves on will also affect the appearance of the waveforms.

## Digital EEG instruments

A digital EEG system converts the waveform into a series of numerical values. This process is known as Analogue-to-Digital conversion (ADC).

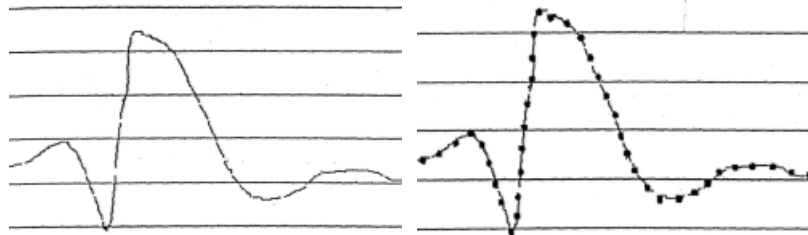

Analogue waveform

sampling rate of 240 Hz

The values can be stored in the computer memory, manipulated and then redisplayed as waveforms on a computer screen. The rate at which the waveform data is sampled in order to convert it into a numerical format is known as the sampling rate.

The sampling rate is usually expressed in Hz, for example 240 Hz is 240 times per second. The minimum acceptable sampling rate is 2.5 times greater than the highest frequency of interest but most digital EEG systems will sample at 240 Hz.

Some recordings which involve recording activity directly from the brain surface, may have activity of a higher frequency for example 200Hz. Therefore some digital EEG systems will have optional sampling rates of 480Hz available.

Sampling at rates lower than this will mean that when the signal is converted back to analogue form, it will not resemble the original waveform

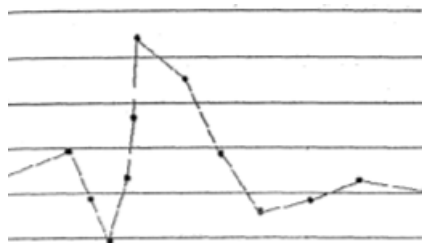

Sampling rate 50 Hz

A second factor that affects the accuracy of the waveform is *sampling skew*. Sampling skew occurs when all channels are not sampled simultaneously. Many digital EEG systems sample channel 1, then sample channel 2, then channel 3 etc. The time lag between sampling of each channel is known as sampling skew.

To reduce the sampling skew, some digital systems use *burst mode sampling*. This increases the speed between successive channels sampling in order to reduce the amount of sampling skew.

A third factor that affects the accuracy of digital EEG waveforms is the display. The accuracy of a monitor display depends on the number of points or pixels that are available. The number of pixels available is referred to as the screen resolution. Screen resolution is described in numbers that represent the pixels available in the horizontal and vertical axis.

A VGA display has a resolution of 640 x 480 pixels while a monitor with a Super VGA display will have a screen resolution of around 1024 x 768 pixels. A typical page of EEG contains 10 seconds of data. A digital EEG system, sampling at rates of 240 Hz will need to display 2400 samples horizontally for each recording channel. The highest screen resolutions available today do not have enough pixels to match the number of data samples. Systems that draw every other sample or every third sample in order to match the screen resolution will have the effect of reducing the sampling rate and displaying incomplete data. An accurate digital system will draw two data samples per screen pixel. This means that all data points can be displayed and sampling rates will not be decreased.

EEG signals that have been digitized can be manipulated to change the montage 'on-line' at the time of recording or 'off-line' after the recording is completed. This 'remontaging' is accomplished by recording all EEG channels with a common reference electrode. Regardless of the montage used to display the data while it is being recorded, data is stored into the computer memory in common reference mode. This allows the data to be displayed using different montages at a later time. Since digital systems store the analogue signal as numerical values, remontaging is a simple subtraction process, which results in cancellation of the common reference.

An example is shown in the next figure. The reference electrode A1 is common to both channels on input 2. It has the identical value in each channel. Remontaging these two channels together into one new channel is by subtraction, which mathematically will cancel the value at the reference electrode. The resulting channel will therefore display the potential difference between F3 (input 1) and F4 (input 2).

$$\begin{array}{rcc} \text{Input 1} & & \text{Input 2} \\ (F3 - A1) & - & (F4 - A1) \\ & \downarrow & \\ F3 - A1 & - & F4 + A1 \\ & \downarrow & \\ & F3 - F4 & \end{array}$$

## ARTIFACTS IN EEG

Although EEG is designed to record cerebral activity, it also records electrical activities arising from sites other than the brain. The recorded activity that is not of cerebral origin is termed artifact and can be divided into physiologic and extra physiologic artifacts. While physiological artifacts are generated from the patient, they arise from sources other than the brain (i.e., body). Extra physiologic artifacts arise from outside the body (i.e., equipment; environment)

Artifacts originate from a variety of sources, and their recognition, identification, and possible elimination are a primary responsibility of the electroencephalographic (EEG) technologist. If unrecognized, can lead to misinterpretation of the recordings.

Most recorded physiological activity will have a logical topographic field of distribution with an expected falloff of voltage potentials. Artifacts have an illogical distribution that defies the principles of localization

### Physiological artifacts

#### Eye Movements

The eye movements are generated by the corneo-retinal potential. This generator produces a direct current (DC) potential of approximately 50-100 mV. The electrodes involved are the ones closest to the eyeball: Fp1, Fp2, F7, and F8. This potential is best regarded as a dipole with the positive pole localized to the cornea and the negative pole to the retina. With an eye blink, the cornea rolls up due to normal Bell's phenomenon.

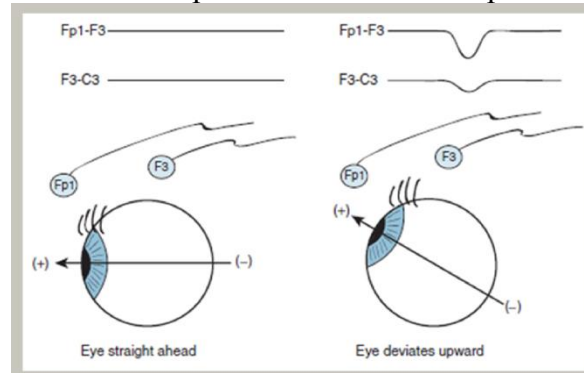

Upward movement is detected by a positive potential recorded at the supraorbital electrodes placed at Fp1 and Fp2. The activity recorded at F3 and F4 will be smaller in amplitude. When the eyeball moves in a downward direction, the inverse occurs. In EEG it appears as a bifrontal, diphasic, synchronous slow wave with field does not extend beyond frontal.

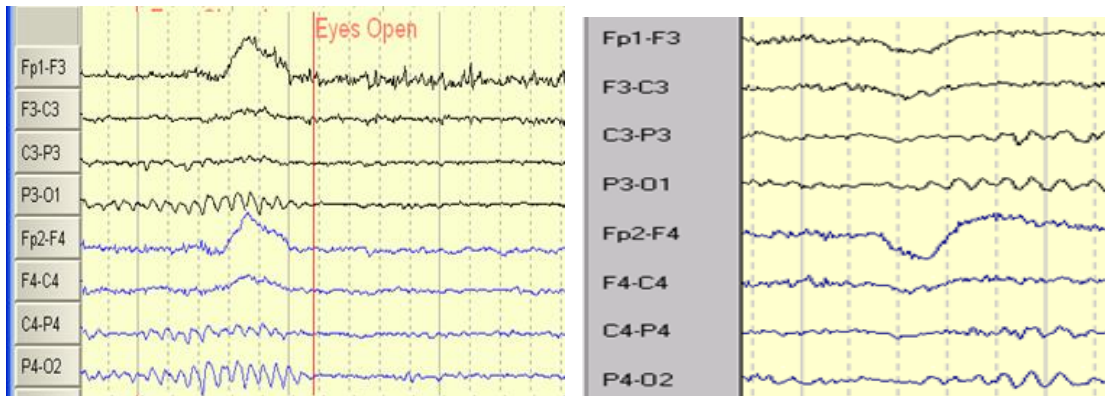

## Eyelid flutter

Less easy to evaluate. Rhythmic activity, at a frequency of 5-10 Hz, that will be intermittent but occurs for many seconds at a time. May mimic intermittent rhythmic theta/delta activity. It usually low voltage slowing. Detected at only the Fp1 and Fp2 electrodes. Lightly place the fingers over the eyelids, (for the identification) For the typical monitoring – place electrodes on the left/right side above outer canthi and left/right below outer canthi. Ocular artifact produces a phase reversal between infra orbital electrode and supra orbital electrode (ie, LOG and ROG)

## Nystagmus

Horizontal nystagmus normally occurs bilaterally, but it is often detected unilaterally. Electrode detected – either F7 or F8. Movement may be recorded only by the electrode on the side of the fast direction of the nystagmus. Mimic – seizures or other physiological patterns.

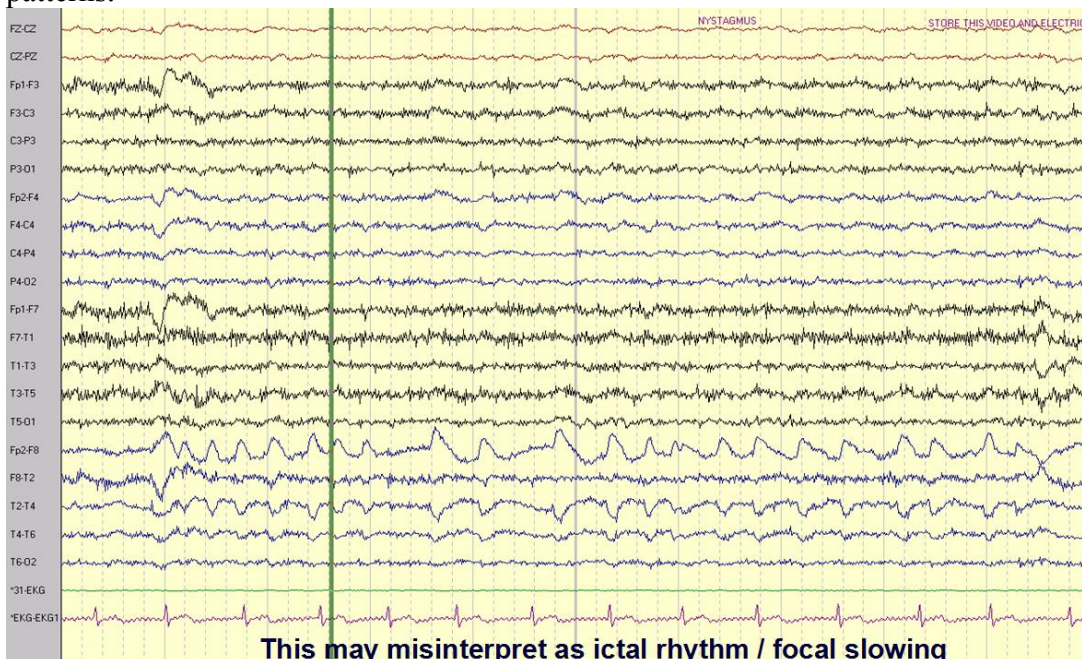

## Electroretinogram (ERG)

Low-voltage (<50microV) response to light stimulus of the retina. Appears in the anterior head regions. Especially during recording of electro-cerebral inactivity, retinal response can be seen during photic stimulation. Confused with an electrode artifact generated by a silver electrode reacting to the light source. Confused with abnormal frontal sharp waves. For the faster rates of flashes, cannot be respond. If the response is constant, with no delay to the stimuli, and no decrease in amplitude, then the artifact is most likely due to the chip in the plating of the electrode. This artifact can be identified by shielding the frontal electrodes with an opaque covering that prohibits the light source from being recorded by a faulty electrode.

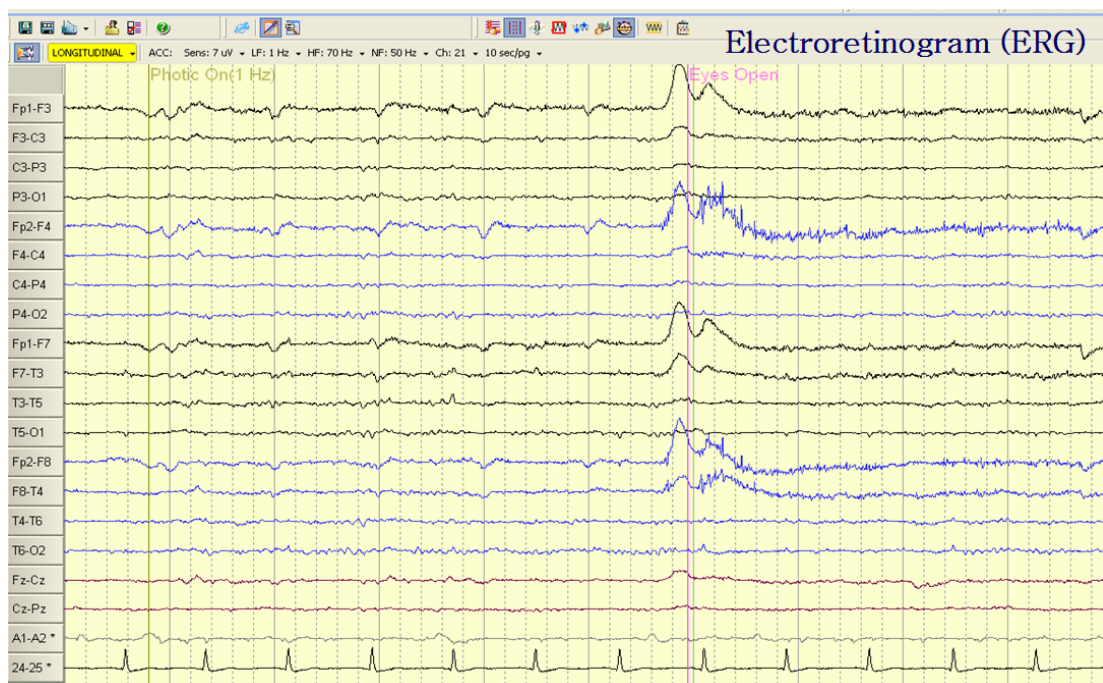

## Roving eye movement

It occurs during drowsiness with the frequency of less than 1 Hz. Direction of eyes is towards the side where the deflections are out of phase or where the pens separate (positivity). Slow roving movement artifact does not have abrupt changes.

## Lateral eye movement

Which has a more abrupt transition. With bipolar montages, positive and negative phase reversals are seen at the F7 and F8 electrodes.

## **Asymmetric eye movement artifact**

Whenever there is decreased movement of 1 eye, Asymmetrical placement of electrodes, Unilateral enucleation and prosthetic eye replacement, External ophthalmoplegia , Bell's palsy, Skull defect(eye movement artifact will be lower in amplitude ipsilateral to skull defect.) we can see asymmetric eye movement artifact.

## **Electrocardiographic Artifacts**

EKG artifact may appear simultaneously with prominent QRS complexes seen in several channels. Seen in obese patients, short necks and infants, in whom the head is close to the thorax. Most often detected by referential montages, especially those using ear electrodes as reference. Maximally over posterior head region. Extra systoles and cardiac arrhythmias are frequently detected in the temporal chain of bipolar montages but not in the parasagittal derivations, because the temporal electrodes are closer to the electrical field of the heart. These cardiac beats often mimic cerebral sharp waves, spikes, or even temporal theta activity and may be misinterpreted, because the field of electrical activity. The artifact is especially prominent in electro-cerebral inactivity (ECI) recordings.

## **Pulse artifact**

Usually confined to a single electrode. Appears as a slow-wave potential. It occurs when an electrode is placed over surface arteries. It is easily monitored by using an electrocardiogram (ECG) lead. The ECG signal will be time locked with lag (200-300msec) to the slow wave and always occurs at the same location in respect to the slow wave. Confirms the movement of the electrode with the pulse and alters its appearance on the EEG as pressure is applied. Slight change (1mm) in the position of electrode or head could rectify the artifact

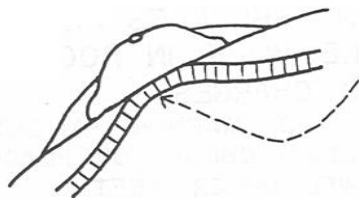

*By the movement of electrode with each pulsation cause more negativity to that particular electrode*

## **Ballistocardiograph**

Ballistocardiographic potentials are movement artifact that is time locked to the EKG. Microscopic movements of electrodes & wires from the recoil effect of beating heart produce rhythmic activity of low amplitude. Cardiac monitoring shows relationship of the cardiac signal to these pulsations, but not always time locked. Often mimic low-voltage theta, alpha, and beta frequencies, and mixtures of these low-voltage frequencies often resemble cerebral activity. Usually seen in brain death EEGs.

## **Pacemaker-generated artifact**

High-voltage. Short-duration spike activity easily monitored with electrodes placed on the chest. This artifact may be continuous or intermittent, depending on the type of pacemaker.

## **Cardiac arrhythmias**

Cardiac arrhythmias can be misinterpreted as ictal events because – it's evolving pattern. These patterns are easily monitored by recording from electrodes attached to the chest

## **Electromyographic Artifacts**

### **Lateral rectus artifacts**

Generated by low-voltage motor unit potentials localized to the lateral rectus muscles. They are typically recorded from the F7 and F8 surface electrodes, and the positive component is most commonly seen. Appears with a sharp positive deflection of very short duration with a slow falloff as the muscle relaxes. The activity is usually not seen from the corresponding contralateral electrode. (Ref: - Pedly). It mimics the appearance of a calibration signal.

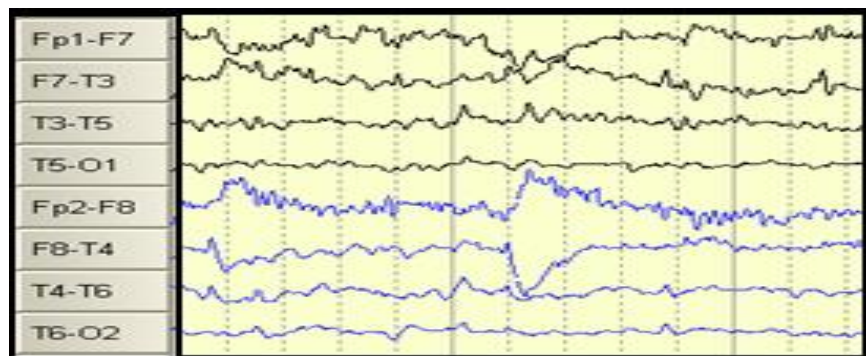

*A sharp transient is seen at the onset of each positivity in F8. Although this transient does resemble an epileptic spike, the fact that it occurs at the onset of each lateral eye movement helps to identify it as a lateral rectus spike artifact on gaze to right.*

### **Single motor units**

May be recorded from any electrode placed over one of the scalp muscles. They appear as repetitive negative or positive deflections that have a comb-like appearance and are typically recorded from a single electrode.

### **Frontalis electromyogram (EMG)**

Recorded over frontal electrodes when patients are tightly closing eyes the frontalis muscles are often activated by photic stimulation, and a photo-myoclonic response is recorded. It may obscure EEG activity and even be confused with a photo-convulsive response

### **Temporalis EMG**

Recorded from temporal electrodes when patients tightly close their jaws or make chewing movements. Frequent in patients with oral automatisms prior to or during an ictal event or who have orofacial dyskinesias

Note: EMG activity recorded over the frontal and occipital areas are common in tense individuals.

Most EMG artifacts can be reduced or eliminated with the use of relaxation techniques, such as reassuring the patient, comforting the patient, or simply massaging the muscle groups

The use of high-frequency filters to eliminate the artifact should be avoided, because these filters rarely eliminate the high frequency; rather, they alter its appearance from a sharp or spike wave to a more sinusoidal frequency that may look more like cerebral beta activity.



## **NON-PHYSIOLOGICAL ARTIFACTS**

Generated by recording electrode, equipment, environmental sources. Electrode artifacts related to poorly attached electrodes, high resistance, broken wire, changes in the lead-scalp interface, movement of electrode leads.

### **Instrumental and Environmental**

#### **Electronic noise:**

Generated by moving electrons within the recording amplifiers can be evident at high-gain settings.

#### **50-cycle interference recorded in an EEG:**

Due to high-impedance electrodes. It affect the input circuitry of the amplifier. Also affect the common mode rejection. Use of higher input impedances of the amplifiers can reduce 50 cycle artifact. Reduce the electrode impedance in to  $< 5\text{kohm}$  May not be from the EEG instrument (also can come from environment) electromagnetic fields produced by equipment like AC, fan, Fluorescent lights. Presence of 50-cycle artifact in all channels - may represent a problem with electrical safety.

#### **Capacitive, inductive, magnetic, and electrostatic artifacts:**

Usually related–movement of electrode wires, input cable, AC power cable. Cause of capacitive artifacts is the cable acts as a capacitor (insulator of cables act as dielectric of the capacitor)

#### **Electrostatic artifact:**

Static electricity stored on a variety of clothing and bedding manufactured of synthetic fibers. This voltage may be discharged by touching a metal bed rail, or even passed from person to person.

### **Drip artifact:**

Is due to drop of intravenous fluid falling near the electrode wires. It can reduce by use of micro drips instead of macro.

### **Ventilator Artifact:**

Single to multiple low – high voltage transients, Frequency of 2–40 Hz, Can mimic burst suppression pattern. Note each respiratory pump action on the EEG or observe the EEG by stopping the respirator for 20-30 sec.

### **Muscle artifacts vs 50 Hz artifact**

Not regular, not sinusoidal, Irregular in frequency and amplitude, Increase paper speed and count

### **Environment for artifact free recording:**

Quiet atmosphere, Comfortable bed, No synthetic carpeting, convenient control of lightening, proper shielding, Comfortable temperature and humidity levels to avoid sweating, tensions, restless. Keeping electrode leads close together, Move away from source (at least 10 feet) (since electrostatic induction is inversely proportional to the distance between the patient and source) Changing the orientation of the patient/source parallel to the electromagnetic lines of force. Locate the EEG lab at least 50 feet away from the AC feeders, transformers etc. One earth point for all equipment's. Shielding the source of artifact and machine with earthed metal shield

## **EEG Activity**

EEG activity can be broken down into 4 distinct frequency bands:

- Beta activity > 13 Hz
- Alpha activity 8 Hz-13 Hz
- Theta activity 4 Hz-7 Hz
- Delta activity < 4 Hz

### **Beta activity:**

Beta activity is a normal activity present when the eyes are open or closed. It tends to be seen in the channels recorded from the center or front of the head. Some drugs will increase the amount of beta activity in the EEG.

### **Alpha activity:**

Alpha is a normal activity when present in waking adults. It is mainly seen in the channels recorded from the back of the head. It is fairly symmetrical and has amplitude of 40 uV to 100 uV. It is only seen when the eyes are closed and should disappear or reduce in amplitude when the eyes are open.

### **Theta activity:**

Theta can be classed as both a normal and abnormal activity depending on the age and state of the patient. In adults it is normal if the patient is drowsy. However it can also indicate brain dysfunction if it is seen in a patient who is alert and awake. In younger patients, theta activity may be the main activity seen in channels recorded from the back and central areas of the head.

### **Delta activity:**

Delta is only normal in an adult patient if they are in a moderate to deep sleep. If it is seen at any other time it would indicate brain dysfunction. Abnormal activity may be seen in all or some channels depending on the underlying brain problem.

## **ATYPICAL BUT NORMAL WAVEFORMS DURING AWAKE**

### **Lambda:**

Lambda waves have a triangular shape. They occur posteriorly and symmetrically. Lambda occurs in the awake patient when the eyes stare at blank surfaces. They are normal waveforms and can occur singly or in long or short runs.

### **MU activity:**

The mu rhythm is a central rhythm of alpha activity frequency (usually 8~ 10 Hz) in which the individual waves have an arch-like shape. The voltage characteristics of the mu rhythm resemble those of alpha rhythm. The mu rhythm does not block with eye opening, but blocks unilaterally with movement of opposite extremity.

### **Posterior slow waves of youth:**

This activity was occurring most commonly in the EEGs of children 8 to 14 years of age. They are frequently bilaterally synchronous and symmetrical. Posterior slow waves of youth attenuate or block with eye opening and disappear during drowsiness along with alpha rhythms.

## **THE FEATURES OF EEG DURING DROWSINESS AND SLEEP**

The transition from awake to the drowsiness or stage I sleep, is marked by some profound changes in background activity of the EEG. The transition may be gradual or abrupt. The most prominent change is disappearance of the posterior dominant (alpha) rhythm. With the alpha rhythm gone, the background becomes dominated by theta activity, which occurs in generalized distribution, but is commonly most prominent in central or frontal region.

### **Vertex waves**

Also referred to as V waves or vertex sharp transients, this feature of EEG is most prominent on stage II sleep. The waves are aptly named, as their focus lies in Cz, the vertex. When the waves are larger amplitude, they are also picked up in the C3 and C4 electrodes. Their fields frequently spread to fronto-central regions and sometimes even extended to parietal regions. V waves usually are biphasic, but occasionally may be triphasic as well.

### **F waves or frontal waves**

Occasionally, a sharp transient like V waves appears on the frontal region without a corresponding wave present at the vertex. Such transient is referred to as F waves. V waves and F waves have the same significance. They are normal features of stage II sleep.

### **K complex**

The K complex is slow wave transient, seen in stage II sleep. The amplitude is generally maximum at the vertex. This is large amplitude wave. Sleep spindle immediately follow or associated the K complex. The K complex may last for nearly a second, but at times the duration can be large. The K complex can occur apparently spontaneously. They also can occur in response to sudden sensory stimulation such as unexpected loud noise in EEG laboratory.

### **Sleep spindles**

These are the burst of very rhythmic activity at 11 to 15 Hz that seen in stage II sleep and early phase of stage II sleep. Sleep spindles are generally occur in widespread distribution. Commonly they are of higher amplitude in the central areas, sometimes an anterior dominance is noted. Sleep spindles in adults should be bilaterally and essentially symmetrical

### **POSTS**

The positive occipital sharp transient of sleep (POSTS) are occur over the occipital regions on either side, being positive related to other areas, seen in stage II sleep. They occur singly or more commonly in runs. They are often bilaterally synchronous, but the same time they are asymmetrical on both sides.

### **The EEG in deeper stage of sleep**

The stage N sleep is characterized by a background that consists of irregular and semi-rhythmic theta activity mixed with mostly rhythmic delta activity in this stage delta activity comprises more than 20% of the record. Occasionally, few sleep spindles are mixed with this activity.

The stage IV sleep is the deeper stage of sleep. The EEG contains high amplitude, rhythmic theta and delta activity. The delta activity which comprise more than 50% of the record.

### **REM sleep**

The EEG during rapid eye movement (REM) sleep is different from the other stages of sleep. The background is paradoxically similar to that seen in wakefulness with eyes open.

### **Paroxysmal epileptiform abnormalities**

The term paroxysmal activity refers to activity that shows changes in amplitude or frequency which occur with sudden onset and offset and that stands out distinctly from the background activity. Paroxysmal abnormalities can be classified in to epileptiform abnormalities and periodic patterns.

### **Epileptiform Discharges**

#### **Spike discharges**

A spike discharge is defined as a transient that is clearly distinguished from the background activity, has a pointed peak at a paper speed 30mm/sec./ and has a duration of 20 to 70 ms. It is usually surface negative and is of variable amplitude.

#### **Sharp wave discharges**

A spike discharge is defined as a transient that is clearly distinguished from the background activity, has a pointed peak at a paper speed 30mm/sec., and has a duration of 70 to 200 ms. Amplitude is variable, and like spikes, sharp waves usually surface negative.

#### **Polyspikes or multispikes**

Spike discharges are usually monophasic or biphasic. The term polyspike is used when several spikes comprise a single waveform. As with spike discharges, polyspikes discharges may also be accompanied by slow waves.

#### **Spike and wave complexes**

Spike and wave complex refers to the activity, which shows a spike or sharp wave is accompanied by a slow wave, usually of same polarity.

### **Focal epileptiform abnormalities**

Inter-ictal epileptiform abnormalities manifest themselves as focal spikes or sharp waves, or focal spike and wave discharges. Their presence helps to confirm the clinical suspicion of a focal or partial seizure.

## **Generalized epileptiform discharges**

### **3 Hz spike and wave discharges**

This pattern is classically seen in absence seizures. It consists of bilaterally symmetrical and synchronous complexes, each made up of a high amplitude spike and wave, surface negative spike and wave. The complexes repeat at a rate of 3 Hz and appear in a generalized distribution, maximum amplitude on frontal and rarely in the occipital areas. At the onset of discharges, repetition rate may be faster (4Hz), whereas towards the end it becomes slower (2.5 Hz). They are precipitated in hyperventilation.

### **Generalized atypical fast spike and wave discharges**

This pattern lacks the typical appearance and repetition rate of 3 Hz spike. It consists of 3 to 5 Hz spike and wave discharges that show variations both in rate and morphology. The waveform may be mixture of spike and wave complexes and polyspike and wave complexes.

### **Generalized slow spike and wave discharges**

This pattern consists of sharp and slow wave complexes occurring at a rate of less than 2.5 Hz. It also has been called "petit mal variant". The discharges are bilaterally synchronous and generalized, although fluctuating asymmetry is not uncommon. It may last for several seconds. This pattern is the features of the diagnosis of Lennox-Gastaut syndrome.

### **Generalized polyspike and wave discharges**

Generalized polyspike or polyspike and wave complexes may occur as an Interictal phenomenon in patient with primary generalized epilepsy (often myoclonus) and in Lennox-Gastaut syndrome. Sometimes the discharges may accompanied by myoclonic jerks.

### **Hypsarrhythmia**

This pattern consists of continuous, high amplitude 1 to 3 Hz irregular, disorganized background activity and shifting spike foci. It occurs in most patients with infantile spasms. During sleep, the activity may become discontinuous.

### **Abnormal periodic paroxysmal patterns**

These are defined as stereotyped recurrences of paroxysmal complexes at relatively fixed intervals. They should be present throughout the entire tracing or a major portion of it. The discharges should stand out from the background.

## **Generalized periodic paroxysmal patterns**

### **SSPE**

The EEG in SSPE may be sufficiently specific to suggest the diagnosis. The periodic discharges consist of high amplitude (100 to 1000 uV) complexes - each consists of one or two slow waves - that recur at intervals of several seconds. The interval between the complexes may have a range of 4 to 14 seconds. Each complex may last from 0.5 to 3 seconds. The activity is often fronto-central dominant and may accompany the myoclonic jerks.

### **Creutzfeldt Jakob Disease**

The periodic complexes consist of sharp waves of 100 to 300 ms duration that occur at much faster rate than those in SSPE. The interval remains constant in a given patient. Sometimes the complex have a triphasic configuration.

### **Herpes Simplex Encephalitis**

The periodic discharges may be focal or liberalized to start with, but later they become generalized. The usual site is temporal or temporo-frontal. The discharge consists of large sharp waves 100 to 500uV in amplitude, having a duration of up to 1 second and occurring at a interval of 2 to 4 seconds.

### **Suppression Burst Pattern**

This may be considered as a periodic pattern, since it consists of periodic bursts of activity with intervals between in which the background activity is markedly attenuated to less than 10 uV. The pattern is indicative of severe encephalopathy and may result from cerebral anoxia, head trauma and severe drug intoxication as well as deep anesthesia.

### **Triphasic waves**

Triphasic wave may sometimes occur in periodic fashion. Each waveform shows a prominent positive phase preceded and followed by negative phases. Classic triphasic waves show a time delay between their appearance in the frontal and occipital area. The wave are usually frontally dominant, bilaterally synchronous and generalized.

## Periodic discharges

Stereotyped activities in the form of complexes repeating in constant time intervals and persisting for a substantial period of the record

They are commonly classified as:

- ✓ Periodic lateralized epileptiform discharges (PLEDs)
- ✓ Bilateral independent PLEDs(BIPLLEDs)
- ✓ Generalized periodic epileptiform discharges (GPEDs)
- ✓ Triphasic waves

High potential for SZs & convulsive / non-convulsive status epilepticus, So authors recommended the use of AEDs to manage these discharges. Sometimes, these discharges are not epileptogenic in nature

## PLEDs

- ✓ Term PLEDs was first used by Chatrian et al. in 1964, described as “periodic complexes occurring every 1-2 s, consisting of spikes or sharp waves followed by a slow wave.”
- ✓ Kuroiwa and Celesia(1980) defined PLEDs as complexes which occur at approximately regular intervals and which persist for greater than 10 min or are continuous in a specific behavioral state.
- ✓ Recurrence frequency – once in every 0.5 to 4 sec (usually recur at least every 2 sec)
- ✓ Metronomic periodicity - the recurrence of discharges at constant intervals
- ✓ Stating periodicity as metronomic or relative bears no relation to any particular etiology
- ✓ **Unaffected by** : Sensory stimuli, HV, REM/NREM sleep, Eye opening, IPS
- ✓ **Increased in frequency with** – Drowsiness
- ✓ **BGA** – Normal / low voltage delta activity
- ✓ **Duration of complexes** – 100-400 msec, later in evolution they get prolonged.
- ✓ Morphology varies over time
- ✓ Decreasing frequency of discharges over time
- ✓ Painful stimuli can result in an increase in the interval between the complexes
- ✓ Maximal on the side of the structural involvement
- ✓ 90% of the diagnosed PLEDs disappear within 4 weeks. (Schwartz et al. 1973)
- ✓ Chronic PLEDs described from 18 months to 20 years (Westmoreland et al 1986)
- ✓ Recurrent PLEDs also described in patients with TIAs and symptomatic epilepsy.

## **PLEDs – Etiologies**

PLEDs are usually a response to an acute process. Stroke, infections, tumors, metabolic conditions –majority of causes.

PLEDs occur at approximately regular intervals and persist for greater than 10 min or are continuous in a specific behavioural state

## **Pathophysiology**

A nonspecific result of acute partial and transient functional denervation in a localized area of the cortex Disappearing of PLEDs – cells would either Recover and respond normally or Die after a period of time, no longer responding.

## **PLEDs may be sub classified into:**

PLEDs-proper and PLEDs-plus

Low amplitude rhythmic discharges (RDs) closely associated in time and in spatial distribution to inter-ictal epileptiform discharges are not seen in scalp EEGs of patients with non-periodic focal epileptiform discharges (NPEDs) but they are unexpectedly common in patients with periodic lateralized epileptiform discharges (PLEDs). A classification of PLEDs into PLEDs Proper (PLEDs without RDs), and PLEDs Plus (PLEDs with RDs) is proposed. Such a classification is useful for an easier appreciation of PLEDs' pleomorphism. It underscores the changing periodicity of PLEDs and allows for a more inclusive definition of the phenomenon than the one reported by the literature. It also emphasizes the importance of recognizing RDs in scalp EEGs as transitional anomalies intercalated between inter-ictal PLEDs and ictal seizure discharges, analogous to those observed by Ralston in animal models. Indeed, the occurrence of recorded seizures is higher in patients with PLEDs Plus than in those with PLEDs Proper or NPEDs.

## Reiher's classification

PLEDs proper (without rhythmic discharges)

- ✓ Class I - aperiodic, throughout
- ✓ Class II - metronomic, intermittent
- ✓ Class III - metronomic, throughout

PLEDs plus (with rhythmic discharges)

- ✓ Class IV - brief RDs < 1 sec
- ✓ Class V - prolonged RDs

### Class I - aperiodic, throughout

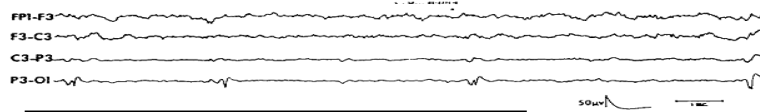

### Class II metronomic, intermittent

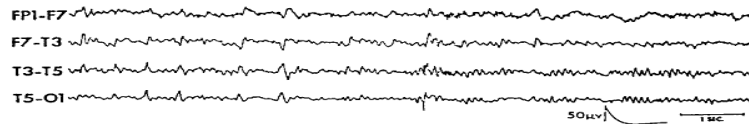

### Class III - metronomic, throughout

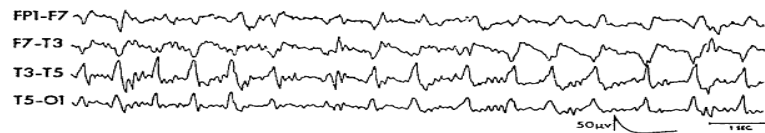

### Class IV

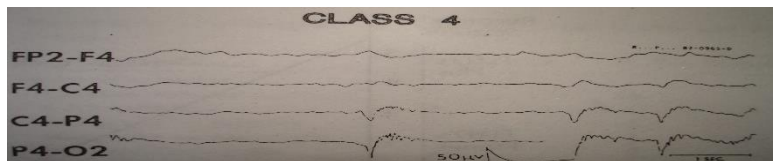

Brief RDs < 1 sec

### Class V

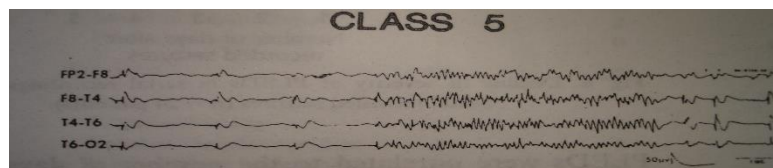

Prolonged RDs

NOTE:

EEG Typically fluctuating between PLEDs-proper and PLEDs – plus, indicating high seizures risk, PLEDs plus are less common in chronic lesions

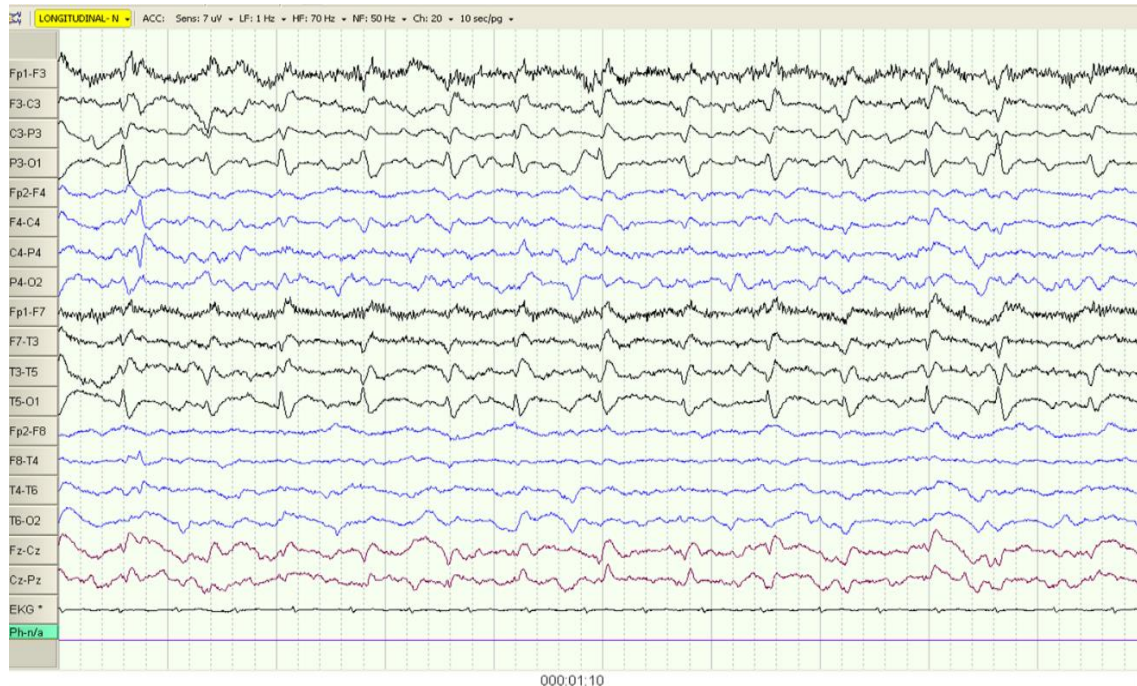

### **PLEDs - Evolution**

With time PLED plus evolve into periodic PLEDs (class 2 and 3) & then into aperiodic PLEDs (class 1). This transformation is also accompanied by a decreasing frequency of clinical seizures. Usually disappears within 2-3 weeks. Discharges → ↓ Amplitude, ↓ Repetition rate. PLEDs may change to seizures, isolated high voltage slow waves with delta or theta activity, sporadic spikes or sharp waves, Hypsarrhythmia in infants. May persist as chronic PLEDs, Recurrence of PLEDs – Recurring pathology e.g. TIA.

### **NOTES**

- ✓ Obtundation in 95% of PTs
- ✓ Focal seizures & focal neurological signs - 80%
- ✓ Epilepsia partialis continua – 30%
- ✓ SZs are not usually generalized
- ✓ 20% - comatose
- ✓ 80% - impaired consciousness
- ✓ Prognosis depends on the underlying etiology
- ✓ The worst prognosis noted for acute severe stroke

## Bilateral and independent Periodic lateralized epileptiform discharges

### BIPLEDs

- ✓ Seen in both hemispheres
- ✓ Independent
- ✓ Asynchronous
- ✓ Pattern is less common than PLEDs, Highly associated with SZs, Typically associated with acute structural lesions, with or without metabolic disturbances

### Cerebral Bigeminy

- ✧ 2 separate foci are present in the same area of an hemisphere
- ✧ Alternating morphology of these 2 ipsilateral PLEDs

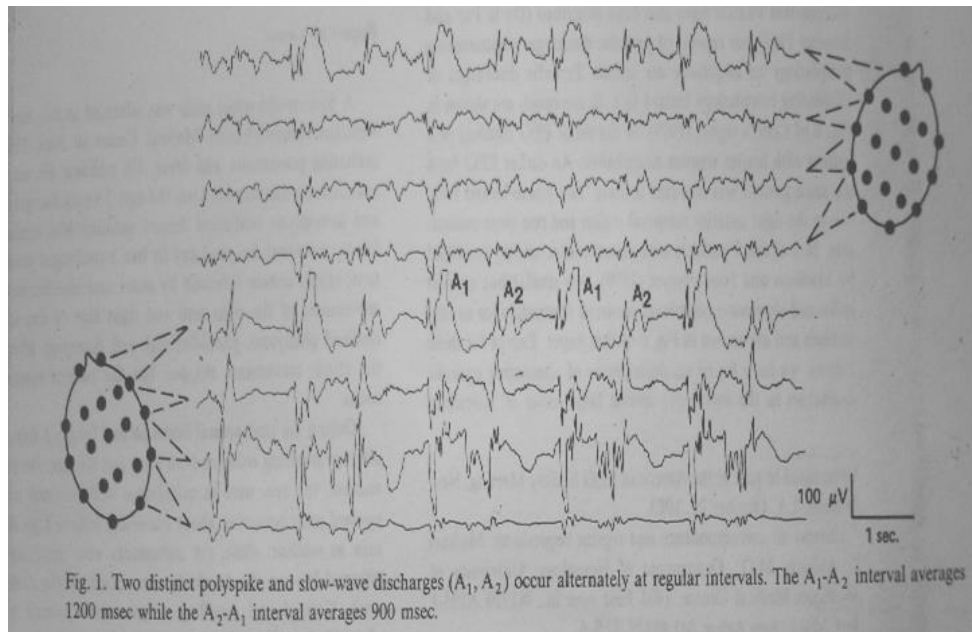

## Multifocal PLEDs

- ✧ 3 or more independent foci of PLEDs located over both hemispheres.
- ✧ 3 foci are also called TriPLEDs.
- ✧ Detection may be facilitated by use of Laplacian montages
- ✧ Reflect severe brain dysfunction and are associated with a significant mortality rate

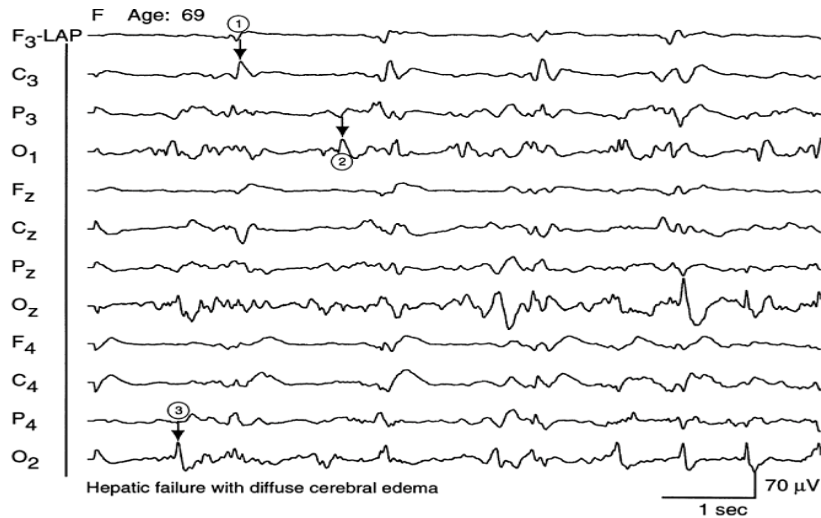
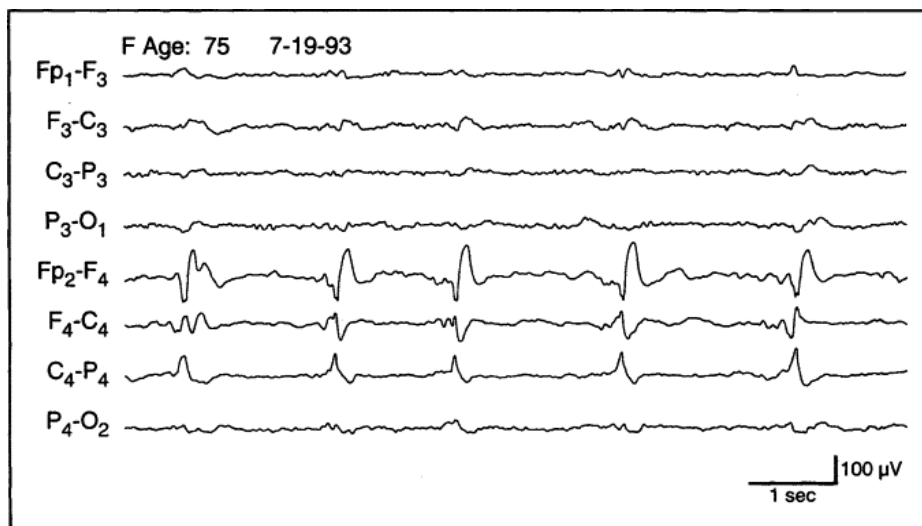

Fig. 1. Typical example of multifocal PLEDs (arrows) using the Laplacian montage, recorded from a 69-year-old woman with liver failure, sepsis, and hypoxia. Focus 1 (C<sub>3</sub>) occurring every 1.5 s; focus 2 (O<sub>1</sub>) occurring every 0.5–1 s; focus 3 (O<sub>2</sub>) occurring every 0.5 s.

From Lawn et al. Clin Neurophysiol 111:2125-2129, 2000.

## PEDIMs

- ✧ Periodic epileptiform discharges in the mid line.
- ✧ Association with underlying stroke & SZs
- ✧ Other than location, this activity has the same characteristics as PLEDs.



## **Benign EEG variants and patterns**

Benign patterns with 'epileptiform morphology abnormalities'

### **Small sharp spikes/BSSS**

Small sharp spikes (SSS) the original name also have been referred as 'benign sporadic sleep spikes'(BSSS) and 'benign epileptiform transients of sleep' (BE'TS); The BSSS are mainly seen in adults during drowsiness and light sleep. They are usually of low amplitude, usually less than 50uV and of short duration, less than 50 ms. The waveform consists of single monophasic or biphasic spikes with abrupt ascending limb and steep descending limb. The BSSS may have a single after coming slow wave component or may be associated with dip in background. They are best displayed in the temporal and ear leads.

### **Wicket spikes**

Wicket spikes occur either in brief runs or as isolated transients. It look like an arch. They are not accompanied by a slow wave. They occur over the temporal areas and may be unilateral or bilateral. Wicket spikes are seen best during stage I and II sleep, although they may rarely occur on wakefulness.

### **14 and 6Hz positives spikes**

The pattern consists of bursts of comb shaped waves having a frequency of 13 to 17Hz and/or 5 to 7Hz. The pattern is seen generally over the posterior temporal region and adjacent areas on one or both sides during the sleep. The sharp peaks of the wave are surface positive.

### **6 Hz spike and waves (Phantom spikes)**

This pattern consists of brief burst of 5 to 7 Hz spike and wave complexes. The spikes are of very small in amplitude and much smaller than the waves. The discharges, which are usually bilateral with frontal or occipital dominance, may occur during wakefulness and sleep, but it is seen mostly in drowsiness.

## **Rhythmic patterns**

### **Rhythmic Midtemporal Theta of Drowsiness (RMTD)**

This pattern consists of runs of sharply contoured theta activity. It may last for several seconds without significant change in frequency of the waves. They occur mainly in midtemporal area, although the activity may spread to the more anterior and posterior temporal areas and to the parietal regions.

### **Subclinical Rhythmic Electroencephalographic Discharges of Adults (SREDA)**

This pattern is reported to occur mostly during drowsiness in adults. Often the discharges starts with a sharp or slow wave of high amplitude and is followed by build of sharp waves to a sustained frequency of 4 to 7 Hz. The activity may last for several seconds to minutes and end abruptly. The most common areas to involved includes temporal and parietal regions

## **EEG Recording**

The EEG recording can last from anything between 15 minutes to 1 hour or longer depending on the situation. Typically the patient will be lying down or sitting relaxed in a chair. Most of the recording is taken with the eyes closed, although the patient will be frequently asked to open them for short periods,

Most patients will be asked to carry out a period of deep breathing for approximately 3 minutes. This may produce some abnormal activity, which would not be seen while the patient is relaxed. The physiological effect of deep breathing is to increase the amount of carbon dioxide (Co<sub>2</sub>) being removed from the bloodstream. This fall in Co<sub>2</sub> produces a fall in blood pressure and at the same time blood vessels in the brain become constricted. This reduces blood flow and the delivery of oxygen and glucose to the brain. This may turn to produce some abnormal brain activity not seen in the resting record.

Photic stimulation is also carried out. A strobe lamp is placed 30cm from the patient's eyes. Brief flashes of light (5-10 seconds in duration) at a number of different flash frequencies are delivered to the patient with both eyes open and eyes closed. A continuous flash with increasing and decreasing flash frequencies is sometimes used. Some patients who are sensitive to flashing lights may show abnormal activity in the EEG.

Throughout the test the technologist is constantly annotating the record with any patient movements, or tasks that they are carrying out. Other signals may also be recorded in conjunction with the EEG such as- heart rate (ECG), respiration and eye movements (EOG).

## **EEG Analysis**

The EEG reports consist of a number of different sections. The technologist may prepare a report describing the type of activity seen in the record together with changes produced by deep breathing and photic stimulation. They will also comment on the patient's state during the recording. The physician will then interpret these changes with regard to the medical problem being investigated.

With an increase in the number of long recordings being carried out, many departments make use of detection algorithms such as spike and seizure detection. Although it is still necessary for the clinician to review the complete record, such programs will mark and highlight sections of interest. The most efficient method of implementing these algorithms is for the detection to be carried out on-line.

Other methods of analyzing EEG data include Power Spectrum Analysis. A Fast Fourier Transform (FFT) is performed on sections of EEG data to determine the power content of four main frequency bands. The resulting waveforms can be displayed as a brain map, which will show the scalp distribution of the power within each frequency band. The amplitude of the different waveforms at a single point can also be displayed in a similar format. This type of display provides a more objective analysis of the EEG activity compared to a subjective visual analysis by a physician.

## **ACTIVATION PROCEDURES**

Various activation procedures can elicit or enhance certain normal as well as abnormal activity in the EEG. The following are the most commonly used activation procedures performed in most of the laboratories.

### **Hyperventilation**

Hyperventilation is perhaps the most widely used activation procedures in EEG laboratories. This is a very simple and relatively safe procedure, consisting of three to five minutes deep breathing at the rate of about 20 per minute. During hyperventilation technologist should carefully observe the patient to detect the occurrence of absence seizure.

The normal response to the hyperventilation consists of the occurrence of symmetrical slowing on both sides. Although this slow activity may be diffuse slow wave activity. The major biochemical influence of hyperventilation is a drop in carbon dioxide content of the blood (hypocarbica). It leads to vasoconstriction. This presumably alters the metabolic rate of the neurons and leads to the slow activity.

The most striking EEG abnormality seen during hyperventilation is the 3 Hz spike and wave discharges often brought on in patients with absence seizures. It is preferable to avoid in patients with recent stroke or subarachnoid hemorrhage, myocardial infarction, chronic obstructive pulmonary disease and other conditions causing difficulty in breathing. Sometimes, other type of epileptiform abnormality, such as generalized spike and wave discharges or even focal spikes# may be brought on by hyperventilation

### **Intermittent Photic Stimulation**

Visual stimuli are perhaps one of the most effective means of stimulation of the brain. Stroboscopes otherwise known as Photic stimulators are used for the purpose. Single or continuous bright flashes of light at frequencies ranging from 1 to 50 flashes per second are used. Flashes of duration 10 micro second with an intensity of 1.5 million foot candles are routinely given. The flash lamp is positioned 30cm in front of the eyes. Each flash is presented for duration of 10 seconds, and the eyes are kept closed in first 5 seconds and open in the next 5 seconds.

Photic stimulation is most valuable in documenting photosensitivity, which has a correlation with primary generalized epilepsy. The flash lamp is positioned 30 em in front of the eyes. Each flash rate is presented for a duration of about 10 seconds, and the eyes are kept closed in the first 5 second and are kept opened in the next 5 seconds. The IPS should be stopped if photo paroxysmal responses are obtained in order to avoid the of seizure.

### **Sleep deprivation and Sleep**

In the last several years sleep recording have become routine procedure in many EEG laboratories for eliciting epileptiform abnormalities. The augmenting effect of sleep is both in generalized as well as in focal epilepsies, especially in patient with temporal lobe foci. In the majority of patients with epilepsy a generalized epileptiform discharges may become may be evident only during sleep. A dramatic increase in spike discharges during drowsiness and light sleep is a characteristic feature of benign rolandic epilepsy.

### **Pharmacological Activation**

A number of pharmacological agents have been used to induce epileptiform activities in patients with seizure disorder, the purpose being to determine whether one is dealing with a primary generalized or a focal onset seizure. It is not commonly employed in routine EEG although it finds its place in Electrographic.

## **EEG Applications**

One of the major roles of EEG is as an aid to diagnose epilepsy. Abnormal patterns such as spikes, sharp waves and/or spike and wave complexes can be seen. The type of activity and the area of the brain that it is recorded from will assist the physician in prescribing the correct medication for that type of epilepsy.

Patients with epilepsy that cannot be controlled by medication will often have surgery in order to remove the damaged tissue. The EEG plays an important role in localizing this tissue. Special electrodes can be inserted through the cortex or alternatively a grid of electrodes placed directly on the surface of the cortex. These recordings, often called Long Term Monitoring for Epilepsy (LTME), can be carried out for periods ranging from 24 hours to 1 week. The EEG recorded will indicate which areas of the brain should be surgically removed.

EEG studies can also be used in patients who are deeply unconscious, to distinguish between brain death and possible reversible conditions.

Electro cerebral inactivity (ECI) or electro cerebral silence (ECS) is defined as no brain activity over 2-1 uV in amplitude when recording from electrodes on the scalp that are 10 cm or more apart.

Using the 10/20 International System of electrode placement, the average distance between electrodes in an adult is 6 to 6.5 cm. Activity recorded using these distances and at a normal display sensitivity may suggest ECS. However if the some activity was recorded using longer inter-electrode distances, some activity might be seen. Therefore some double distance electrode linkages are recommended for example FP1-C3, F3-P3, and C3-O1 etc.

Display sensitivities of a minimum of 2 uV/mm are required. However digital EEG systems have the added advantage of having sensitivity values of 1.5 and 1uV/mm. This 50-100 % increase in sensitivity will allow a more confident assessment of the presence or absence of a 2uV signal. The EEG is also used to investigate other conditions that may affect brain function such as strokes, brain injuries, liver and kidney disease and dementia.

# **EEG MONITORING IN INTENSIVE CARE SETUP**

## **EEG MONITORING IN INTENSIVE CARE SETUP**

EEG provides a unique way of monitoring cerebral function in the Intensive Care unit and it is useful both for recording short and long acting events. Typically, epileptic spikes may last for a fraction of seconds, but recordings for many hours, for example during sleep cycles may also give important information. Recordings lasted for many days also be useful, to reflect slow trend changes in the EEG.

One basic requirement for an EEG monitor in the ICU is that has to present the original EEG on a monitor display and also has to provide a paper printout. Another additional benefit would be to have the system continuously store signals. This would allow access to previously stored EEGs for inspection if unexpected, rapid changes, such as seizures, should occur.

It would be beneficial for the ICU clinician's daily work to understand the tasks of EEG. It would be even better if the clinicians were able to identify typical EEG patterns such as physiological activity, pathologically slowed rhythms, seizure activity in its various forms, periodic patterns and burst suppression. It discusses the utilization of the EEG monitoring comatose patients in the ICU .The selected aspects include reactivity, periodic patterns and burst suppression that may characterize an EEG in the ICU.

Recording of an EEG should be utilized more in the monitoring of comatose ICU patients. The EEG recording, repeated at intervals, can help with broad diagnostic categorization. In special clinical situations, for example in monitoring of the effectiveness of status epilepticus treatment, continuous monitoring of EEG could be deemed obligatory. In the assessment of the clinical importance of EEG patterns, clinical picture, age, etiology, acuity, and the integrity of the brainstem reflexes must be taken into consideration.

Another factor is that special EEG patterns, like triphasic waves, may suggest Metabolic disturbances, which could be caused by liver dysfunction or toxic substances. From clinical and neuropsychological point of view, it is important to test reactivity of EEG. In general reactivity can be considered as a feature of the lighter stages of coma. However, even during deep anesthesia, with EEG at the burst suppression level, reactions to minor somatosensory, auditory, or visual stimuli can sometimes be seen.

# **Prolonged Video EEG Monitoring**

## **Introduction**

Video-electroencephalography (VEEG) monitoring provides long-term recording of the electroencephalogram (EEG) and time locked video of the patient in a dedicating recording room. It is the most definitive method for the differentiation of seizure versus nonepileptic events, classification of seizure types and localization of seizure onset. The clinical features helpful in distinguishing between temporal and extra temporal complex partial seizure. VEEG has an important role in the pre -surgical evaluation of patients with medically refractory epilepsy.

Scalp disk electrodes placed according to 10/20 system of placement. Special electrodes may be placed when indicated (e.g.: anterior temporal electrodes, sphenoidal electrodes) At least 16 channels of EEG and one channel of EKG should be monitored. The events can be detected by patient's caregivers triggered an event signal, a trained EEG technologist who visually scanned the VEEG or a computer equipped spike and seizure detection programme. Samples of inter ictal EEG and events are identified and then reviewed.

Analysis of some paroxysmal events may suggest alternative diagnosis- including e.g.; syncope, psychogenic seizures, sleep disorders, paroxysmal movement disorder and other causes of episodically distributed behavioral surgical management.

## **Recording method**

### Facilities

A room, close friends or relatives, medical team

### Duration of monitoring

3 to 7 days

### Scalp electrodes

10-20 international electrode placement is used with T 1 and T2 electrodes located below F7-F8 or T3 -T4 positions. Some used T 1 &T2 electrodes to differentiate activity arising from the focus rostral to the sylvian fissure in the frontal lobe and an anterior temporal source. The maximal field of epileptiform activity in patients with complex partial seizure can be seen.

## **Ictal SPECT**

The Single Photon Emission Computed Tomography (SPECT) is a nuclear medicine tomographic imaging technique using gamma rays. SPECT shows distinctive and rapidly changing blood flow pattern at the time of seizure. The use of SPECT in epilepsy centers on localization of the epileptogenic zone usually performed so that surgical treatment can be carried out. Most work has been carried out using tracers of regional cerebral perfusion. Early work concerned the inter-ictal period, but increasingly postictal and ictal studies are being carried out.

Usually the gamma-emitting tracer used in functional brain imaging is  $^{99m}\text{TcHMP AO}$  (hexamethyl propylene amine oxime).  $^{99m}\text{Tc}$  is a metastable nuclear isomer which emits gamma rays which can be detected by a gamma camera. When it is attached to HMPAO, this allows  $^{99m}\text{Tc}$  to be taken up by brain tissue in a manner proportion to brain blood flow, in turn allowing brain blood flow to be assessed with the nuclear gamma camera.

## **Neurotechnologist's role in ictal SPECT**

The tracer is injected to the patient for an ictal SPECT, immediately at the onset of the seizure. Some patients have electro-graphical onset, before the clinical features begins. So the procedure should be done during VEEG monitoring. As the seizure begins the technologist give instruction to the nurse for injection of the tracer.

## **Sphenoidal electrode placement**

These electrodes are used to record discharges from the anterior tip of the temporal lobe. Electrodes are usually made from thin, straight insulated stainless steel wire about 50 mm long and 0.5 mm diameter, with a small uninsulated ball at the tip. Sphenoidals are introduced via a needle cannula into the temporal and masseter muscle with insertion point between zygoma and sigmoid notch of the mandible. Penetration is directed slightly anterior so that the tip rests lateral to the foramen ovale at the greater wing of the sphenoid. Infection is risk but very rare. Sphenoidal electrodes wire can stay for several days for prolonged recording. The activity from the mesial and basal temporal cortex can be recorded without too much artifact.

## Invasive monitoring

Patients may require invasive monitoring when the results of noninvasive methods such as scalp EEG, VEEG and MRI are conflicting. Placing sphenoidal electrode under fluoroscopy directly below the foramen ovale resulted in better detection of inter-ictal and ictal epileptiform activity of mesial, basal-temporal origin. Several types of intracranial recording electrodes. Such as subdural strip electrode, grid electrodes, epiduralelectrodes, intra-cerebral depth electrodes or combination of each are used.

- ▶ ECOG electrodes are sterile, disposable stainless steel, carbon tip, platinum, or gold ball electrodes.
- ▶ Commonly we are using strip, grid depth electrodes.
- ▶ Each contact with 5 mm diameter and 1 or 0.5 cm inter electrode spacing.

### Grid electrodes

They are transparent, flexible, and numbered at each electrode contact. Standard spacing between grid electrodes is 1 cm; individual electrodes are typically 5mm in diameter.

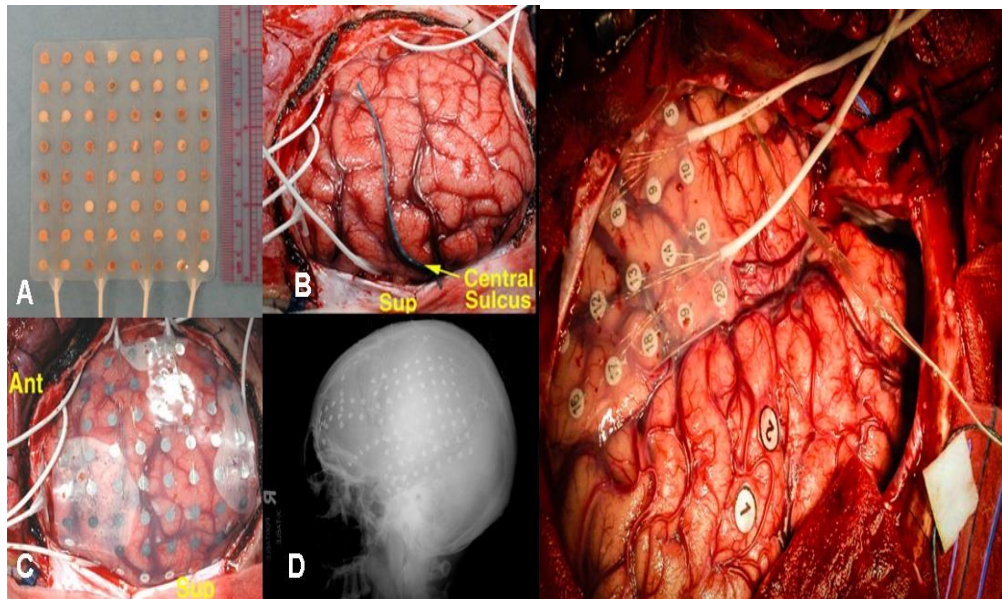

## Strip electrodes

contacts are arranged in a single row.  
There are 4 contact , 6 contact , 8 contact and 10 contact strips

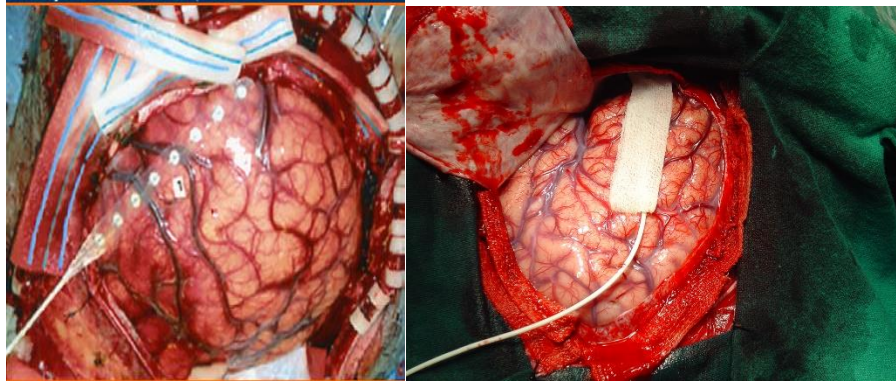

## Depth electrodes

Depth electrodes are arrays of electrodes designed for introduction directly into the substance of the brain by a neurosurgeon. They are used to detect and localize activities not visible by scalp EEG recording. Depth electrodes are composed of fine array of thin stainless steel, platinum or gold insulated wire of different ending in insulated tips. The depth electrodes are implanted stereo-tactically, free hand, or with x ray guidance, under sterile protocol. Electrodes are remaining in place for several days or weeks. Amygdala, hippocampus, orbitofrontal cortex and supplementary motor areas of frontal lobe are the popular placement targets.

The depth EEG clearly increases the ability to detect and localize epileptiform activity in selected patients, but it has disadvantages. All the brain sites cannot be studied with this technique, resulting in possible sampling error. It is used to record activity from deeper structures such as the hippocampus.

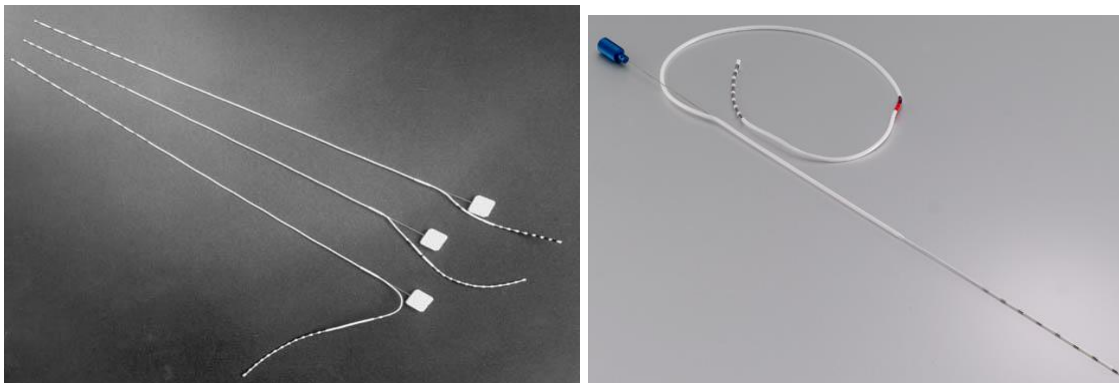

## Subdural electrodes

Subdural electrodes are designed to be in contact with cortex of awake, behaving patients for a few days or weeks. The goal of subdural recording is localizing the seizure foci in relation to important functional areas of the brain. Areas of the cortex involved in sensorimotor, speech, reading, or cognition are identified by stimulation. In order to study a large area of the cortex, subdural grids may be assembled in an approximately hand - sized array, with up to eight rows and eight columns of the electrodes. These electrodes are usually 3 mm disks fabricated from stainless steel or platinum. Electrodes are embedded in a sheet of flexible plastic, with center to center electrode separation of 1 mm. grids may be cut to size during implantation.

## Epidural electrodes

Epidural electrodes in single or double row strips are less invasive than subdural grids (they can be placed through a burr hole) and often provide important information about seizure foci. Because a smaller area is covered, the true foci. Because a smaller area is covered, the true focus is likely to be in the field of recording.

## Ictal onset(Invasive monitoring using depth electrode)

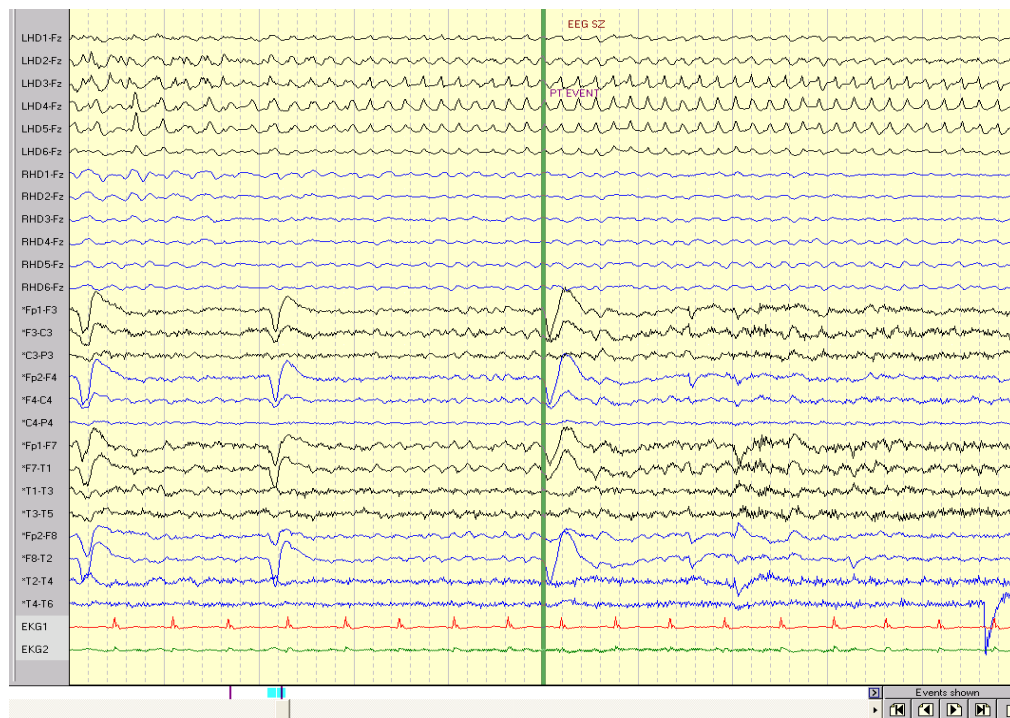

## EEG SZ

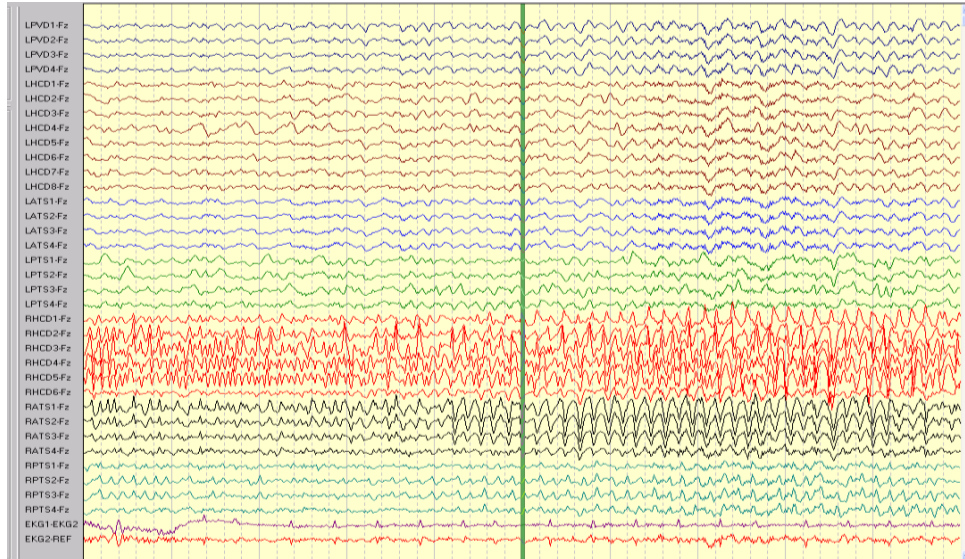

## Ictal rhythm

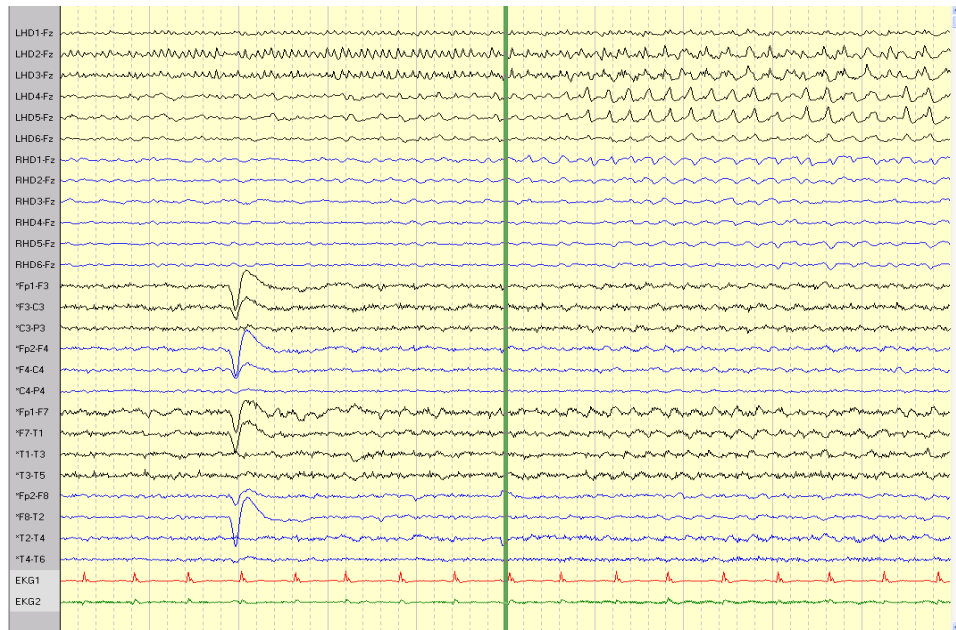

## **Cortical stimulation mapping**

**Cortical stimulation mapping** (often shortened to CSM) is a type of electrocorticography that involves a physically invasive procedure and aims to localize the function of specific brain regions through direct electrical stimulation of the cerebral cortex. It remains one of the earliest methods of analyzing the brain and has allowed researchers to study the relationship between cortical structure and systemic function. Cortical stimulation mapping is used for a number of clinical and therapeutic applications, and remains the preferred method for the pre-surgical mapping of the motor cortex and language areas to prevent unnecessary functional damage. There are also some clinical applications for cortical stimulation mapping, such as the treatment of epilepsy.

### **Procedure**

Cortical stimulation mapping is an invasive procedure that has to be completed during a craniotomy. Once the dura mater is peeled back, an electrode is placed on the brain to test motor, sensory, language, or visual function at a specific brain site. The electrode delivers an electric current lasting from 2 to 10 seconds on the surface of the brain, causing a reversible lesion in a particular brain location. This lesion can prevent or produce a testable response, such as the movement of a limb or the ability to identify an object. The electric current from the electrode stimulates whatever function that site in the brain is responsible for, in essence telling the surgeon or examiner what a specific locale in the brain does.

Electrodes are usually made of stainless steel or platinum-iridium embedded in a silastic material, and are usually circular with diameters of 2 to 3 mm. Electrode positioning varies from patient to patient, and electrodes can come in rows, in a grid array, or can be individually arranged. The number of electrodes necessary and their exact spatial arrangement is often determined in the operating room. Cortical stimulation mapping allows electrodes to be placed in exact locations to test brain function and identify if stimulation of the brain location causes a functional impairment in the patient. CSM can be completed using anesthetized patients or awake patients.

Electrodes can either be placed directly on brain areas of interest or can be placed in the subdural space of the brain. Subdural electrodes can shift slightly and can be affected by cerebrospinal fluid in the subdural space, which could interfere with the current used to stimulate the brain from the electrodes and possibly cause shunting and dissipate the current, making the stimulation's effect less accurate. However, an advantage of subdural electrode grids is that they can be left in the brain for multiple days, and allow functional testing during stimulation outside the operating room.

Current levels and density are an important consideration in all cortical stimulation mapping procedures. Current density, that is the amount of current applied to a defined area of the brain, must be sufficient to stimulate neurons effectively and not die off too quickly, yet low enough to protect brain tissue from damaging currents. Currents are kept at levels that have been determined safe and are only given as short bursts,

typically bursts that slowly increase in intensity and duration until a response (such as a muscle movement) can be tested. Current intensity is usually set around bursts of 1 mA to begin and gradually increased by increments of 0.5 to 1 mA, and the current is applied for a few seconds. If the current applied causes after discharges, nerve impulses that occur after stimulation, then the levels are lowered. Studies on patients who have received cortical stimulation mapping have found no cortical damage in the tested areas.

The different types and administration techniques for anesthesia have been shown to affect cortical stimulation mapping. CSM can be done performed on awake patients, called an awake craniotomy or in patients who have been placed under general anesthesia. If the patient is under general anesthesia, the depth of the anesthesia can affect the outcome because if the levels of muscle relaxation are too high due to neuromuscular blocking drugs, then the results from the mapping can be incorrect. For the awake procedure there are different considerations for patient care that the anesthesiologist must take into account. Rather than simply ensuring that the patient is asleep, the doctor can follow what is called the asleep-awake-asleep technique. In this technique the patient is anesthetized using a general anesthesia during the opening and closing portions of the procedure, but during the interim the patient is maintained utilizing local anesthesia. The local anesthesia techniques can be either a local field block or a regional nerve block of the scalp. The more common technique for the awake craniotomy is conscious sedation. In conscious sedation, the patient is only sedated during the opening and closing process, but never fully anesthetized, eliminating the need for breathing tubes, lessening the chances of complications, and lessening the chances of problems with motor response. Patients who undergo the procedure with an awake craniotomy instead of general anesthesia have better preservation of language function, a prediction of their seizure-free outcome based on corticography, a shorter hospitalization (which corresponds to a reduced cost of care), a decreased usage of invasive monitors, and decreased number of postoperative complications due to anesthesia such as nausea and vomiting

### **Clinical Application in Epilepsy.**

CSM is an effective treatment for focal epilepsy and bilateral or multiple seizure foci. It is an effective treatment option when resective surgery to remove the affected area is not an option, generally seen with bilateral or multiple seizure foci. CSM is routinely utilized for patients with epilepsy in order to pin point the focal point of the seizures. It is used once there is a testable hypothesis regarding brain location for the epileptogenic zone, determined through a less invasive procedure, electroencephalography. Once the focal point of the seizures is determined, this information allows aids neurosurgeons with knowing what portions of the brain could potentially be resected without any negative post-operative neurological deficits.

CSM will be considered for a patient with epilepsy when two conditions are met: the trial of anti-epileptic drugs has not controlled seizures and there is a likelihood that the surgery will benefit the patient. Due to the nature of the procedure, CSM is only utilized after noninvasive procedures have not been able to fully localize and treat the patient

The invasive electrodes are stereotaxically placed electrodes or a subdural strip or grid electrode Utilizing the information obtained through CSM, limited resection of epileptogenic brain can be performed. For focal epilepsy, resective surgery is one of the mainstay treatment options for medication resistant epilepsy. Through the technique of CSM, generally using awake craniotomies, the neurosurgeon has the ability to monitor the functioning of the patient during the resection and stimulation of the brain.

## **Protocol For Cortical Stimulation**

- Stimulation parameters
 

Pulse Rate	50Hz
Pulse Duration	0.2Milliseconds (200Microseconds)
Train Duration	1-5 Seconds
Strength of current	Start at 2.0mA, Increment at 0.5-1.0 mA, upto 10mA
Channels Stimulated	Bipolar, between two neighboring channels
  
- Stimulation End points
  - Symptoms
    - Somatosensory suggest sensory area, but stimulate 0.5 to 1.0 mA higher to see if it is motor area, unless the sensation is intolerable or after discharge is already induced
    - Visual Visual function
    - Aura suggest ictal zone
    - Cognitive, Affective uncommon but may suggest cognitive or limbic areas or “psychological” reaction
  
- Signs
  - Motor may appear as negative(loss of posture) or positive(twitch)
  - Speech Suggest language functions
  
- After discharge or seizure Do not stimulate at the same strength
- Maximum strength 10 mA (some centers goes up to 15mA)
  
- Important Pointers
  - General pointers
    - Do the study at the conclusion of video EEG monitoring and with AED coverage
    - Counsel patient before start of procedure to let you know if anything is felt, &where it is felt, including any sensation.

# **ELECTROCORTICOGRAPHY**

## Electrocorticography

It is one of the first important applications of intraoperative recording of cerebral electrical activity, later, depth recordings were made acutely during the course of epilepsy. Electrocorticography during epilepsy surgery has been performed for several years. In particular this is for the tailored resections both temporal and extra temporal in order to identify the epileptogenic zone. Techniques for pre-operative localization of motor and sensor gyri with electrical cortical stimulation and SEP recordings with subdural strip electrodes have been developed and are also used in the resection of intracranial tumors close to these eloquent cortical regions.

Pre-operative nerve stimulation is used in the neurosurgical reconstruction of peripheral nerve and plexus brachialis lesions. SEP recordings in patients operated for tethered spinal cord, scoliosis or intraspinal tumors monitor the spinal cord function. The method of pre-operative electrical cortical stimulation in spinal cord monitoring will be introduced shortly. Dorsal root stimulation is used during the dorsal rhizotomy procedure to reduce spasticity in children with cerebral palsy and spastic diplegia. The function of the facial nerve is monitored in the resection of acoustics neurinoma. Ensure surgery will not result in disabling neuro-psychological deficits. The appearance and reproducibility of potentials recorded intraoperative is affected greatly by type & level of anesthesia, blood pressure, temperature & other physiological variables.

## Purpose of Intraoperative monitoring

To preserve function and prevent injury to vital neuronal structure at the time when clinical examination is not possible.

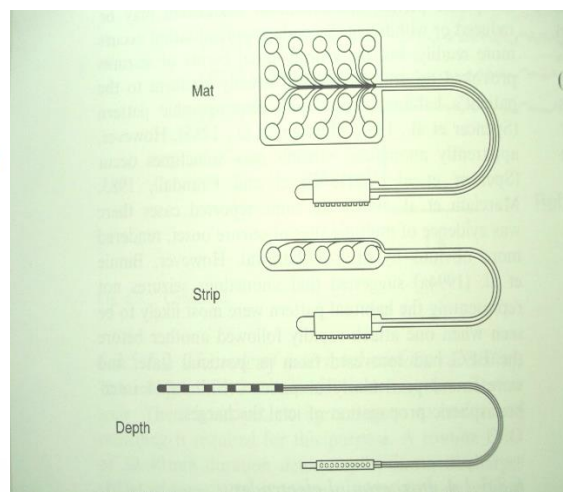
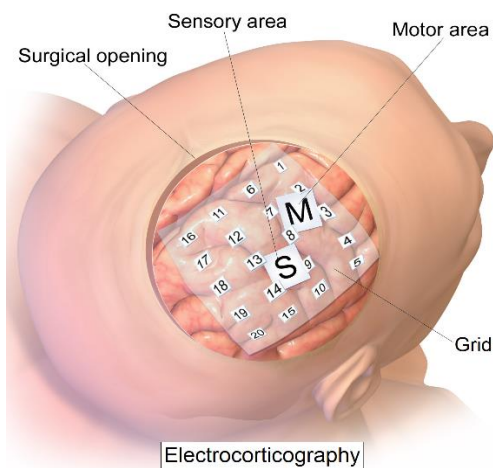

## RIGHT ATL+AH (20 GRID)



4 contact Strip



4 contact Depth(Amygdala)

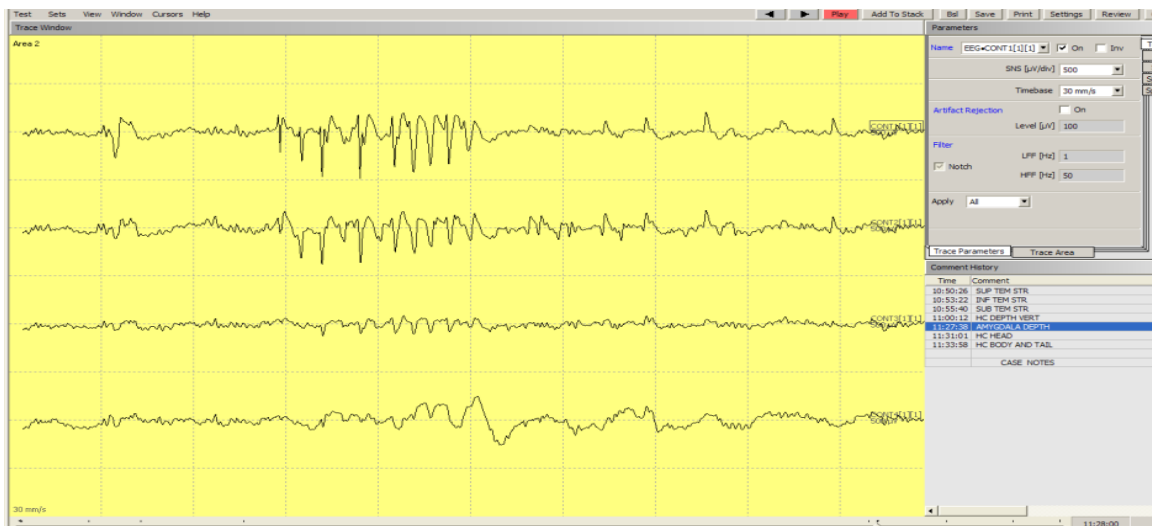

Evoked potential monitoring includes somatosensory evoked potentials (SSEP), brainstem auditory evoked potentials (BAEP), motor evoked potentials (MEP), and visual evoked potentials (VEP). Electromyography (EMG) also is used extensively during operative cases. Scalp electroencephalography (EEG) provides data for analysis in SSEP, BAEP, and VEP. Scalp EEG also can be used to monitor cerebral function during carotid or other vascular surgery. In addition, EEG recorded directly from the pial surface, or electrocorticography (ECoG), is used to help determine resection margins for epilepsy surgery, and to monitor for seizures during electrical stimulation of the brain carried out while mapping cortical function.

The use of functional mapping of the white matter together with cortical mapping allowed the authors to optimize the benefit/risk ratio of surgery of low-grade glioma invading eloquent regions. Given that preoperative fiber tracking with the aid of neuroimaging is not yet validated, we used intraoperative real-time cortical and subcortical stimulations as a valuable adjunct to the other mapping methods.

## **Intra operative SSEP during epilepsy surgery**

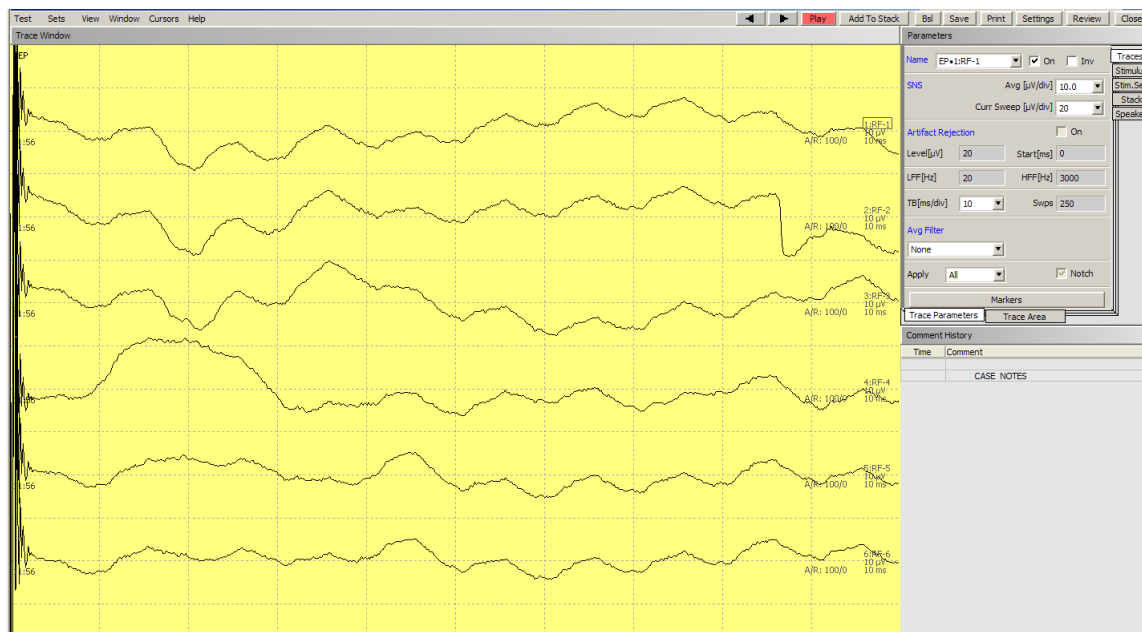

# **POLYSOMNOGRAPHY**

# **POLYSOMNOGRAPHY**

## **Introduction**

A polysomnogram consists of a simultaneous recording of multiple physiologic parameters related to sleep and wakefulness. The interaction of various organ systems during sleep and wakefulness is also evaluated.

Polysomnography (PSG) is used to evaluate abnormalities of sleep and/or wakefulness and other 'physiologic disorders' that 'have-an impact on-or -are' related to sleep and/or wakefulness.

By international standards, a polysomnogram must have a minimum of 4 neurophysiologic channels.

- One electroencephalography (EEG) channel (central with an ear reference provides the best amplitude) to monitor sleep stage
- Two electrooculogram (EOG) channels to monitor both horizontal and vertical eye movements (electrodes are placed at U1e right and left outer canthi, 1 above and 1 below the horizontal eye axis)
- One electromyography (EMG) channel (usually chin or mentalis and/or submentalis) to record atonia of rapid eye movement (REM) sleep

Other parameters often monitored include the following:

- Additional EEG channels, particularly in patients with sleep-related epilepsy
- Additional EMG channels, particularly anterior tibialis, to detect periodic limb movements of sleep
- Airflow
- Electrocardiography
- Pulse oximetry
- Respiratory effort
- Sound recordings to measure snoring

Optional parameters include the following:

- Continuous video monitoring of body positions
- Core body temperature
- Incident light intensity
- Penile tumescence
- Pressure and pH at various esophageal levels

In 1992, the Office of Technology Assessment of the Agency of Health Care Policy and Research recommended, in an evidence-based assessment. Two tests have been studied sufficiently. Both tests are performed in a sleep laboratory.

- Overnight polysomnography (PSG) is an overnight recording of the patient's sleep.
- Multiple sleep latency testing (MSLT) records multiple naps throughout a day.

Standard sleep studies usually include both tests, PSG (may be performed over several nights} followed by MSLT the next day. Limitations usually stem from the fact that recording conditions may not reflect what happens during a regular night in the patient's home.

Although diagnosing a sleep problem on the basis of a recording over a single night is common practice, some authorities caution that more than 1 night of recording may be necessary, so the patient may become comfortable with unfamiliar surroundings and sleep more naturally. This effect is greatest on the first night in the sleep laboratory ("first night effect").

Sporadic events may be missed on a 1-night PSG. External factors that disturb the subject's sleep may be present in the home but absent from the controlled environment of the sleep lab. Patient preparation is important so that the patient sleeps naturally. Patient instructions include the following:

- Maintain regular sleep-wake rhythm
- Avoid sleeping pills • Avoid alcohol
- Avoid stimulants, including medications for narcolepsy
- Avoid strenuous exercise on the day of PSG testing

High costs and long waiting lists have prompted the exploration of alternative methods of evaluation. Although the following studies may have usefulness in specific clinical situations, Bloch concludes that their role compared to conventional sleep studies remains controversial.

- Ambulatory monitoring with portable equipment
- Daytime PSG

Simplified sleep studies with limited subsets of monitored parameters Automatic, computer-based systems often are employed in clinical and research settings. However, standard analysis still consists of tedious and time-consuming review and scoring of either paper tracings or recordings projected on a computer monitor.

Overnight parameters (e.g.: times of lights on/off, total time in bed, total sleep time) are collected. The overnight recording is divided into epochs of approximately 30 seconds. The standard EEG, EMG, and EOG recordings are evaluated, and the predominant stage of sleep then is assigned to the entire epoch.

Total time and relative proportion of the night spent in each of the 6 stages and in REM and non-REM sleep are calculated. Latencies to REM and slow-wave sleep (SWS) are reported.

Special neurophysiologic events (e.g.: epileptic events, intrusion of alpha into sleep, periodic activity of tibialis anterior) are reported. Respiratory activity (e.g., apneic or hypopneic episodes, oxygen saturation) is correlated with sleep stages. Other parameters such as body position, gastro esophageal reflux, bruxism, and penile tumescence are recorded. If a sleep apnea syndrome is diagnosed, a trial and titration of continuous positive airway pressure or a trial of an oral appliance may be undertaken, either in a partial-night or second-night PSG recording.

## **Dysomnias (disorders of initiating or maintaining sleep)**

- Circadian rhythm disorders
- Narcolepsy
- Idiopathic hypersomnia
- Inadequate sleep hygiene
  
- Sleep-related respiratory disorders
  - o Sleep apnea syndrome
  - o Upper airway resistance syndrome

## **Parasomnias**

- Disorders of arousal
  - Disorders of sleep-wake transition
  - Disorders that occur during REM sleep
    - o Nightmares
    - o REM behavior disorder
  - Medical-psychiatric sleep disorders
    - o Medical ~ Sleep-related asthma
    - o Psychiatric
      - Depression
      - Panic disorder
  - Neurologic- Sleep-related epilepsy
  - Others
    - o Bruxism
- Restless legs syndrome and periodic limb movement disorder

## **MSLT**

The Multiple Sleep Latency Test (**MSLT**) is a sleep disorder diagnostic tool. It is used to measure the time elapsed from the start of a daytime nap period to the first signs of sleep, called sleep latency. The test is based on the idea that the sleepier people are, the faster they will fall asleep.

## Continuous positive airway pressure (CPAP)

**Continuous positive airway pressure (CPAP)** is a form of positive airway pressure ventilator, which applies mild air pressure on a continuous basis to keep the airways continuously open in people who are able to breathe spontaneously on their own. It is an alternative to positive end-expiratory pressure (PEEP). Both modalities stent the lungs' alveoli open and thus recruit more of the lung's surface area for ventilation. But while PEEP refers to devices that impose positive pressure only at the end of the exhalation, CPAP devices apply *continuous* positive airway pressure throughout the breathing cycle. Thus, the ventilator itself does not cycle during CPAP, no additional pressure above the level of CPAP is provided, and patients must initiate all of their breaths.

CPAP typically is used for people who have breathing problems, such as sleep apnea. CPAP also may be used to treat preterm infants whose lungs have not yet fully developed. For example, physicians may use CPAP in infants with respiratory distress syndrome. It is associated with a decrease in the incidence of bronchopulmonary dysplasia. In some preterm infants whose lungs haven't fully developed, CPAP improves survival and decreases the need for steroid treatment for their lungs.

CPAP therapy utilizes machines specifically designed to deliver a constant flow of pressure. Some CPAP machines have other features as well, such as heated humidifiers. CPAP is the most effective treatment for obstructive sleep apnea, in which the mild pressure from the CPAP prevents the airway from collapsing or becoming blocked.<sup>[1]</sup>

Although delivery of CPAP through a nasal mask is the most common modality of treatment, other systems exist for interfacing with adults and children. Nasal CPAP is frequently used in infants though its use is controversial. Studies have shown nasal CPAP reduces ventilator time but an increased occurrence of pneumothorax was also prevalent. Oral masks and naso-oral masks are often used when nasal congestion or obstruction is an issue. Devices that combine nasal pressure with maxillary advancement devices (MAD) also exist.



# **NERVE CONDUCTION STUDY**

## **Introduction**

Nerves control the muscles in the body using electrical impulses. Whenever a muscle contracts (tenses up) in response to a signal from the brain, it produces an electrical discharge of its own. Electromyography (EMG) measures the electrical discharges made by the muscles. Nerve conduction studies measure how well individual nerves can transmit electrical-signals.

Measuring the electrical activity in muscles and nerves can help detect the presence, location and extent of diseases that can damage muscle tissue (such as muscular dystrophy) or nerves (such as amyotrophic lateral sclerosis). In the case of nerve injury, the actual site of nerve damage can often be located. EMG and nerve conduction studies are often done together to provide more complete information.

The myelinated nerve axon conducts impulses in a saltatory fashion i.e. depolarization occurs at the nodes. The currents are prevented from penetrating the membrane between the nodes in the normal nerve due to an isolating myelin sheath. This means that the impulse propagation is much faster than if there was a continuous depolarization. The conduction velocity is also dependent on the axonal diameter and the properties of the membrane. A normal axon conducts with a speed of 35-60 m/sec. The velocity is reduced if the myelin is defect due to pathological changes, if the ion- channels at the nodal areas are blocked or if the axon diameter is smaller than normal. It is also dependent on temperature.

When the correlation between neurophysiological and morphological parameters was established, the nerve conduction study become an important method used in, clinical routines. Such studies are performed in most EMG laboratories since the 1960's and have since then become more sophisticated, sensitive and specific.

This summary will give a brief update of the nerve conduction studies, which are performed in clinical routine today.

## **General guidelines for performing nerve conduction studies**

Before attempting nerve conduction studies on patients one must consider a number of factors. First, the patient must be aware of what to expect. In addition the tester must prepare the anatomical part to be tested and must understand the potential problems that could arise.

1. Explain the procedure to the patient. It is important to explain the procedure to the patient in the simplest language to make the patient less anxious and more co-operative.
2. Place the limb to be tested in a relaxed and comfortable position both for the patient and for the examiner.
3. The stimulating and recording electrodes should be used as per the guidelines.
4. Measure the skin temperature to avoid errors. Motor and sensory nerve conduction velocities decrease at the rate of 1.3 to 2.4 m/sec per degree drop in skin temperature. During the nerve conduction studies the skin temperature is kept at 31 to 34 degree Celsius whenever possible or else the correction should be introduced.
5. The electrode impedance should be kept at minimum to avoid unnecessary artifacts.
6. A ground electrode should be attached to the lead being tested and is ideally placed between the stimulating and the recording electrodes
7. Pediatric stimulating and recording electrodes are used in infants.
8. Motor nerve conduction studies are performed prior to sensory conduction study to locate nerves.
9. The patient should be warned before giving each stimulation.
10. The pain should be reduced as much as possible by adjusting the intensity and duration of the stimulus, but still within the supramaximal range

## **Factors influencing nerve conduction parameters**

### **Temperature**

The temperature affects the conduction velocity (CV), both locally at the recording site and generally along the nerve.

Locally the amplitude increases as the temperature in the recording site decreases. The amplitude increases by 1.7% per degree Celsius.

The temperature also affects the conduction along the nerve segment. The CV decreases as it cools with a factor ranging from 1.2 to 2.4 m/s per degree Celsius. This varies for different nerve. This will reduce the amplitude. These two effects of the temperature on the amplitude neutralize each other. In order to standardize CV and amplitude measurements, it is recommended to keep the skin temperature at above 29° C for the dorsum of the hand and 27° C for the dorsum of the foot.

### **Age**

Conduction velocity is age dependent. Full term infants have conduction velocities, which are approximately half of that seen in adults. Conduction velocities rapidly increase from the values recorded in infants to near adult values at around 3-5 years of age. Furthermore pre-term infants have slower values at around 14-28 m/s. In the teens conduction velocities are almost the same as those of adult values. After the second to fourth decade, conduction velocities start to decrease very slowly. cv decrease by 0.5-1.8 m/s for each decade

### **Length of segment and height**

Longer nerves generally conduct more slowly than shorter nerves [5]. It has been shown that there is a good correlation between CV and estimated axonal length in the peroneal and sural nerves, but not in the motor or sensory fibers of the median nerve. Based on a good correlation between the height of the patient and the length of the nerve, the CV in lower limbs decreases by 2-3 m/s for 10 cm increase in height. Nerve impulses propagate faster in the proximal than in the distal nerve segments.

## **Gender**

It has been reported that CV is slower in women than that in men, but the correlation is complex since gender and height are not independent of each other. In our routine, we use the same reference values for women and men.

## **Reference values**

With standardized methods, the technique is sufficiently reproducible to allow the transfer of reference values from one laboratory to the other. A number of techniques and related reference values are given in the literature.

## **Pathophysiology**

The principle changes in nerve function are related to demyelination, axonal degeneration and conduction block. There are no absolute dividing lines between these situations; they show some overlap and also dynamic changes from one stage to another due to the interaction between Schwann cells and the axonal condition. In cases of demyelination, the conduction velocity is reduced. In cases of axonal degeneration, there may be normal velocity in the remaining axons, but a weaker muscle response is evoked. In cases of conduction block, no axonal degeneration occurs and therefore a normal response is obtained when stimulating distal to the lesion. When stimulation is performed proximal to the site of abnormality, a reduced number of axon conducts impulses, and a smaller than normal muscle response is obtained.

## **PROCEDURES**

### **I- MOTOR CONDUCTION STUDIES**

#### **Recording electrode**

For motor conduction studies (MCS), recording is formed over the belly of the muscle using a surface electrode. The active recording electrode is placed over the endplate zone of the muscle in order to record muscle activity at the moment of depolarization after the nerve impulse has arrived at the endplate. The muscle response, obtained after nerve stimulation is called the compound muscle action potential, CMAP, should have an abrupt negative take-off. If the electrode is away from the endplate, it will show an initial positive phase corresponding to the approaching electrical field of the impulses in the individual muscle fibers. The start of the positive phase corresponds to the start of the depolarization. However, because of the gradual increase in amplitude from the baseline it may be difficult to determine the exact start. If later part of the CMAP is used for latency measurements, the latency value will be contaminated with some conduction time along muscle fibers and not express only the nerve conduction time. However, when comparing distal and proximal latencies for CV calculations, other points than the take-off can be used, as long as the same parts of the CMAPs are used. It should be mentioned that in some situations, particularly in recording from the abductor digiti minimi (ADM) muscle of the foot in the study of the tibial nerve, underlying muscles with different positions of the endplate zones would contribute to the recording and give rise to positive components. If possible, measurements should be made to the point where the signal leaves the baseline

#### **Reference electrode**

The reference electrode should be placed in such a way that no recordings are taken from the muscle under study. If the reference electrodes are too close to the muscle, e.g. in its tendon, it will contribute with a significant amount of activity. Therefore, more distal positions are preferred, e.g. over the distal interphalangeal joint (from the thumb for the median nerve, dig V for the ulnar nerve, toe one for the tibial nerve and toe V for the peroneal nerve).

#### **Stimulation**

Usually stimulation is performed at two or more sites along the nerve. It is not adequate to stimulate at only one point and calculate the conduction velocity from the obtained latency between the stimulus and motor response and the distance. This is because the conduction time includes the slower in the conduction in the last segment of the nerve, time in the neuromuscular junction, and possibly some conduction along muscle fibers.

Therefore, two stimulation sites well separated from each other along the nerve are used.

In situations of local nerve lesion, short segments should be tested in order to localize the site of the abnormality. This technique has been called "inching" using small distance between stimulation points. We often use a distance of 10mm ("centimetry"). The recording site is kept constant, and the stimulation is performed every 10 mm across the area of suspected lesion. The analysis should focus on sudden jumps with prolonged latency values with more proximal stimulation or abrupt drop in amplitude.

Sometimes somewhat longer segments of the nerve are studied as part of the routine. In ulnar nerve studies, stimulation is often made at the wrist, and above and below the elbow. In studies of the peroneal nerve, stimulation is made at the ankle, and below and above the fibula head. In cases of difference in conduction along the two segments, centimetry is performed.

Generally surface electrodes (felt pad or steel) are used in motor nerve conduction studies. They are fixed on to a plastic bar a fixed distance apart. In a few situations it is preferable to use needle electrodes. A pair of monopolar needle electrodes is used these cases. Alternatively a surface electrode is used as an anode.

It is necessary to use needle electrodes when stimulating a nerve that is located very deeply. Therefore the muscle response can be obtained with less stimulus strength than the one necessary in surface electrodes. In short segment study the use of needle electrode provides more certain localization than that of surface electrodes.

The output impulse used for MCS is a rectangular wave with a duration of 0.1 or 0.2 ms. Sometimes it may be necessary to increase the stimulus duration to 0.5 or 1 ms in order to get maximal amplitude. In order to ascertain reliable maximal amplitude of the CMAP, it is advisable to increase the stimulus strength by 10-25% of that which is necessary to obtain maximal amplitude. In some situations a biphasic stimulus pulse is used in order to suppress stimulus artifacts.

## Parameters

A number of parameters are of interest in the assessment of different aspects of motor nerve functions.

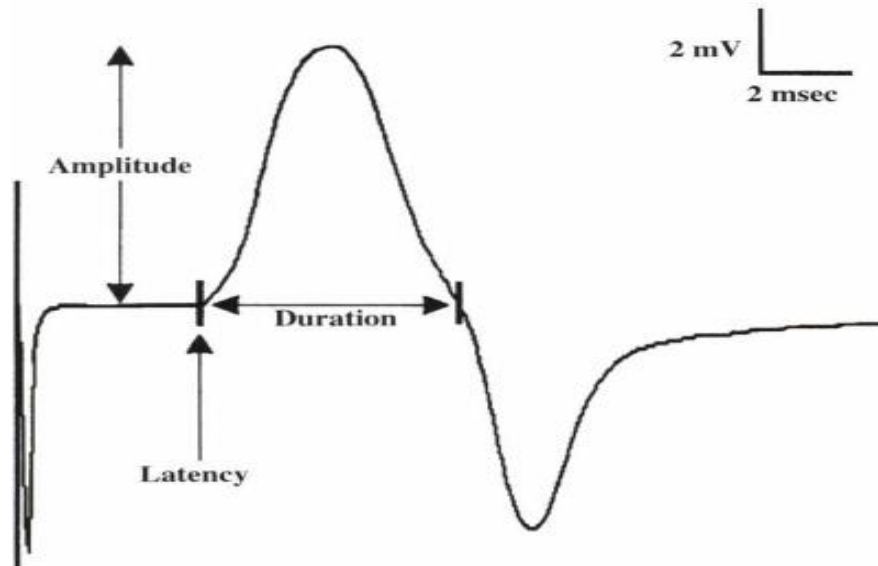

## Measured parameters of the CMAP

### Measured parameters

#### Latency (distal and proximal)

The latency is the time between the stimulus and the response. In motor nerve studies, this latency includes the nerve conduction time and also the neuromuscular transmission time. Distal latency is measured from the distal stimulation point to the first deflection from the baseline. Proximal latency starts at the proximal stimulation point and ends at the first deflection from the baseline.

#### Amplitude

The amplitude (AMPL) of the evoked motor response carries important information. It is dependent on the number of axons that conduct impulses from the stimulus point to the muscle, the number of functioning motor endplates and the muscle volume. The amplitude is measured from the baseline to the negative peak or from peak to peak.

## **Area**

The area represents a combination of the amplitude and the duration. It therefore reflects the number and synchrony of the muscle fibers activated. A prolongation of the duration can cause a decrease in the amplitude and may be misinterpreted as a conduction block. In this situation there may not be significant difference in the area. Area is the integrated area between the CMAP and the baseline.

## **Duration**

The duration (OUR) reflects the synchrony of individual muscle fiber discharges. If there is a significant difference in the conduction velocity among nerve fibers, the duration will be prolonged. This is mainly related to the range of the conduction velocities of the large myelinated fibers. Duration is measured from the onset to the first negative to positive baseline crossing.

## **Conduction velocity**

The conduction velocity (CV) is calculated by dividing the length of the nerve segment between the two stimulation points by the difference between the proximal and distal latency. In this way the slow distal conduction and any delay in the neuromuscular transmission is eliminated. It is calculated as follows.

$$\text{CV (m/s)} = \text{distance (mm)} / (\text{Lat.prox} - \text{Lat.distal})$$

When motor conduction velocity is calculated in this way it reflects the fastest motor axons.

## **Temporal dispersion**

Since nerve fibers have different conduction velocities, a more proximal stimulation site will give an increased duration of M wave. The change in duration with a proximal stimulation site is called temporal dispersion and is calculated as follows:

$$\text{DISPERSION} = 100 \times (\text{Dur.prox} - \text{Dur.distal}) / \text{Dur.distal}$$

In healthy subjects, the maximum dispersion in the ulnar nerve is 10-15%. In long nerve segments the CV may be lower and the dispersion higher than that seen in short segments.

### Amplitude and Area Decay

With proximal stimulation, when the duration of the M wave gets longer due to the temporal dispersion, the amplitude and the area of the M wave changes Decay is calculated as shown in these formulas.

$$\text{Ampl.Decay} = 100 \times (\text{Amp distal} - \text{Amp proximal}) / \text{Ampl distal}$$

$$\text{Area.Decay} = 100 \times (\text{Area distal} - \text{Area proximal}) / \text{Area distal}$$

In healthy subjects, the mean value of the *Ampl.Decay* is 4.5-6.2% in the ulnar nerve [and 5.6-7.7% in the median nerve]. The *Ampl.Decay* is larger in the lower extremities than in the upper extremities. The peroneal nerve has a mean value of 11% and an upper limit of 29% in the *Ampl.Decay*. On the other hand the *Area.Decay* is smaller than the *Ampl.Decay* in peroneal nerves. F-waves

## II- F WAVES

When the motor nerve is stimulated, nerve action potentials propagate both in the distal direction to evoke a muscle response, and in the proximal direction as a non-physiological event. Occasionally, the motor neuron depolarization may evoke a recurrent response by stimulating the first node distal to the neuron. There is only a small chance that the timing of the depolarization/repolarization allows this to happen. Normally a recurrent response is evoked in 0.5-5% of the stimulations with some differences between nerves.

### i) F wave from peroneal nerve

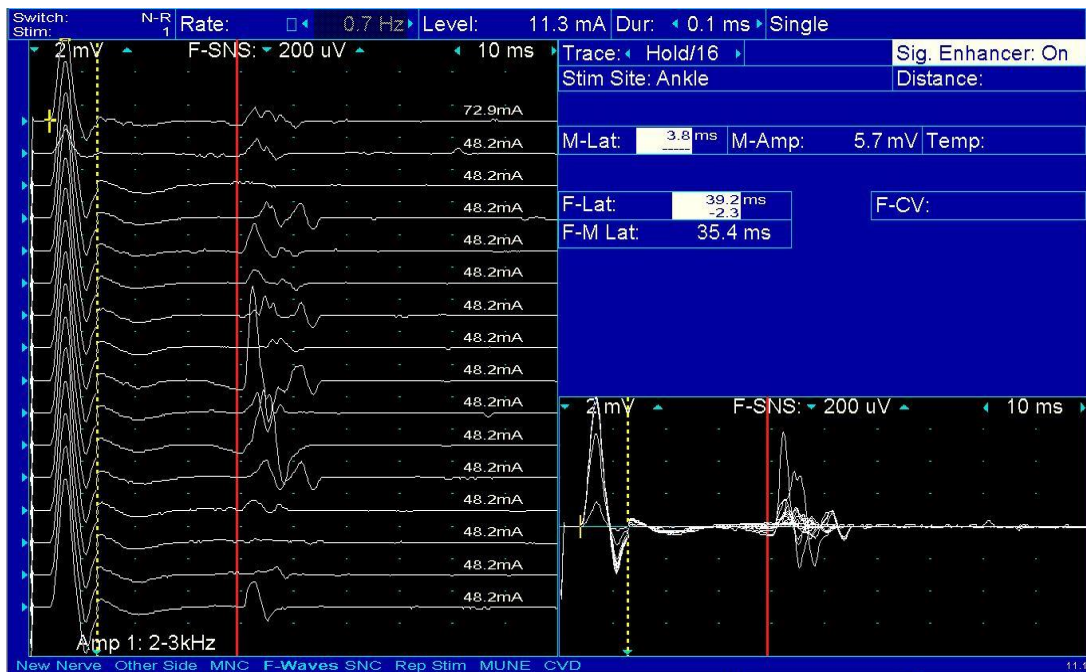

ii) F waves from tibial nerve

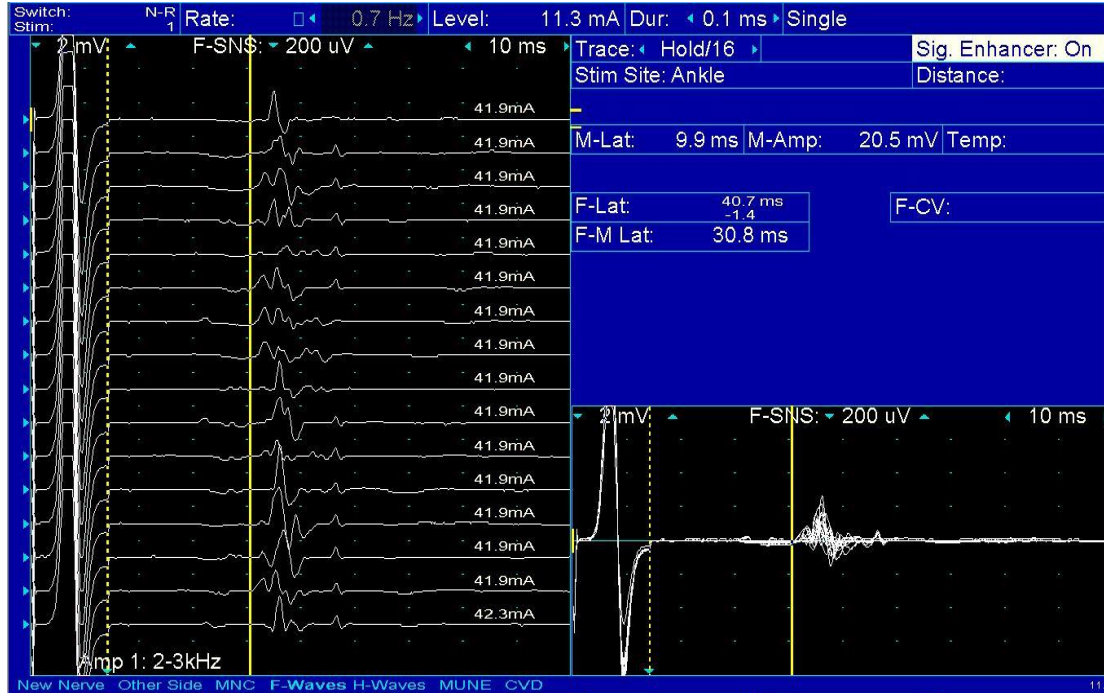

Studies of F-waves in normal peroneal (i) and tibial nerves (ii). Note the different occurrence of frequency of the F-waves in these two nerves.

The F-waves travel from the stimulation point on the nerve to the neuron and back to the muscle. By subtracting the distal latency, the time taken from the stimulus point to the neuron and back again to the stimulus point can be obtained. This time depends on the conduction distance involved. Instead of measuring the extremity length~ we relate the reference values to the height of the patient since arm and leg length are normally correlated to height.

Since each normal nerve contains hundreds of motor axons, it is usual to obtain 5-15 F-waves from 20 stimulations. They differ in latency and shape since they normally represent activity from different motor units. The frequency of occurrence is reduced when there is a conduction block anywhere along the nerve. F-wave measurements thus reflect conduction along the entire nerve and are therefore particularly useful in the study of general polyneuropathy and also when proximal segments are preferentially involved, as in Guillain-Barre syndrome (GBS).

## M-satellites (often called A-waves)

M-satellites are responses usually occurring between the CMAP and the F-wave they have a constant shape and latency and occur in at least 10 per 20 stimulations. In normal conditions they are only seen in the tibial nerve. They are present in various pathological conditions but are unspecific in relation to a given diagnosis. An M- satellite may be generated as an extra discharge in the stimulated axon (intermediate double discharges, IDD), be due to transmission-between two axons, axon reflex or represent the response from one axon with exceptionally slow conduction velocity. They are for example seen during the first days of GBS.

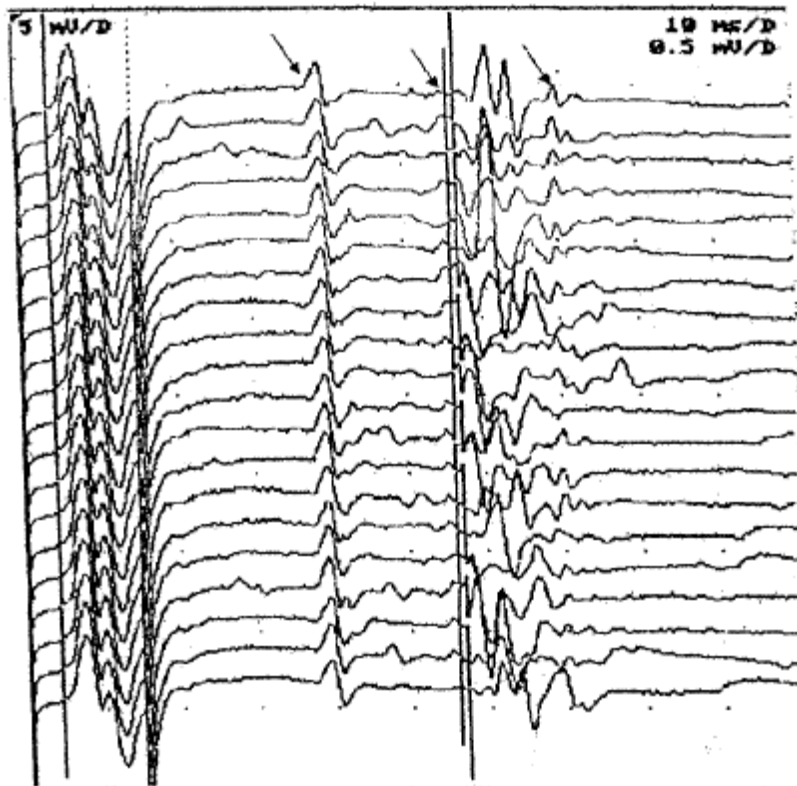

M-satellites (arrows) seen in the tibial nerve in a patient with normal conduction velocity. The two vertical lines indicate upper normal limit (right) and the estimated shortest F-latency among the obtained responses (left line). The F-wave latency is thus minimally increased. The number of F-waves is normal.



### III- H WAVE

An H-reflex is a monosynaptic reflex that can be elicited by the stimulation of muscle spindle afferents in the limbs. It is possible to evoke H reflexes on most nerves during the first year of life. In adults it can most easily be elicited in the calf muscles and flexor carpi radialis. The H reflex recorded from calf muscles - gastrocnemius, soleus - is mediated via the S1 root. The H reflex recorded from the flexor carpi radialis is mediated C1 root.

The H-reflex and F-wave differ in some aspects. The H-reflex contains a sensory and a motor branch. The H-reflex is studied only with a sub maximal stimulus and is abolished by supramaximal stimulation. Although consecutive F waves vary in latency and waveform, H reflexes remain constant in response to repetitive stimuli. This is because H reflexes occur from activating the same motor neuron pool. In contrast F- waves represent recurrent discharges from different groups of motor neurons with different conduction characteristics.

H-reflexes may be obtained more easily if a long stimulus duration is used i.e. 0.5 or 1 ms. The H reflex habituates and decreases in amplitude with stimulation rates > 0.5 Hz. The voluntary activation of the investigated muscle or Jendrassic's maneuver will enhance the H-reflex amplitude and shorten the latency.

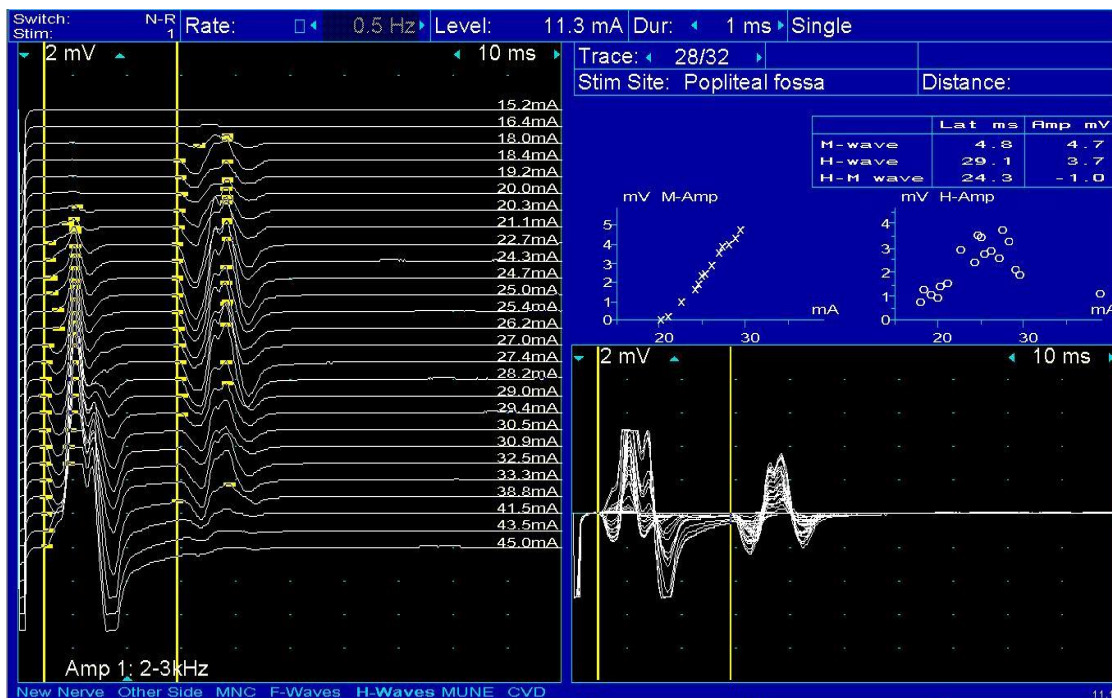

## Summary of parameters

The most common motor neurography parameters are summarized in Table

Parameter	Significance	Usually measured as	Analysis mode
<b><u>CMAP</u></b>			
Ampl	# axons, synchronisation	neg. amplitude (mV)	a/m
Area	# axons, "	neg. area (mV *ms)	A
Dur	neg. peak duration	(ms)	
Ampl decay	Cond. block dispersion	+ % reduction in ampl	a
Dispersion	axonal velocity disp	% increase in dur	A
CV	velocity of fastest axons	latency diff. (m/s)	a/m
Distal latency	velocity of fastest axons	latency	a/m
<b><u>F-waves</u></b>			
Latency	cond. of axons along entire nerve	Lat (min, mean in ms)	
Dispersion	axonal velocity dispersion	Min and max lat (ms)	a/m
# Of F-waves	# axons and MN excitability	# F-waves 20 stimuli	a/m
Amplitude	MUP shape + # F-waves	peak-peak ampl (● V)	a/m not often used
<b><u>M-satellites</u></b>			
Presence	Abnormal excitability or slowly conducting axons	present or not	M
<b><u>H-reflex</u></b>			
Latency	cond. along reflex arc	H-lat minus M-lat (ms)	a
Amplitude	excitability	M ampl / H ampl	a

Table 1. Note: CMAP = compound muscle action potential; CV= conduction velocity; MN = motor neuron.

## **Analysis**

All modern EMG systems have programs for neurography. Many have algorithms for automatic measurements. These algorithms vary and reference values may therefore differ somewhat between laboratories.

## **Motor conduction block**

One of the parameters in nerve conduction studies concerns the presence of impulse conduction blocks, CB. A Conduction block is the failure of an action potential to propagate throughout the length of a structurally intact axon. This may be seen at the site of a local nerve entrapment and is typical of autoimmune neuropathies (Guillain- Barre, GBS; chronic inflammatory demyelinating polyneuropathy, CIDP) and in multifocal motor neuropathy with persistent conduction block, MMN. In the hereditary demyelinating polyneuropathies, conduction block is seen only to a slight degree. Other polyneuropathies do not usually show conduction block.

The principal finding is the blocking of an impulse across a local segment without axonal damage. Therefore, stimulation distal to the block gives a normal CMAP whereas a proximal stimulation produces decreased amplitude.

This is normally studied in two ways in the motor nerve; by comparing CMAP at distal and proximal stimulation and by the assessment of the F-wave frequency.

In NCS, there is normally a slightly lower amplitude for proximal stimulation compared with distal and also a slight temporal dispersion. This can be explained simply as the difference in the conduction velocity between individual axons. This gives rise to an incomplete summation of signals and even some degree of so called phase cancellation. The longer the distance, the more pronounced these changes are. These effects are more pronounced in cases of slow conduction velocity due to demyelination, particularly when there is an increased spectrum of velocities among the axons. This means that when a reduction of the CMAP is obtained at proximal stimulation compared to distal response, the differential diagnostic problem is demyelination with general slowing causing abnormal temporal dispersion vs. a pure conduction block. In the first case, the distal-proximal amplitude drop is parallel to the temporal dispersion as expressed by the change in CMAP duration. With pure CB, there is no increase in temporal dispersion.

There have been several attempts to define criteria for conduction block. To discriminate between "pure" demyelination and a conduction block, the following criteria have been suggested (Ad Hoc Subcommittee of the American Academy of Neurology AIDS Task Force 1991)

**Conduction block is present if there is**

>20% *Ampl.Decay* or *Area.Decay* and <5% *Dispersion* or if there is  
>50% *Ampl.Decay* or *Area.Decay*, independent of *Dispersion*.

It has been demonstrated that both these criteria are equally sensitive in detecting a block.

Our own (SCTIMST) modifications of these rules are:

>25% (arm) or >40% (leg) *Ampl.Decay* and <15% *Dispersion* or if there is  
>50% *Ampl.Decay*, independent of *Dispersion* (in this case there is a combination of CB  
and demyelination)

The other parameter, which indicates Conduction Block, is the frequency of occurrence of F- waves. In cases of proximal Conduction Block, there may be no drop in amplitude in the distal part of the nerve, e.g:- in early GBS. In this case, the Conduction Block can be seen by a reduction in the occurrence of F-waves. The normal frequency of F-waves varies for different motor nerves. When 20 stimuli are given in a normal situation the different nerves normally show the following numbers of F-waves: ulnar 18, median 15, peroneal 10, and tibial 18. As can be seen, it is impossible to detect a slight reduction in the number of F-waves in the ulnar and peroneal nerve. Lack of response usually taken as an abnormal finding. In the tibial nerve, a better assessment of pathology can be made. It should be noted that in the interpretation of the number of F-waves, the CMAP amplitude needs to be considered. If the CMAP is reduced to half due to axonal degeneration, then the expected number of F-waves is correspondingly reduced.

The number of F-responses should also always be reduced when conventional MCS has shown a conduction block; otherwise a technical error is to suspect in the measurements.

## Anatomical variants

In normal subjects, there could be some anatomical variations in the muscle innervation. Martin-Gruber anastomosis is the most common anomalous innervation of the hand with an incidence of 15-28% [17]. The fibers innervating intrinsic muscles of the hand cross from the median nerve to the ulnar nerve. Sensory fibers are not involved. Martin-Gruber anastomosis can be divided into three types according to the muscle innervated by the crossing fibers. The most common type is type II, in which the crossing fibers innervate the first dorsal interosseus muscle. When the anastomotic fibers end in the ADM and abductor pollicis brevis the MG is classified as type I and type III respectively. Type III is the least common. Stimulating the median and ulnar nerves and recording from the muscles mentioned above can reveal Martin-Gruber anastomosis. The amplitude of the CMAP wave evoked by the median nerve stimulation at the elbow is found higher than the one evoked by stimulation at wrist level when recording is performed by a muscle with anomalous innervation. The CMAP obtained at the proximal site also has an initial small positive deflection because of the volume of conduction from the deep ulnar innervated muscles. In type I the amplitude of the M wave from the ulnar nerve stimulation shows a reverse discrepancy; lower with elbow stimulation and higher with wrist stimulation.

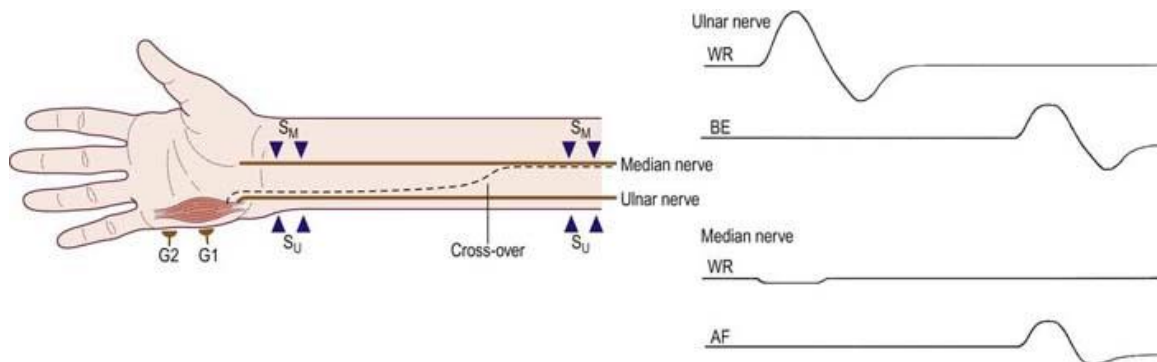

Median nerve MCS in a case of Martin-Gruber anastomosis. Note the higher amplitude and the initial positive going phase at stimulation at elbow.

When this anastomosis accompanies the carpal tunnel syndrome (CTS), an abnormally fast conduction velocity value, in the forearm segment of the median nerve is found, due to delayed distal latencies but a "normal" proximal latencies. Another common anatomical variation is the innervation of the extensor digitorum brevis by the accessory peroneal nerve. The deep peroneal nerve normally supplies this muscle. In 23 to 28 percent of population, the superficial branch, behind the lateral malleolus, innervates it. When a low CMAP is obtained distally, stimulation should always be performed behind the malleolus."

**Schematic summary of the relationship between CV and amplitude parameters in axonal (low amplitude) and demyelinating (low CV) neuropathy. Table 2..**

**Table 2.**

	Demyelination	Axonal degeneration	Conduction block
CV and dist latency		n/	N
Amplitude	n/•	•••	•
Amplitude decay	n/	N	
Dispersion		N	
F-wave latency		n/	N
# Of F-waves	n/•	•	•

*Table 2. Note: Classical findings in neurography at different types of pathology. = increased; ^ = decreased; n= normal*

## **IV- SENSORY CONDUCTION STUDIES**

The pathophysiological principles regarding sensory nerves are the same as those discussed for motor nerves. Sensory neurography differs in some aspects: The amplitudes are much smaller than those in MCS and since the recordings, are carried out on the nerve itself. Furthermore, only one stimulation site is necessary for calculating CV. The stimulation recording can be performed in both the orthodromic or antidromic direction. Some of these things will now be discussed.

### **Recording electrode**

The recording may be performed orthodromically or antidromically. The conduction velocity is the same but other parameters are different. In some instances one choice is preferred, but in, other cases the choice is based on tradition. Table 3 shows differences between orthodromic and antidromic methods.

**Table 3. Differences between orthodromic and antidromic nerve stimulation**

<b>Orthodromic</b>	<b>Antidromic.</b>
<b>No muscle artifact (+)</b>	<b>Less painful (+)</b>
<b>More painful</b>	<b>Larger amplitude (+)</b>
<b>Lower amplitude</b>	<b>Muscle artifact in mixed nerves</b>

Usually surface electrodes are used for recording purpose. The electrodes may be so called ring electrodes, e.g. around the digits. More commonly we use felt pad electrodes with a fixed inter electrode distance between the two recording poles. The electrode is placed along the nerve with the "active" towards the point of stimulation.

If the electrode is placed along the nerve, the two poles record an identical signal, often biphasic in shape with an initial smaller positivity and a larger positive part. In the amplifier the two signals are subtracted, giving rise to a triphasic configuration. The shape, in particular the duration and amplitude of the recorded signal is dependent on the conduction time between the two poles (distance and CV). This means that, the inter electrode distance has to be kept constant within the laboratory.

### **Reference data must be collected using the same technique that is used in routine studies**

In cases when near nerve needle electrodes are used, all the parameters except CV are different. In this case a special needle electrode is inserted just outside the nerve (the position may sometimes be tested by using the electrode for stimulation. An optimal position is found when a muscle response is obtained with minimal current, often less than 2mA). The recording may show multiple peaks indicating the difference in conduction velocity among individual axons. This is particularly apparent in cases of pathology. Amplitude parameters are dependent on both the needle position in relation to the nerve, and the distance between the stimulation and recording. It is often not very reproducible in pathology. We use needle electrodes in Morton's metatarsalgia and meralgia paresthetica.

### **Stimulation**

Stimulation can be performed with a surface electrode, or with a needle electrode. In the first and more common case, the electrode is placed over a sensory nerve, or sometimes over the relevant skin area. The stimulus duration is often 0.1 ms and the frequency around 1 Hz. The stimulus strength is increased, as long the recorded response is increases. With higher stimulus strength, the increase in pain and, depending on the stimulus site, the motor artifacts may significantly disturb the recordings. Here an optimum must be found. When a needle electrode is used, similar considerations should be made. In our study we used needle electrodes to obtain high selectivity, e.g. in the stimulation of individual digital nerves in cases of Morton's metatarsalgia.

## Parameters

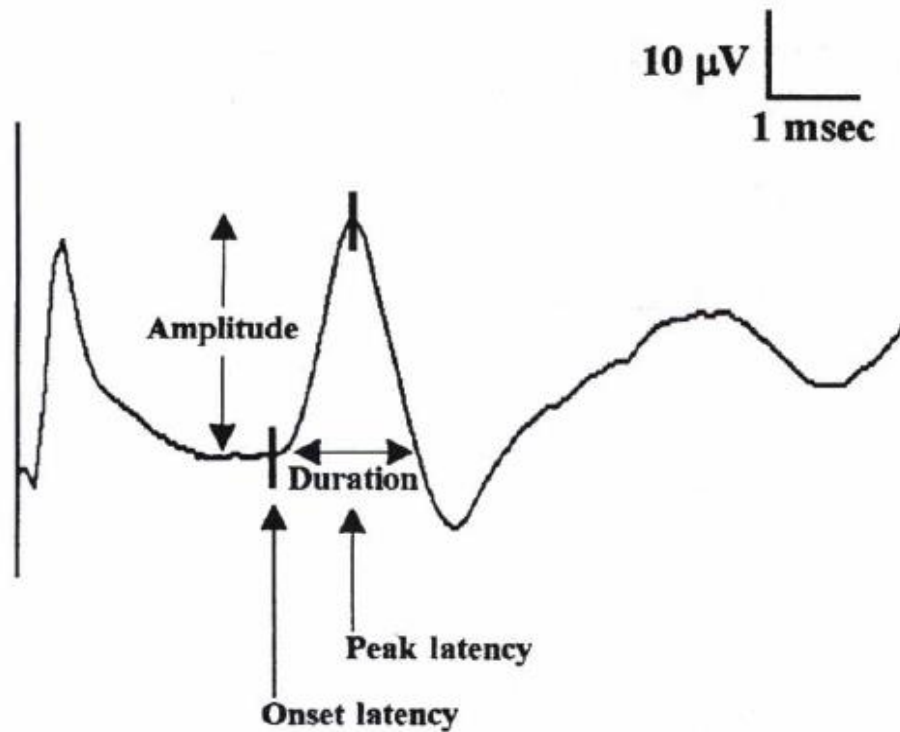

## Latency (distal and proximal)

The latency is the time from the stimulus to the first positive peak of sensory nerve action potential (SNAP). If there is no clear positive peak in antidromic recording, the latency is measured from the take-off from baseline. For the normal latency of a nerve there should be approximately two hundred nerve fibers conducting normally and having 10 m V or more of diameter.

Some laboratories have a tradition of measuring latency to the first negative peak. Since negative peak latency includes the rise time of SNAP and indicates the temporal dispersion, it is not recommended to use negative peak latency to calculate the conduction velocities.

### **Amplitude**

The amplitude of the SNAP should be measured from the first positive peak to the highest negative peak. Some authors measure the amplitude as the maximum peak-to-peak amplitude or as the amplitude between a line joining the positive peaks as the positive value and the negative peak. The amplitude reflects the number of nerve fibers having a diameter of 9 μm or more.

### **Area**

The area is the integrated area between the signal and baseline over the DUR. The area represents the combination of amplitude and duration; therefore this reflects the number and synchrony of the activated nerve fibers.

### **Duration**

The duration is measured from the first positive peak to the last positive peak. When there is no presence of the initial positive peak, the duration is measured from take-off on the baseline.

### **Conduction velocity**

The conduction velocity (CV) is calculated by dividing the length of the nerve segment from the stimulus point to the recording point by the positive peak latency. It should be calculated as follows.

$$\text{CV (m/s)} = \text{distance (mm)} / \text{Latency}$$

When the sensory conduction velocity is calculated in this way, it reflects the conduction velocity of the fastest sensory fibers.

### **Temporal dispersion and decay**

Since physiologic temporal dispersion affects the sensory action potential more than the muscle response, these parameters are not easily used in the routine studies. This is due to the difference in duration of individual unit discharges between nerve and muscle. With short-duration diphasic sensory spikes, a slight latency difference could line up the positive peaks of the fast fibers with the negative peaks of the slow fibers, cancelling both.

**Table 4.**

Parameter	Significance	Usually measured as	Analysis mode	Comment
Latency	conduction velocity	positive peak (ms)	a/m	
CV	conduction velocity	distance/latency (m/s)	a/m	
Amplitude	# axons, temporal disp	peak-peak ( $\bullet$ V)	a/m	
Area	# axons, temporal disp	total area ( $\bullet$ V * ms)	A	
Duration	dispersion	pos.-pos. peak dur (ms)	a/m	
Late components	conduction dispersion	shape	M	in needle rec.

*Table 4 showing parameters usually measured in sensory neurography. Note: for explanation, see Table 1.*

### Analysis

Modern EMG equipment has programs to measure these parameters. Often averaging is necessary in order to obtain a good signal to noise ratio.

## **V- AUTONOMIC NERVE TESTING**

It should note that this is important in the general neurophysiological investigation of a patient with neuropathy. Some of the most commonly used methods are indicated in table given below

### **Autonomic tests**

Autonomic testing includes Heart rate variation

(At deep breathing, Valsalva, tilt test)	parasympathetic (sympathetic)
SSR	Sympathetic
Pletysmography	Sympathetic

### **Sympathetic Skin Response**

The sympathetic skin response is the electro-dermal activity caused by alteration in the electrical skin resistance from minute changes in the pseudo-motor activity and serves as an indirect assessment of the autonomic nervous system. A variety of sensory stimuli (auditory, tactile and deep inspiration) can elicit an SSR.

### **Procedure**

The active recording electrode is placed over palm on the hand or the plantar surface of the foot and the corresponding reference electrode is commonly placed over the dorsum of the hand or foot. Electrical stimuli 0.1 to 0.2 ms duration and 10 -20mA in intensity can be applied to the wrist or ankle on either side to depolarize the sensory nerves. Random frequency of stimulation is preferable to avoid the habituation of the response. Filter setting 0.5 Hz to 2 KHz is optimum for the recording.

The recoded response may have one to three phases. The latency is not useful in clinical practice. The sympathetic skin response is normal when it is present and abnormal when absent, The absent SSR in patients with neuropathies correlates with involvement of unmyelinated autonomic fibers.

SSR has two types of responses according to the polarity of the waveform with the maximum amplitude

P type & N type

P type- maximum positive deflection

N type-maximum negative deflection

P type is more frequent in healthy subjects

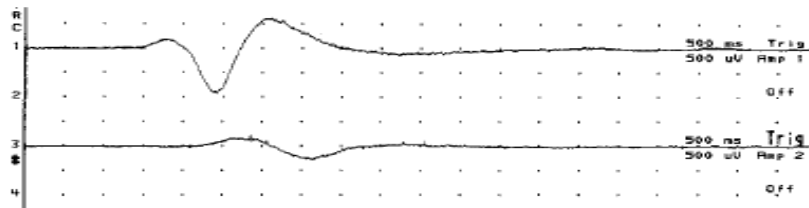

Fig. 1. Sympathetic skin response recorded from upper (1) and lower (3) extremities.

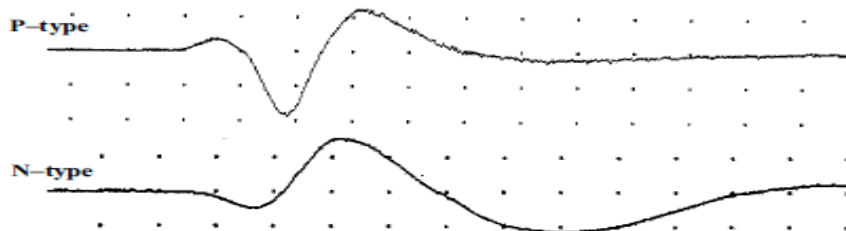
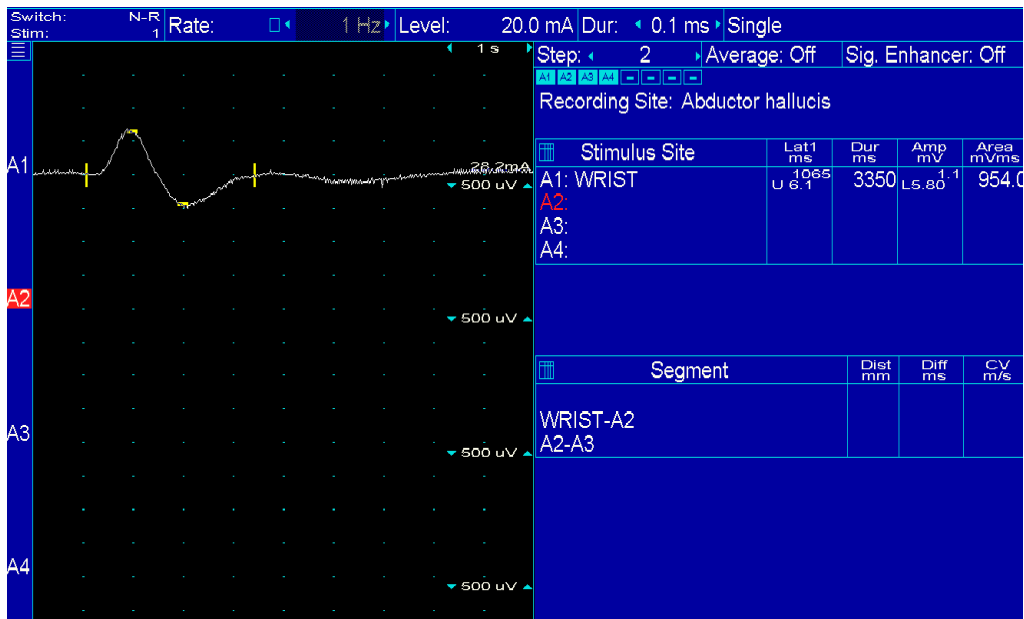

Fig. 2. P-type and N-type waveform of sympathetic skin response.



## **VI - REPETITIVE NERVE STIMULATION**

Repetitive nerve stimulation (RNS) is used in the evaluation of patients with suspected neuromuscular transmission disorders (NMTD) such as myasthenia gravis (MG) or Lambert-Eaton myasthenic syndrome (LEMS). RNS is a modified motor NCS where instead of recording CMAPs with single supramaximal electrical stimuli, a train of 8-10 stimuli is applied and the sequential response of amplitudes and/or areas measured. This may be carried out at low (3-4Hz) or high frequency stimulation (20-50 Hz). In the later case the train is prolonged to allow 2-10 seconds of continuous data to be measured. Both distal and proximal muscles/nerves should be studied in every patient suspected of an NMTD as the sensitivity of the test is greatly increased by this means.

With low frequency stimulation in normal subjects, the CMAP amplitude and/or area falls over the first 4-5 stimuli by a maximum of 10-12%. The maximum fall should be between the potentials 1 and 2. A number of departments with specific studies have published studies on RNS over time both before and after a period of maximum voluntary contraction of the muscle to pick up early or late NMT failure. High frequency stimulation may be used to discover evidence of a post-synaptic transmitter release disorder like LEMS. It is painful and requires considerable patient tolerance. There is evidence that recording low frequency RNS immediately before and after a 20- 30 second period of maximum voluntary contraction by the patient is equally sensitive and is more humane.

There are many pitfalls in the RNS test and artifact almost always gives rise to an abnormal test. Thus adherence to a strict protocol and heightened suspicion on the part of the CN to an abnormal result is essential as are repeated studies for reproducibility of abnormalities.

## Physiological basis for the RNS

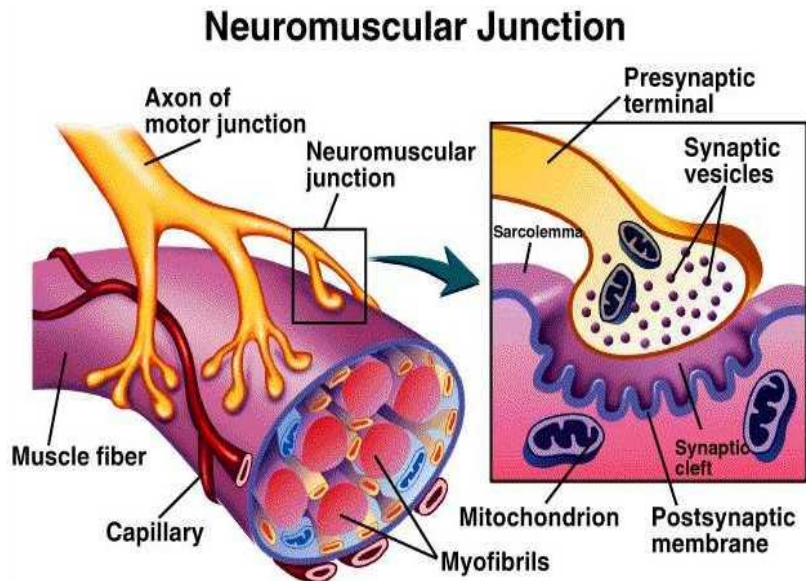

The neuromuscular junction consists of the motor axon terminal, the synaptic cleft, and the post-synaptic muscle membrane. As the motor axon potential depolarizes the nerve terminal, voltage gated calcium channels open increasing the concentration of calcium in the pre-synaptic nerve terminal. This in turn facilitates the release of quanta of acetylcholine (ACh) from the nerve terminal into the synaptic cleft. ACh binds to receptors on the post-synaptic membrane causing depolarisation (end plate potential). The size of the end plate potential is dependent on the amount of ACh released and its binding to receptors. In the healthy state, the end plate potential reaches a threshold level and causes an action potential to be propagated along a muscle fibre resulting in muscle contraction. Normally there is a large safety factor for neuromuscular transmission with the amount of ACh released per impulse several times that required to generate a threshold level end plate potential.

In low frequency RNS, the rate of stimulation is such that the end plate physiology is stressed, but not to the level that produces the natural facilitation of NMT at greater stimulation frequencies. Thus an abnormal fall (decrement) in CMAP amplitude and/or area at low stimulation rates indicates a drop in the safety factor for transmission whether from a pre- or post-synaptic cause.

In high frequency stimulation natural facilitation is enhanced by pre-synaptic Ca<sup>++</sup> influx and this may counteract a process such as LEMS where quantal release is depressed.

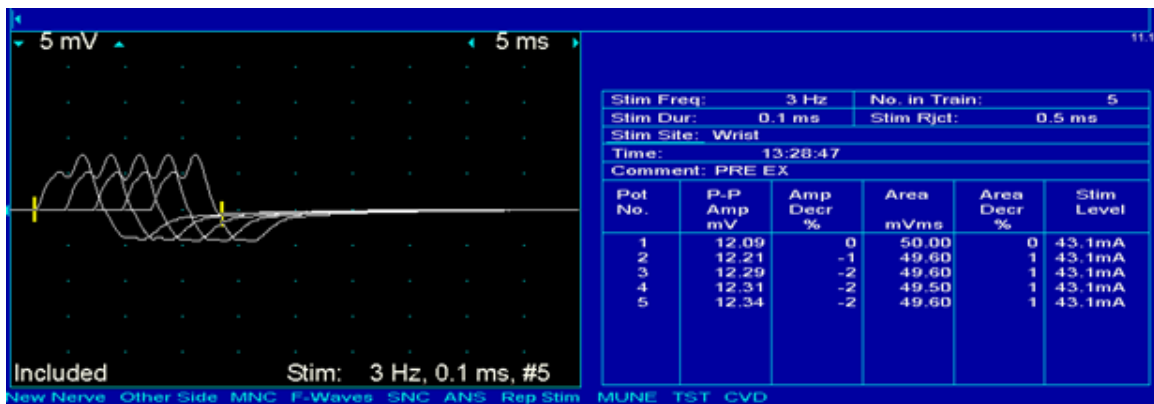

Normal response of a slow RNS from ADM with right ulnar nerve stimulation

## **VII - BLINK REFLEX**

The cranial nerves that can be readily tested are the trigeminal (V), facial (VII), and spinal accessory (XI).

### **Facial (VII)**

The facial nerve is examined by recording the latency and amplitude from a stimulus at only one site along the course of the nerve. Nerve conduction velocities are not calculated.

### **Stimulation site:**

Place the electrodes behind the angle of the jaw, with the cathode posterior to the earlobe and the anode behind. This placement stimulates the nerve just before it enters the parotid gland. Alternatively, you may place the cathode over the sternocleidomastoid and anode over mastoid.

### **Ground:**

Usually the ground is placed over the parotid area, but you may place it on the chin or forehead also.

### **Recording sites:**

Place the active recording over the orbicularis oculi of the both eyes. The facial nerve may be evaluated differently - by using the blink reflex, which will be discussed with the trigeminal nerve (below).

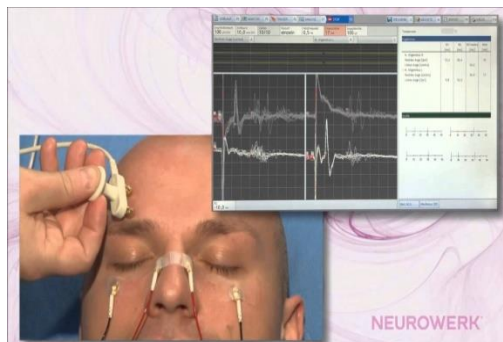

As the sensory fibers of the Vth nerve enter the brain stem, they establish three kinds of synaptic connections with the VIIth nerve nuclei: -One, a direct and monosynaptic with the ipsilateral VIIth nerve nucleus. - Another, indirect and polysynaptic with the contralateral VIIth nerve nucleus. - A third, also polysynaptic, again to the ipsilateral VIIth nerve nucleus.

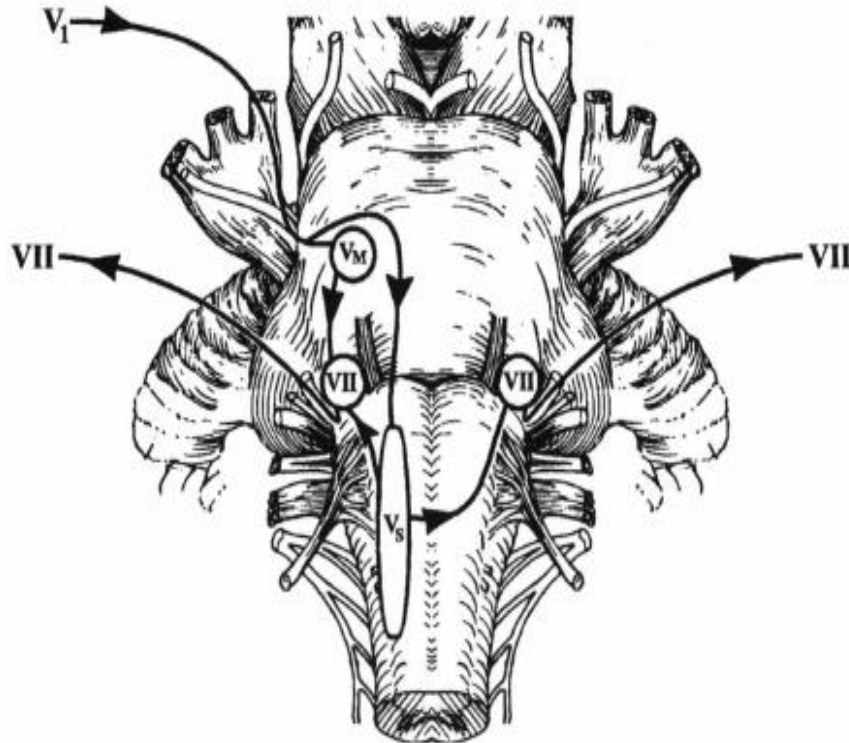

These connections are demonstrated clinically by the fact that when the glabella is lightly tapped with a reflex hammer or a finger, a brisk blinking reaction is seen bilaterally. The blink reflex is the electrical equivalent of this reaction referred to clinically as the glabellar reflex. Stimulation of the supraorbital branch of the Vth nerve as it enters the skull through the supraorbital foramen will result in contraction of the orbicularis oculi muscles bilaterally.

Using two channels on the cathode ray tube to study both sides simultaneously best performs the test. On each side an active electrode is placed over the orbicularis oculi muscle on the outer canthus of the eye and the reference on the lateral aspect of the nose. One ground is used and is placed over the chin.

The Vth nerve is stimulated via its supraorbital branch over the supraorbital foramen; the sweep speed used is 10 msec/division and the gain set at 200  $\mu$ V/division. On the ipsilateral channel, both direct and indirect responses are seen, the direct of a short latency and mono or biphasic configuration, the indirect of a long, usually variable, latency and polyphasic configuration. On the contralateral channel, only the indirect, long latency polyphasic response is seen.

These connections are demonstrated clinically by the fact that when the glabella is lightly tapped with a reflex hammer or a finger, a brisk blinking reaction is seen bilaterally. The blink reflex is the electrical equivalent of this reaction referred to clinically as the glabellar reflex. Stimulation of the supraorbital branch of the Vth nerve as it enters the skull through the supraorbital foramen will result in contraction of the orbicularis oculi muscles bilaterally.

Using two channels on the cathode ray tube to study both sides simultaneously best performs the test. One each side an active electrode is placed over the orbicularis oculi muscle on the outer canthus of the eye and the reference on the lateral aspect of the nose. One ground is used and is placed over the chin.

The Vth nerve is stimulated via its supraorbital branch over the supraorbital foramen; the sweep speed used is 10 msec/division and the gain set at 200  $\mu$ V/division. On the ipsilateral channel, both direct and indirect responses are seen, the direct of a short latency and mono or biphasic configuration, the indirect of a long, usually variable, latency and polyphasic configuration. On the contralateral channel, only the indirect, long latency polyphasic response is seen.

## Normal blink reflex

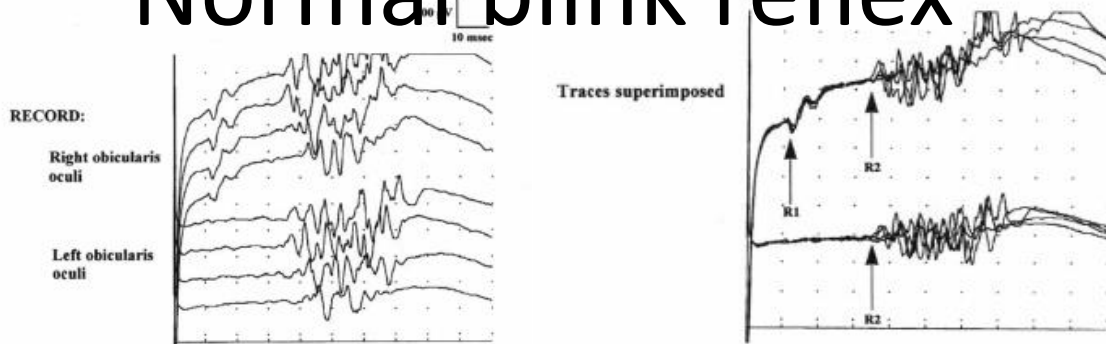

**Normal blink reflex.** Stimulating right side, recording both orbicularis oculi muscles in a normal subject. On the ipsilateral side, an early R1 potential is present at 11 ms and a late R2 potential at 34 ms. R1 usually is a biphasic or triphasic potential and stable from stimulation to stimulation. The R2 potential is variable and usually polyphasic. On the contralateral side, only a late R2 potential is seen at 35 ms. Superimposing several traces is useful to help determine the shortest R2 latencies.

## Normal Blink reflex

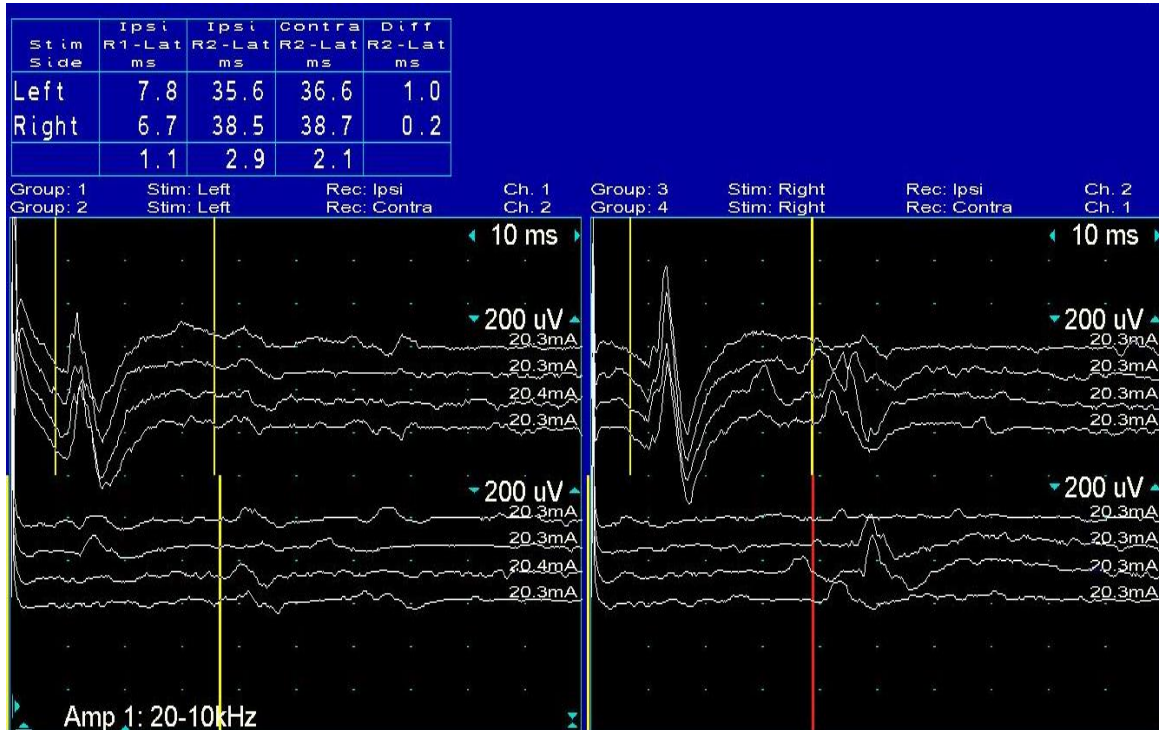

## Blink Reflex Findings

In unilateral Vth nerve lesions, all three responses are equally affected. In unilateral VIIth nerve lesions, stimulation on the same side of the lesion will result in delayed or absent direct and indirect responses ipsilaterally but a normal indirect response contralaterally. When the nerve is stimulated on the healthy side, both the direct and indirect responses are spared while the contralateral indirect response is affected.

The blink reflex can be used in the evaluation of toxic neuropathies and in comatose patients and multiple sclerosis as a means of evaluating brain stem functions.

# **ELECTROMYOGRAPHY**

## Volitional Activity in Muscle

Electromyography (EMG) is the science involved with the study of electrical activity in muscle. The basic physiologic unit of normal skeletal muscle function is the motor unit, which consists of a lower motor neuron (LMN) and a finite number of muscle cells (fibers). When a LMN discharges in response to volitional or reflexive activation, an action potential is propagated along its axon (nerve fiber) chemically recreated at end plates, and then propagated along muscle cell membranes just prior to muscle contraction.

## Motor Unit Potentials

The composite electrical activity in muscle cell membranes when a motor unit discharges is called a motor unit potential (MUP). The size of a single MUP depends upon the type and size of the motor unit and the proximity of the unit to the recording electrode. Primary muscle disease may cause MUP durations and amplitudes to decrease (due to loss of individual fibers).

Manipulating posture or using reflexes to induce movement can record motor unit potentials. In some neurogenic diseases, the duration and amplitudes of MUP increase due to increases in innervation ratios caused by collaterization and reinnervation. These unusually large MUP have been referred to as giant motor unit potentials. During periods of active degeneration, MUP may show slightly increased durations and amplitudes. The presence of polyphasic MUP may point to conduction impairment in smaller intramuscular nerve terminals.

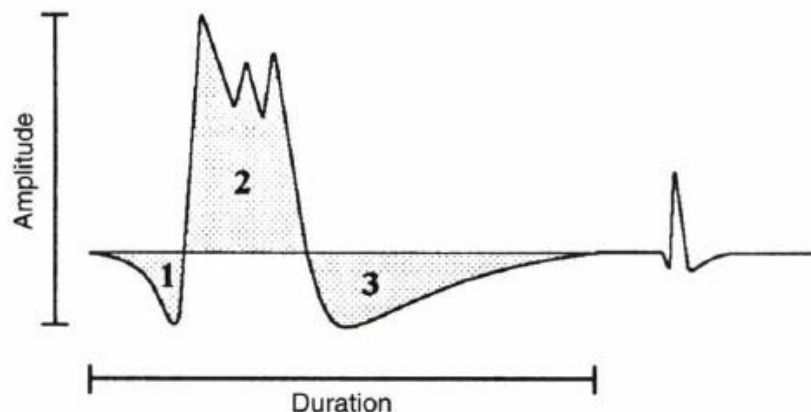

## **Interference Patterns**

Normal volitional muscle contraction is brought about by the repetitive asynchronous activation of large numbers of motor units. Recruitment is the process of adding motor units to ones that are already active thus increasing the force of contraction. Electromyographically, the pattern of muscle contraction during normal physiologic activity is called an interference pattern because the individual MUP are so numerous, they seem to "interfere" with each other in a recording depending upon the intensity of muscle contraction, and the interference pattern may be called complete or incomplete. The interference pattern can be recorded from single muscles with intramuscular monopolar needle electrodes or fine wire electrodes. Both type of electrodes are insulated except for the tip of the needle or wire. These procedures allow for an evaluation of a specific muscle with little to no interference from other muscles.

Fine wire electrodes, for example, have been used successfully in small animals to assess the function and synergistic action of the external urethral sphincter during cystometrography. In peripheral neuropathies, the interference pattern is markedly reduced or completely lost.

## **Evoked Activity in Muscle**

In clinical settings, skeletal muscle activity is usually evoked by electrical stimulation of motor nerves while intramuscular needle or surface electrodes are used as recording electrodes. In other evoked responses, receptors are physiologically stimulated and muscles are reflexively activated. Muscle activity may also be produced by electrical or electromagnetic stimulation of the motor cortex. Mechanical injury to muscles by needle recording electrodes will also evoke activity. Electrical or reflexive activation of muscles will be described in other briefs.

## **Insertion Potentials**

Other than end-plate noise, normal muscle membranes are electrically silent if there is no LMN activity. However, when a needle electrode is inserted into or moved in a normal healthy muscle, it is accompanied by electrical activity called insertion potentials. Insertion potentials are caused by the mechanical stimulation of muscle fibers and usually cease when needle movement ceases. As described below, insertion potentials may be prolonged in neuropathic, or myopathic disorders and mixed with other abnormal potentials such as positive sharp waves and fibrillation potentials. Insertion potentials may be reduced in severely atrophied muscle.

## **Spontaneous Activity in Muscle**

Spontaneous activity in muscle, when it occurs, may be initiated in the perikaryon of the LMN, its peripheral axon, the end plate, or the muscle membrane itself. As mentioned previously, if skeletal muscle is not volitionally or reflexively activated, it is electrically quiescent, therefore, most spontaneous activity in muscle is often associated with neuromuscular abnormalities

### **Miniature End-Plate Potentials**

Each skeletal muscle cell is innervated by a single branch of the LMN axon at a synapse referred to as the end plate. In the absence of LMN activation, spontaneous activity in muscle is only recorded in the motor point, an area in the muscle where there is a high concentration of end plates. This activity may be recorded by needle electrodes and referred to as end-plate noise, which consists of large numbers of miniature end-plate potentials (MEPP). A single MEPP is a non-propagated calcium-dependent potential caused by a small number of neurotransmitter packets being released spontaneously at the end plate. Motor end-plate noise as well as other muscle potentials described below can be recorded with intramuscular needle electrodes.

### **Fasciculation Potentials**

Fasciculation is a spontaneous twitch when motor unit or parts of neighboring motor units discharge. Electrically, fasciculation's have durations, amplitudes and other characteristics similar to MUP. Recent findings suggest that benign fasciculation's are caused by emphatically activated muscle fibers as a result of discharge in pacemaker fibers in either nerve or muscle. Although very little tension is produced, fasciculation can sometimes be observed through the skin. Fasciculation can be seen in a variety of diseases affecting nerve and muscle, and infrequently in degenerative diseases affecting the spinal gray matter.

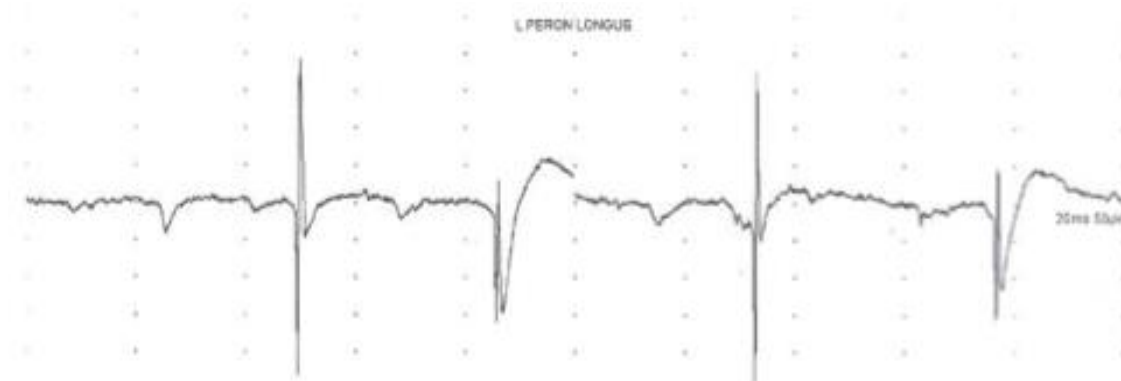

## **Fibrillation Potentials**

Fibrillation potentials (fibs) are brief spontaneous bi- or triphasic potentials that are seen in neurogenic and primary muscle disease. This potential, also called a denervation potential, is one of the electrical hallmarks of partially or completely denervated muscle and is produced by the discharge of a single muscle fiber. The amplitude of fibrillation potentials may range from 50-350  $\mu\text{V}$  with durations of 1-2 msec. Fibs appear in denervated muscle after a latent period that is proportional to the length of remaining axons distal to the site of a nerve lesion. Their onset may be preceded by periods of increased insertional activity. Once these potentials appear in denervated muscle, their rate of occurrence increases over a period of several weeks. They will persist until muscle is reinnervated, or until no viable muscle fibers remain. Fibrillation potentials are also seen in myopathic disorders such as muscular dystrophies, polymyositis, and dermatomyositis. Their origin is related to oscillating membrane changes or irregular potentials caused by membrane instability. In neuropathies, where the primary feature is demyelination, fibrillation potentials may not be found. The sound of these potentials from a loudspeaker has been likened to crackling cellophane.

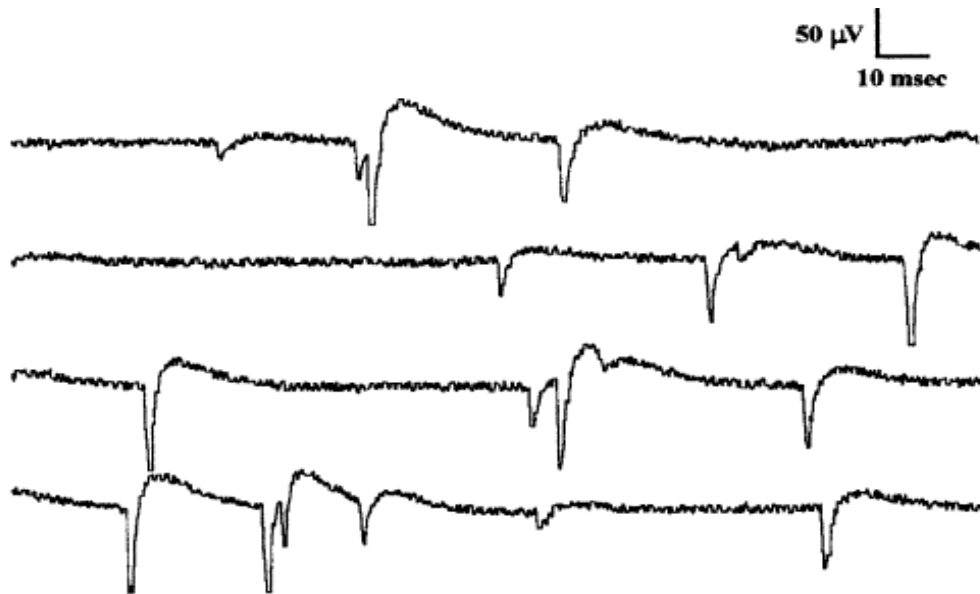

**FIGURE 14-9**

***Fibrillation potential.*** Spontaneous depolarization of a single muscle fiber. Note the initial positive deflection, brief duration, and triphasic morphology.

### Positive Sharp Waves

Positive sharp waves (PSW), like fibrillation potentials, occurs when muscle is denervated, but also occur in a variety of myopathic disorders. In denervation, PSW may precede fibrillation potentials by one or more days. The special feature of the PSW is the initial positive phase followed by a more gradual negative-going phase. By convention, EMG recorders are configured such that positive potentials produce a downward deflection in the recording. These potentials make a lower pitched sound than fibrillation potentials and usually have a lower discharge rate.



### Bizarre High Frequency Discharges

Bizarre high frequency (BHF) activity consists of polyphasic potentials that discharge spontaneously at a high frequency. Within the train of discharges, each potential may have precisely the same appearance. Such behavior suggests the presence of pacemaker muscle fibers that oscillate. The onset may be associated with needle movement and the discharges start and stop abruptly. These potentials can occur in a variety of myopathic conditions including hyper adreno-corticism, and polymyositis. Some have referred to these as pseudo-myotonic potentials because they do not wax and wane like true myotonic potentials. From the loudspeaker of the electromyograph, these discharges have continuous high-pitched motor-like sounds.

### Myotonic Discharges.

Myotonic potentials occur in muscles as a result of permeability abnormalities in muscle fiber membranes. Muscles continue to be electrically activated even after the cessation of volitional contraction. These high frequency (100 to 200/sec) potentials spontaneously wax and wane in amplitude and rate in an EMG pattern that has become the electrical signature of myotonia. In addition to normal presynaptic nerve activity, mechanical muscle movement, or needle displacement may precipitate the onset. Spontaneous activity may last for a second or more, which persist in the presence of depolarizing and non-depolarizing muscle relaxants. In some types of myotonia, the repetitive discharges may be explained by altered chloride conductance in muscle membranes while in other types, the malady may be related to a disorder in caption conductance. Audio-monitoring of myotonic potentials reveal the most characteristic EMG sounds, that of a dive-bomber. For this reason, myotonic potentials are referred to as "dive-bomber potentials."

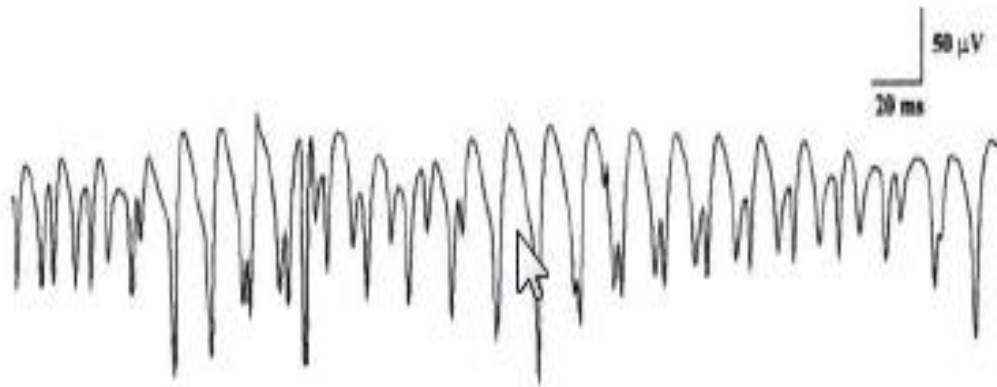

**FIGURE 14-19**

*Myotonic discharge (spontaneous discharge). Note the waxing and waning of both amplitude and frequency.*

## Single Fiber EMG

Single-fiber electromyography (SFEMG) is a selective EMG recording technique that allows identification of action potentials (APs) from individual muscle fibers. The single-fiber needle allows extracellular recording of individual muscle fiber action potentials during voluntary contraction termed single-fiber electromyography (SFEMG), this technique has contributed substantially to the understanding of muscle physiology and pathophysiology. SFEMG supplements conventional electromyography by determining (a) fiber density—the number of single-fiber action potentials within the recording radius of the electrode and (b) electromyographic jitter—the variability of the inter potential interval between two or more single muscle fibers belonging to the same motor unit.

### Principle of SFEMG

SFEMG is performed by inserting single fiber concentric needle into a muscle.



The electrode is positioned to record action potentials (APs) from 2 muscle fibers that are innervated by the same motor nerve fiber. The selectivity of the technique results from the small recording surface (25  $\mu\text{m}$  in diameter), exposed at a port on the side of the electrode, which is 3 mm from the tip.

- Filter settings should be set at 500 Hz for the high pass filter, and 10–20 kHz for the low pass filter
- The selectivity of the recording is further heightened by using a high pass filter of 500 Hz.
- APs from distant muscle fibres contain relatively more low-frequency components & filtered off.

## Single Fiber Needle Electrode

	<b>Single Fibre</b>	<b>Concentric</b>
Electrode diameter	25 $\mu\text{m}$	0.1 mm
Recording area	300 $\mu\text{m}^2$	1 mm <sup>2</sup>
Source	1-2 fibre	5-12 fibres
Potential shape	<i>Biphasic</i>	Bi / tri phasic
Amplitude (mV)	<i>1-10</i>	0.3 - 3
Duration (ms)	<i>&lt;1</i>	2-15
Rise time ( $\mu\text{s}$ )	<i>100-150</i>	100-500

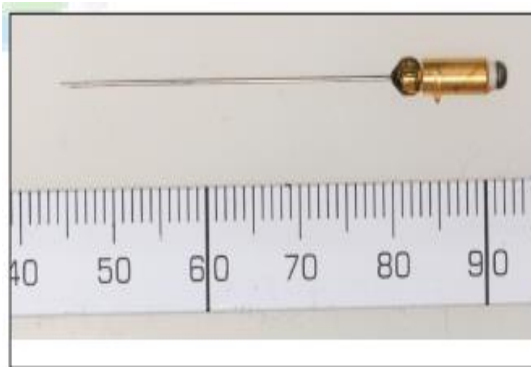

Figure 1: Single fibre needle electrode

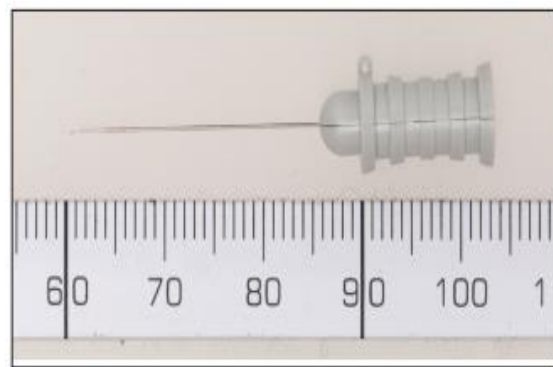
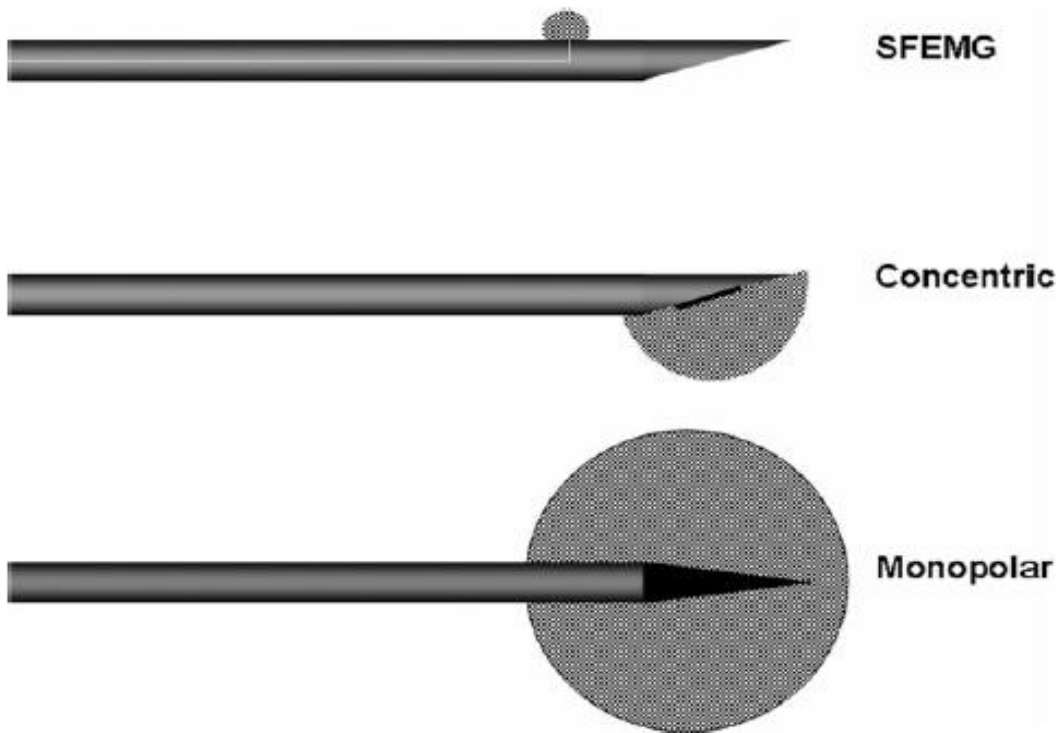
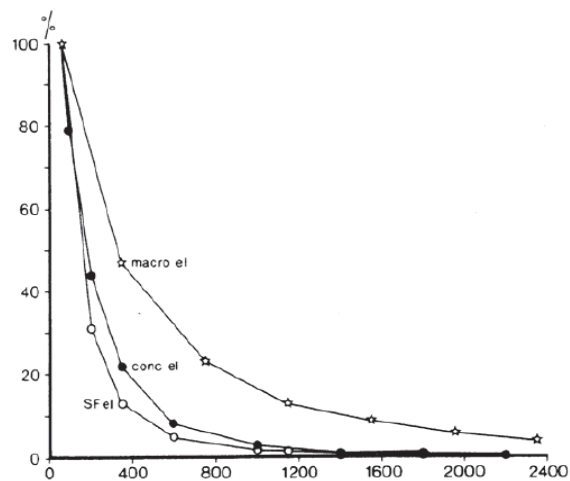

Figure 2: Concentric facial needle electrode



**FIGURE 3.** Relative recording uptake areas for the spike component of the MUP of three different electrode types. Schematic drawing based on simulation studies.<sup>24,25</sup> Copyright E. Stålberg, 2009.



**Fig. 2.2.** Relative peak-to-peak amplitude of a simulated SFAP at different distances from the fiber surface as measured by a SFEMG (square), concentric needle (round) and Macro (star) EMG electrode. The SFEMG AP was filtered with a 500 Hz high-pass filter. The APs in CNEMG and Macro EMG were not filtered. (Modified from [Stålberg, 1983] with permission.)

## Disadvantages of SFEMG Needle

- SFEMG electrodes are expensive,
- Develop increased impedance with use, and
- Must be sterilized for reuse, which does not entirely eliminate concern for infections main concern being prion infections.
- 

## What is Jitter?

- Neuromuscular jitter is defined as the random variability of the time interval between two MFAPs innervated by the same motor unit. It can originate from the terminal motor axon, NMJ and the segment of the muscle fiber between the NMJ and the recording electrode

## Criteria for accepting an AP as being generated by a single muscle fiber

- Biphasic, smooth shape that is constant on successive firings,
- amplitude greater than 200  $\mu\text{V}$
- rise time less than 300  $\mu\text{s}$ .

## ACTIVATION AND RECORDING TECHNIQUE

- Voluntary Activation.
- Stimulation

### Voluntary Activation

- Usually, jitter measurements are performed during voluntary activation of the muscle
- Less subject to technical problems but it requires more patient cooperation.
- With minimal voluntary activation, the needle is positioned until two muscle potentials (a pair) from a single motor unit are recognized.
- When a muscle fiber pair is identified, one fiber triggers the oscilloscope (triggering potential) and the second precedes or follows the first (slave potential).
- With voluntary activation, fifty consecutive discharges of a single pair is recorded.

### Jitter measurement techniques

- The jitter is expressed as the mean value of consecutive differences of successive inter-potential intervals (MCD)
- The normal mean MCD value varies from 10-50  $\mu\text{s}$  among different muscles.
- In certain situations the inter-potential interval (IPI) may be influenced by the preceding inter-discharge interval (IDI)
- May introduce an additional variability due to changes in the velocity of AP propagation in the muscle fibers.

- The effect of preceding depolarization's becomes constant at that point, provided no impulse blocking is present to produce an irregular discharge rate
- The effect of variable firing rates (during voluntary activation) can be minimized by sorting the IPIs according to the length of the preceding IDI, then calculating the mean of the consecutive IPI differences in the new sequence.
- The result is called the mean sorted-data difference (MSD).
- If the ratio MCD: MSD exceeds 1.25, then variations in the firing rate have contributed to the jitter, and the MSD should be used to represent the neuromuscular jitter.
- The MCD is used to express the jitter if the MCD:MSD ratio is less than 1.25
- **Neuromuscular blocking** is defined as the failure of one of the muscle fibers to transmit an action potential due to the failure of EPP to reach threshold.
- This usually happens when the jitter value is markedly prolonged, usually when MCD is more than 100 microseconds.

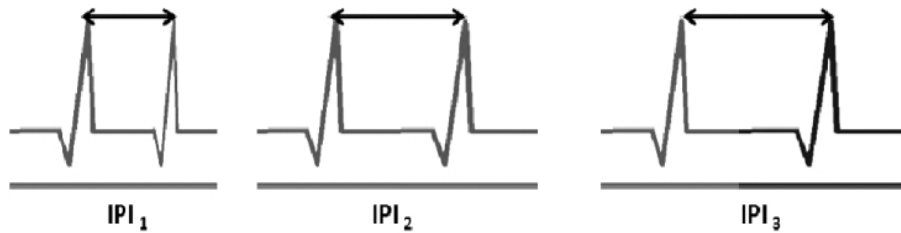

$$MCD = \frac{(IPI_1 - IPI_2) + (IPI_2 - IPI_3) + \dots + (IPI_{n-1} - IPI_n)}{n - 1}$$

**IPI= interpotential interval**  
**MCD=Mean value of consecutive difference**

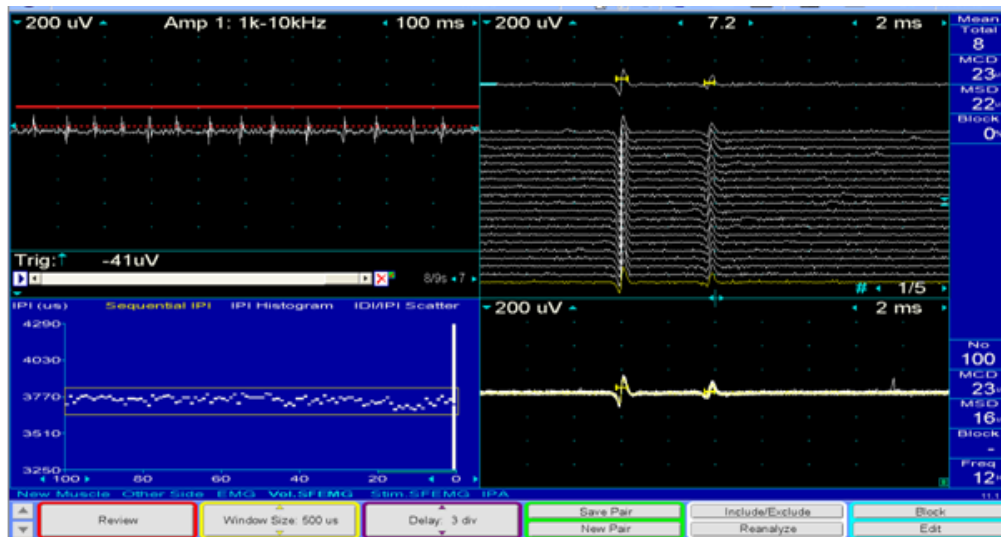

Voluntary SFEMG from frontalis muscle

# **EVOKED POTENTIALS**

# **BRAINSTEM AUDITORY EVOKED POTENTIALS**

## Introduction

BAEP or BAER measures the function of the auditory nerve and auditory pathways in the brain stem. The short latency BAER generally is used for clinical purposes. The test can be performed under sedation or under general anesthesia. Standard broadband click stimulation is used on the ear tested, while the contralateral ear receives masking noise of 30 to 40dB lesser intensity. Monaural stimulation is used. The click intensity should be 65 - 70 db above. Click perception threshold. A repetition rate of about 10Hz should be used.

## Electrode placement

An electrode is placed on each earlobe and at Cz.

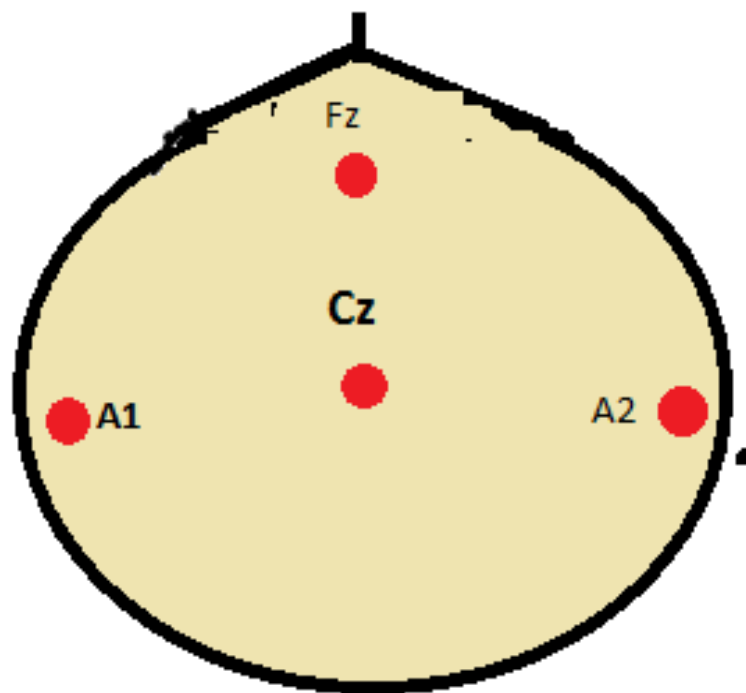

- . Wave I- Action potential of the cranial nerve (CN) VIII
- . Wave II- Cochlear nucleus (and CN VIII)
- . Wave III- Ipsilateral superior olivary nucleus
- . Wave IV- Nucleus or axons of lateral lemniscuses
- . Wave V- Inferior colliculus

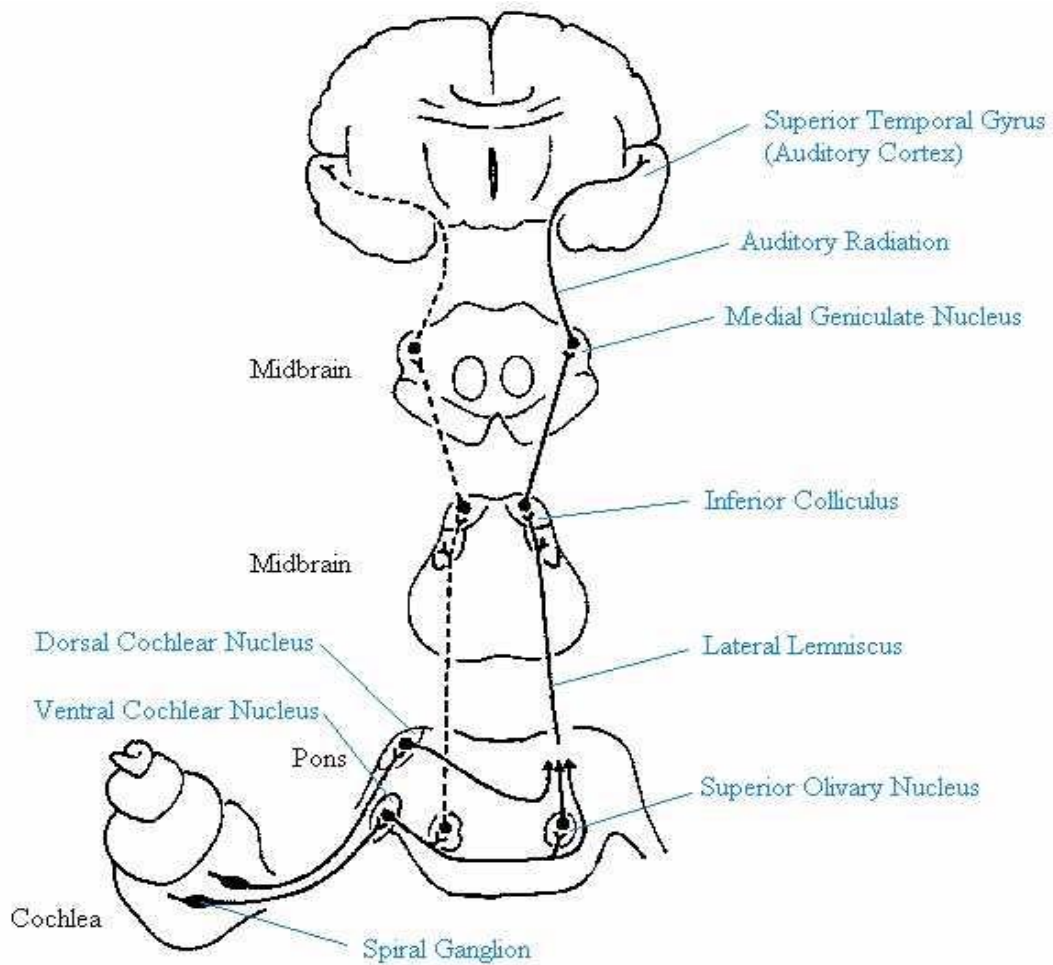

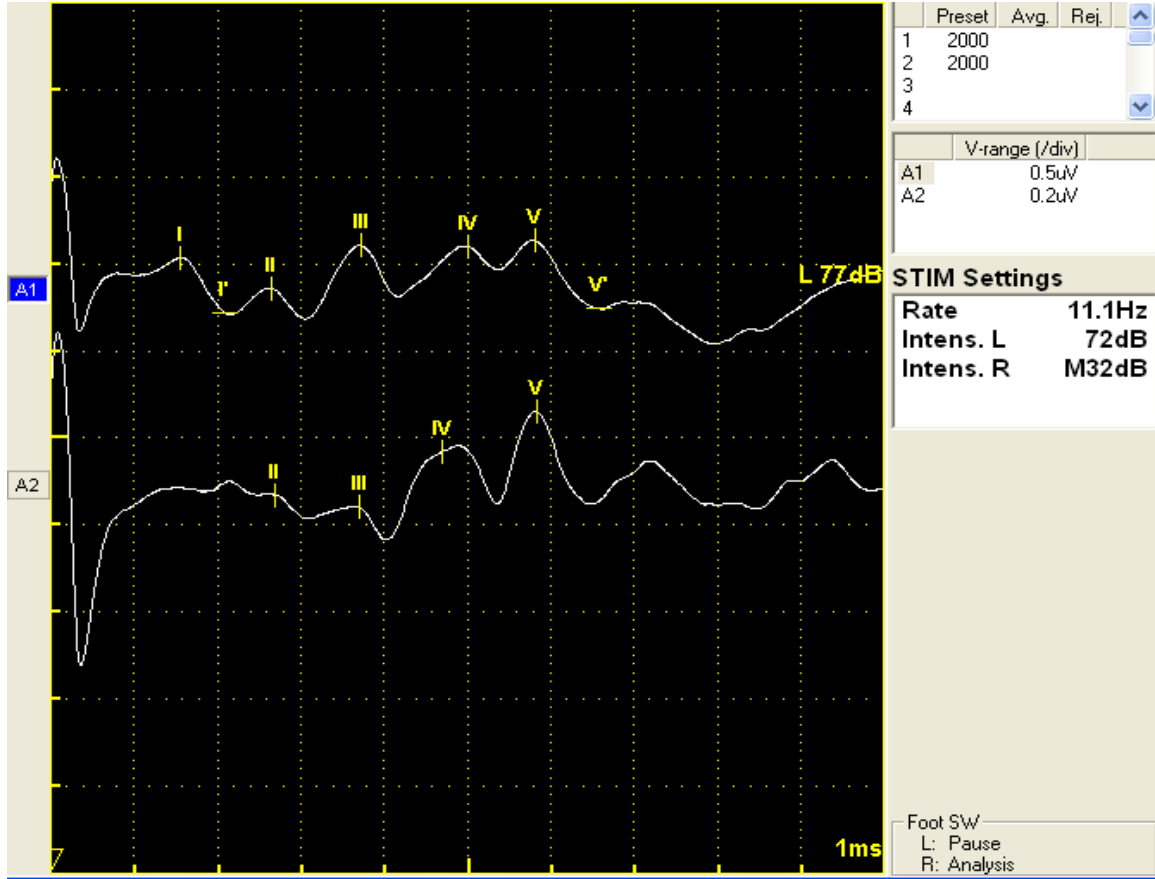

Factors influencing peak latencies of BAERs include age, sex, auditory acuity Stimulus repetition rate, intensity, and polarity. Rarefaction (i.e., earphone diaphragm moves away from the eardrum) produces an increase in wave I amplitude. In severe hearing loss, all wave forms may be delayed, wave I may be absent with waves II though V delayed, or all waveforms may be absent.

Patients with hearing loss BAER still can be obtained to assess central conduction time by increasing stimulation intensity.

BAEPs are useful in estimating or aiding in the assessment of hearing loss. The most commonly used method for this is evoked response audiometry. The frequency of stimulation is 50-70Hz, and at least 3 different intensities should be used. Wave V latency shifts are used to estimate the amount of hearing loss.

In children, especially those younger than 2 years, the BAEP can be used to screen those who might benefit from auditory amplification in order to achieve more normal speech and language development. However some children with a normal BAER have abnormal hearing. Showed middle latency abnormalities in some of these cases. The role of BAEP nevertheless is to identify those patients who could benefit from a hearing aid. Obviously with normal BAEP a hearing aid would not be useful to correct the hearing loss. Kern et al studied effects of insulin-induced hypoglycemia on the auditory brain stem response (ABR) in humans. ABRs were examined in 30 healthy men during euglycemia and after 20 minutes and 50 minutes of steady state hypoglycemia of 2.6mm induced with insulin. Hypoglycemia increased inter-peak latencies III-V and I-V, whereas changes in the latency of the wave I are not significant.

### **Technical aspects**

Filter band pass of 100-3000Hz is used. The first 10 ms are averaged, and 2-4000 responses may be averaged. At least 2 separate trails should be performed. The recording montage is at least, and usually, a 2 channel montage- channel 1 is ipsilateral ear to vertex and channel 2 is contralateral ear to vertex. Because of relative vertex positivity, the waveforms are recorded as upward deflections. The normal response is a series of waveforms within a time window of 10ms.

Clinically, the first 5 waves are used, with more significance placed on waves III and V. Peak and inter-peak latencies are measured, side-to-side differences are calculated, and wave I-V ratios may be used. Audiometry is very helpful and should be done within a reasonable time interval of the BAER. This helps the delineate any hearing loss that might influence the test results. Hearing loss in the 2000 - 4000Hz frequency range is especially important, since it may delay the BAEP.

### **Neonatal BAEP:**

Recording the neonatal BAEP is technically different from recording that of the adults. The skin is very sensitive, and special non-allergic tape should be used to fix the electrode. Collodion or other irritant chemicals are to be avoided. To avoid collapse of the earlobe and obstruction of the auditory canal of the premature babies, the earphone should be held above the ear. The earphone is best held by hand, and recording preferably should be performed with the neonate asleep. This helps reduce the high frequency components of the EEG that might interfere with BAEP recording. Because of the slower response, sweep should be set at 15-20ms and the low frequency cutoff filter at 20-30Hz.

BAEPs predominantly activate the pathways in the brain stem ipsilateral to the side of click stimulation. In particular, mid-upper pontine lesions tend to lead to ipsilateral BAER abnormalities. The structures involved in generation of BAEP may be more concerned with sound localization than with hearing itself.

## **BAEP in Intraoperative Monitoring**

### **USE;**

BAERs are used intraoperatively to assess the functional integrity of acoustic pathway structures, particularly those located in the brainstem. Typical situations requiring BAER monitoring include surgery for acoustic tumors, and procedures involving the cerebello-pontine angle and the posterior fossa

### **BAEP Features**

The basic BAER features used for intraoperative analysis include measurement of peak amplitudes, as well as peak and interpeak latencies [46, 20]. Occasionally, normal recordings may not contain all of the peaks. Wave V is the most reliable one and is present most of the times, along with wave I and III. Wave II is often missing, whereas wave IV may partially or completely merge with wave V

### **BAEP Interpretation**

Typically, after induction and final positioning of the patient, a set of baselines is obtained which remains on the screen for comparison throughout the case. Baseline responses should contain clear and reliable components, and should also be correlated with the clinical picture of the patient. For example, peripheral hearing loss may result in unclear or absent peaks.

During surgery, BAER interpretation criteria are based on the detection of significant changes, compared to the baselines, mainly in the amplitude and latency of peaks I and V, as well as the interpeak latencies from peak I to III and from III to V. These interpeak latencies represent the peripheral and central conduction time, respectively. BAERs are subcortical in origin and, thus, little affected by anesthetics or small changes in the anesthesia regime [20]. Therefore, even small changes may be significant. Traditionally, the most important criterion involves the latency and the amplitude of peak V. A change repeated twice in a row must be reported even if the latency has increased by only 0.5 msec. A shift of 1–1.5 msec usually indicates that some action must be taken.

# **VISUAL EVOKED POTENTIAL**

## Visual Evoked Potentials

The VEP tests the function of the visual pathway from the retina to the occipital cortex. It measures the conduction of the visual pathways from the optic nerve, optic chiasm and optic radiations to the occipital cortex. The most important fact is to consider that, although the axons from the nasal half of the retina decussate at the optic chiasm, the temporal axons do not. Therefore retro-chiasmatic lesions may not be detected by full field checkerboard stimulation. VEPs are most useful in testing optic nerve function and less useful in post chiasmatic disorders. In retro-chiasmatic lesions, the MRI is a more useful test. Partial field studies may be useful in retrochiasmatic lesions; however, they are not performed routinely in clinical settings. Also, note that the macula projects to the occipital pole, while the rest of the retina projects to the mesial calcarin cortex

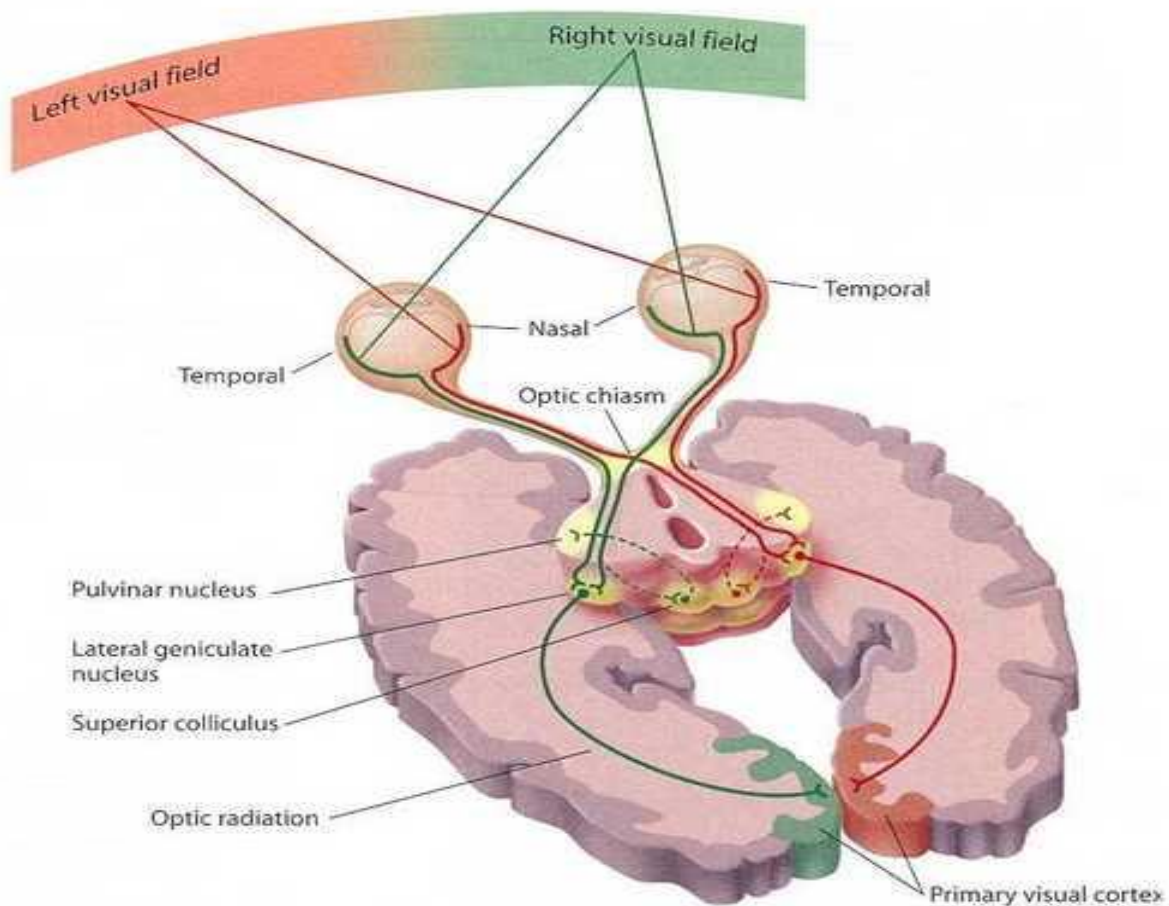

The VEP is very useful in detecting an anterior visual conduction disturbance. However, it is not specific with regard to the etiology. A tumor compressing the optic nerve, an ischemic disturbance, or a demyelinating disease may cause delaying the P100; only additional clinical history and, often, MRI are needed to uncover the etiology. The usual waveform is the initial negative peak (N1 or N75), followed by a large positive peak (P1 or P100) followed by another negative peak (N2 or N145).

Maximum value for P100 is 115 ms in patients younger than 60 years; it rises to 120ms thereafter in females and 125 ms in males. Even though, published norms are available in the medical literature, each individual laboratory should have its own norms to control for lab-to-lab variability in technique.

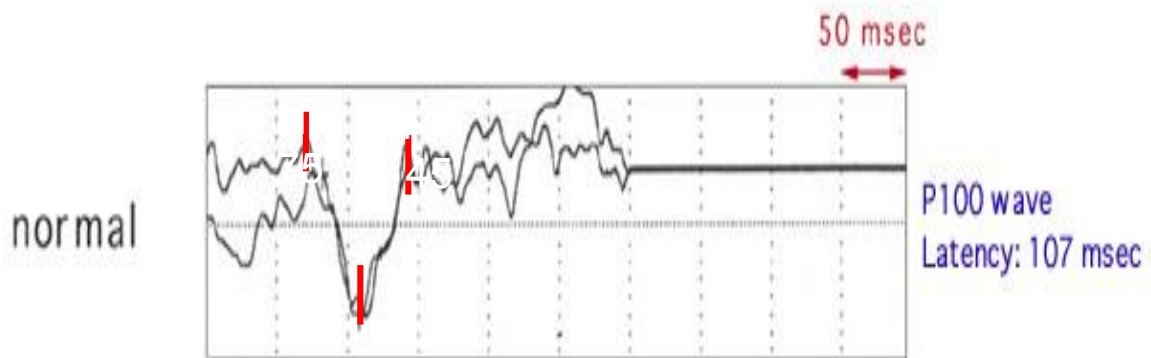

The “W” morphology, is most often a individual variation, although decreasing the stimulation frequency from the ubiquitous 2Hz -1 Hz usually converts the W shape into a conventional P100 peak Check size and alternation rate are the factors in this; the response can be manipulate to a W or a conventional **P100** response by changing these parameters. Large checks tend to produce VEPs similar to those produced by flash stimulation.

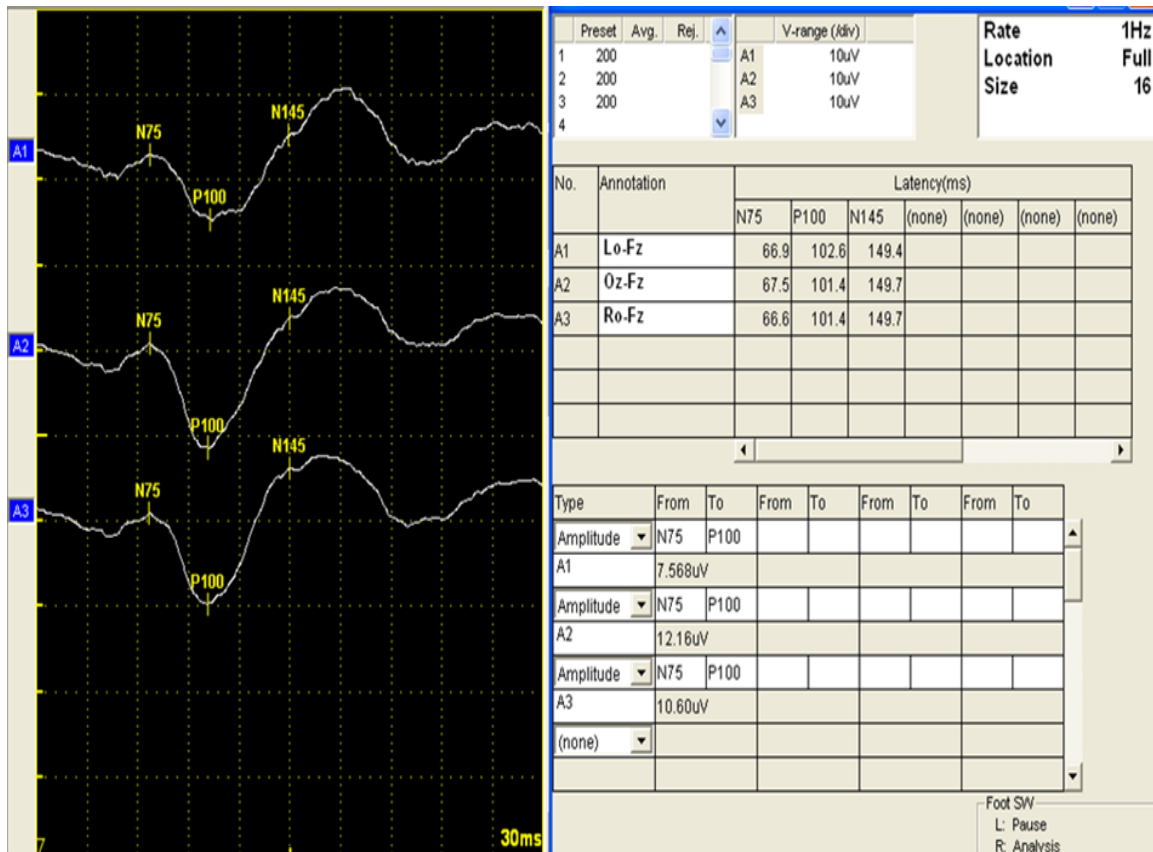

## Technical Aspects

Checkerboard pattern (or less often, flash) is used as stimulation. Responses are collected over OZ, 01, and 02 and with hemi field studies at T5 and T6 electrodes using the standard EEG electrode placement. Monocular stimulation is used to avoid masking of unilateral conduction abnormality. Sedation should not be used, and note should be taken of medications that the patient is taking regularly. Testing circumstances should be standardized, including seating distance of 70-100 cm from the monitor screen, giving a check size of approximately 30 seconds of visual angle. The vision should be corrected to the extent possible in case of a visual problem. Pupil's size and any abnormality should be noted. The P100 waveform is at its maximum in the mid occipital area. Stimulus rates of 1-2Hz are recommended, and filter setting should be 1- 200 Hz bandwidth.

The recommended recording time window (sweep length) is 250ms; 50 - 200 responses are to be averaged. A minimum of 2 trials should be given. The responses are averaged and the P100 positive polarity waveform that appears in the posterior head region is analyzed. The mean latency is about 100ms. Normative data should be assembled on a lab-by-lab basis.

## **VEP In Intraoperative Monitoring.**

VEPs are used intraoperatively to assess the functional integrity of the visual pathway during surgery for tumors or trauma involving the optic nerves, chiasm, optic tracts, and the occipital visual cortex. VEPs are most useful in cases involving the retro orbital and parasellar regions

### **VEP Features**

Intraoperative analysis of VEP features involves measurement of peak amplitudes, as well as peak and interpeak latencies. Typical flash VEPs contain two major positive components, *P1* and *P2*, found at about 100 and 170 msec after stimulus onset, respectively. Each of the components is preceded by a negative one, *N1* and *N2*, at about 70 and 140 msec, respectively. The latter components however are less clear and stable. All components are generated by the visual cortex

### **Interpretation**

In general, after induction and final positioning of the patient, a set of baselines is obtained which remains on the screen for comparison throughout the case. Baseline responses should contain clear and reliable components, and should also be consistent with the clinical picture of the patient.

During surgery, interpretation criteria are based on detection of reliable changes (compared to baselines) that affect the overall morphology of the response, their latency, as well as eventual asymmetry in component amplitude and latency between the left and right eyes . A change can be considered significant if (1) results in a 50% amplitude reduction or complete loss of the VEP, or (2) the maximum latency shift is more than approximately 40–50 msec . However, because of the great variability of the flash VEPs, the only reliable criterion for abnormality is the complete absence of the components resulting from monocular stimulation. Several studies have shown the high incidence of false positives that can be as high as 95% of the cases, thus making the intraoperative use of VEPs questionable

## **SOMATOSENSORY EVOKED POTENTIALS**

## **Introduction**

Somatosensory evoked potentials (SSEPs) consist of a series of waves that reflect sequential activation of neural structures along the somatosensory pathways following electrical stimulation of peripheral nerves. In clinical practice, SSEPs are elicited typically by stimulation of the median nerve at the wrist, the common peroneal nerve at the knee, and/or the posterior tibial nerve at the ankle and recorded from electrodes placed over the scalp spine, and peripheral nerves. The dorsal column lemniscus system is the major anatomical substrate of the SSEPs within the CNS.

SSEPs are used for clinical diagnosis in patients with neurologic disease and for intraoperative monitoring during surgeries that place parts of the somatosensory pathways at risk. Abnormal SSEPs can result from dysfunction at the level of the peripheral nerve, plexus, spinal root, spinal cord, brain stem, thalamo-cortical projections, or primary somatosensory cortex. Since individuals have multiple parallel afferent somatosensory pathways (e.g. anterior spino-thalamic tract, dorsal column tracts within the spinal cord), recordings of SSEPs can be normal even in patients with significant sensory deficits.

SSEPs depend on the functional integrity of the fast-conducting, large-diameter group IA muscle afferent fibers and group II cutaneous afferent fibers, which travel in the posterior column of the spinal cord. When a mixed peripheral nerve (with both sensory and motor components) is stimulated, both group IA muscle afferents and group II cutaneous afferents contribute to the resulting SSEP. Selective ablation of the dorsal column of the spinal cord abolishes the SSEPs generated rostral to the lesion. Diseases of the dorsal columns in which joint position sense and proprioception are impaired invariably are associated with abnormal SSEPs.

## **Stimulus Location**

For recording median nerve SSEPs, the nerve is stimulated at the wrist. The anode is placed just proximal to the palmar crease, and the cathode is placed between the tendons of the palmaris longus muscle, 3 cm proximal to the anode.

Ulnar nerve SSEPs are preferred to median nerve SSEPs for assessing the lower cervical spinal cord segment since the ulnar nerve originates from spinal roots C8-T1, whereas the median nerve originates from C6-T1.

For recording posterior tibial nerve SSEPs, the nerve is stimulated at the ankle, with the cathode midway between the Achilles tendon and the medial malleolus and the anode 3 cm distal to the cathode.

Peroneal nerve SSEPs, the common peroneal nerve is stimulated at the knee, with the cathode inferior to the leg crease just medial to the tendon of the biceps femoris muscle and the anode 3 cm distal to the cathode.

**In the lower limb, posterior tibial SSEPs are preferred because of the following:**

- In clinical diagnostic use, they are larger and less subject to variability.
- In intraoperative settings, they produce smaller muscle contractions with larger SSEP amplitudes
- In intraoperative settings, electrodes at the ankle are more easily accessible than those at the knee the peripheral compound action potential (CAP) is recorded easily at the popliteal fossa.

**Stimulation**

Intensity of the selected nerves are stimulated with monophasic square pulses, 100-300 microseconds in duration. Stimuli are delivered by using either a constant voltage or a constant current stimulator. The contact impedances of the stimulating electrodes should be kept low for the following reasons:

- To minimize patient discomfort
- For more effective nerve stimulation, if a constant voltage stimulator is used

To avoid electrical artifacts with constant current stimulation in the clinical setting, the stimulus intensity is set high enough to produce a consistent muscle twitch, which usually is tolerable to the patient. Because the patient is anesthetized during intraoperative SSEP monitoring, higher stimulus intensities can be used and are advisable to provide a safety margin in case the efficacy of nerve stimulation decreases during surgery.

Stimulus Rate Rapid stimulus delivery rates should be avoided, as they degrade the waveforms of SSEPs. In clinical settings, a rate of 3-6 stimuli per second usually is used. Rates that are exact sub harmonics of 50 Hz (eg: 5Hz) should be avoided, since their use would lead to contamination of the mean SSEPs by large artifacts of 50-Hz line frequency SSEPs typically are recorded by using standard EEG electrodes affixed with tape or collodion, electrode caps containing multiple recording electrodes also can be used. Scalp needle electrodes are not used routinely because of their high impedance, risk of infection, and discomfort to the patient. Recording electrode impedances should be kept below 5000 ohms and should be as uniform as possible across the electrodes to maximize common-mode rejection and minimize noise pickup. Also, placing the ground electrodes on the stimulated limb helps reduce the electrical stimulant artifact. Typical recording amplifier filter settings for SSEPs are 30-3000 Hz. Diagnostic SSEP studies should be performed using the same filter settings used to record normative data.

Several characteristics of SSEPs can be measured including onset latency, inter-peak latency, morphology (i.e., presence and absence of components), and dispersion. Onset latency is the easiest SSEP feature to measure and standardize, but it gives rather limited information. Other characteristics (i.e., morphology and dispersion) are more variable and difficult to interpret.

Absolute SSEP latencies vary with limb length. Inter-peak (i.e., transit) times are reliable parameters that are independent of limb length and usually independent of peripheral nerve disease. Aging is associated with some prolongation of SSEP latencies. Latencies are considered abnormal when they are more than 3 standard deviations above the mean of the normative data.

### Recording electrodes sites

Anatomical landmarks identify recording electrode sites. Those on the head are defined using the international 10-20 systems, or its extension, the 10-10 systems. Electrode CP3 is midway between C3 and P3, and electrode CP4 is midway between C4 and P4. CPi denotes either CP3 or CP4, whichever is ipsilateral to the stimulated limb; CPC is the contralateral Centro parietal scalp electrode. CPz is midway between Cz and Pz. Recording electrodes over the spine are placed in the midline, and they are labeled with the name of the vertebral body they are placed on followed by the letter S, for example:- T10S.

Recording montages for cortical SSEP components are either cephalic bipolar, in which both electrodes are placed over the head, and referential, in which a reference electrode is placed at a noncephalic site. Cephalic bipolar montages have the advantage of being relatively free from noise and are preferred for routine clinical use.

For upper limbs SSEP studies, electrodes are placed over both Erbs point (ie:-the angle between the clavicular head of the sternocleido mastoid muscle and the clavicle), both ipsilateral and contralateral to the stimulus (labeled EPi and Epc). For lower limb SSEP studies, Ic denotes an electrode placed over iliac crest.

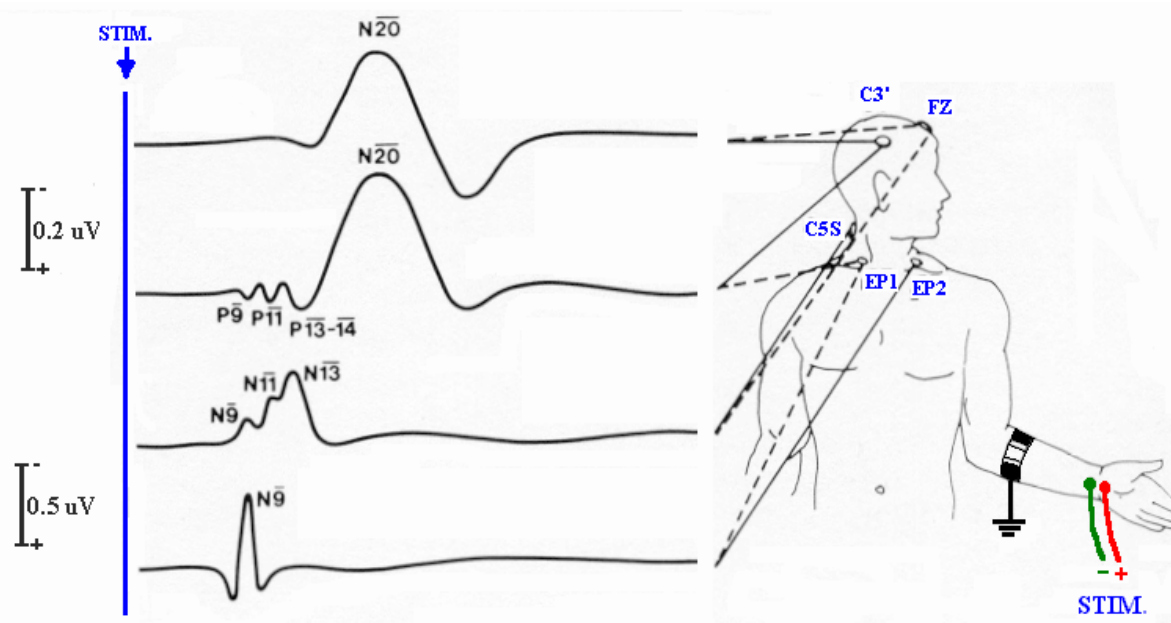

## Normal values

<b>Site</b>	<b>Peak latency (msec)</b> ( mean +/- I SD )	<b>Side – to - side latency difference (rang, msec)</b>	<b>Peak Amplitude ( micro V)</b> (mean +/- I SD)	<b>Side - to - side amplitude difference (range, micro V)</b>
<b>Elbow (N4)</b>	<b>4.3 +/- 0.3</b>	<b>0.24 – 0.99</b>	<b>3.4 +/- 0.7</b>	<b>0.11 – 2.54</b>
<b>Shoulder (N9)</b>	<b>9.9 +/- 0.6</b>	<b>0.44 – 1.74</b>	<b>2.1 +/- 0.6</b>	<b>0.17 – 0.94</b>
<b>Cervical</b>	<b>12.1 +/- 0.2</b>	<b>0.47 – 1.89</b>	<b>1.5 +/- 0.4</b>	<b>0.14 – 1.31</b>
<ul style="list-style-type: none"> <li>• 1<sup>st</sup> peak(N12)</li> <li>• 2<sup>nd</sup> peak(N13)</li> </ul>	<b>13.4 +/- 0.3</b>	<b>0.43 - 1.52</b>	<b>1.9 +/- 0.3</b>	<b>0.16 – 1.28</b>
<b>Scalp</b>	<b>19.2 +/- 1.1</b>	<b>0.72 – 3.10</b>	<b>0.6 +/- 0.2</b>	<b>0.19 – 1.81</b>
<ul style="list-style-type: none"> <li>• N1(N20)</li> <li>• P1(P25)</li> <li>• N1 – P1</li> </ul>	<b>25.2 +/- 2.1</b>	<b>1.08 – 4.05</b>	<b>2.1 +/- 0.9</b>	<b>0.21 – 2.31</b>

## Spinal SSEP

Electrodes placed over the spine as described above record spinal SSEPs. They are considerably smaller in amplitude than SSEPs recorded over the scalp. However, the difference in latency between the scalp and the cervical or limb SSEPs is a measure of central sensory conduction, assessment of which remains the chief clinical goal of recording SSEPs. Thoracolumbar spinal SSEPs are even smaller than cervical spinal SSEPs and can be difficult to record in obese subjects SSEP components typically are named by their polarity and typical peak latency in the normal population. For example, N20 is a negativity that typically peaks at 20 milliseconds after the stimulus. The normal latency value for a component in a particular individual may be different from that implied by the component's name, because the lengths of the peripheral nerve and spinal conduction pathways, which vary with the patient's stature and age influence the latencies of the SSEP components.

The nomenclature of an evoked-potential component is inconsistent in the literature because the recording montage is not specified with the peak latency and 'polarity'. For example, a CPi-EPc linkage following median nerve stimulation records a P14, while an EPc-CPi linkage records an N14.

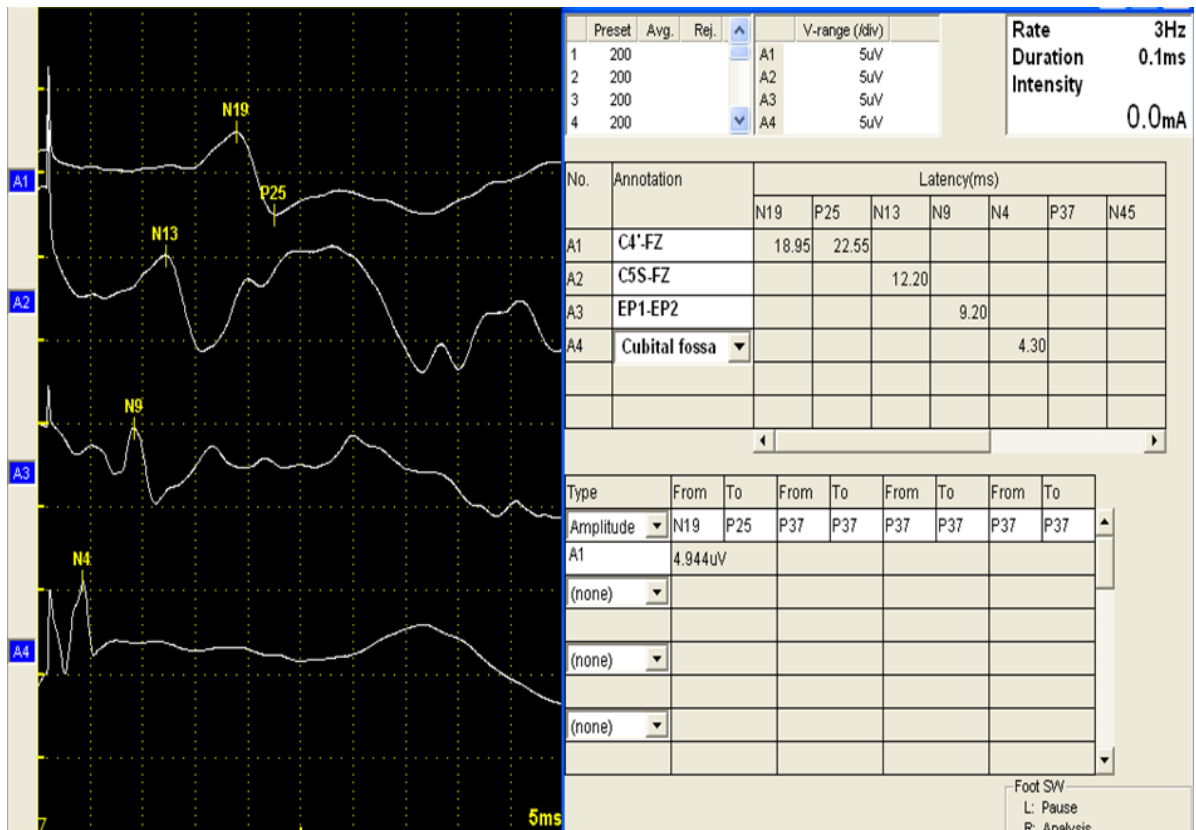

## **SSEP in Intraoperative Monitoring**

A comprehensive discussion of the interpretation of intraoperative evoked potential data is beyond the scope of this presentation and the reader is referred to other sources. When surgical maneuvers compromise neural tissue, SSEP components may show significant amplitude attenuation before their latencies become prolonged. Thus both amplitudes and latencies should be evaluated during intraoperative monitoring. No universally accepted standard exists for what constitutes a significant change, but a 50% decrease in the amplitude of an SSEP component or a 10% increase in its latency often are used as threshold criteria (SSEP amplitudes generally show more run-to-run variability than SSEP latencies).

Anesthetic agents are probably the most common cause of intraoperative SSEP changes. In general, the longer the latency of an SSEP component and the more synapses between the stimulation site and component's neural generator, the greater is the degree to which that component will be affected by anesthetic agents. Thus, anesthetic effects may alter the cortical SSEPs while sparing the far-field SSEPs mimicking surgery-related dysfunction of the cerebral cortex or of the pathways from the brain stem to the cerebral cortex. Personnel performing intraoperative monitoring must pay careful attention to the anesthetic regimen and should record it periodically on their data logs.

Personnel performing intraoperative monitoring also should periodically note and log the temperature and blood pressure of the patient, which also can affect the electro physiologic signals. Anesthetic-induced changes typically are bilateral; this can help distinguish anesthetic-related from surgery-related SSEP changes when the latter are expected to be unilateral but not when surgical manipulations can damage afferent sensory pathways bilaterally (e.g., bilateral spinal cord damage during surgery for scoliosis)

### Uses

Somatosensory evoked potentials are used intraoperatively to:

- Monitor blood perfusion of the cortex or the spinal cord (e.g., during an aneurysm clipping).
  - Monitor the structural and functional integrity of the spinal cord during orthopedic or neurological surgery (e.g., for scoliosis or a spinal tumor).
  - Monitor structural and functional integrity of peripheral nerves (e.g., sciatic nerve during acetabular fixation), spinal nerve roots (e.g., during decompression in radiculopathy), and peripheral nerve structures (e.g., the brachial plexus).
- Determine *functional* identity of cortical tissue (e.g., one can separate the sensory from motor cortex by identifying the central sulcus).

## **SSEP Interpretation**

After induction and final positioning of the patient, a set of baselines is obtained which remains on the screen for comparison throughout the case. Baseline responses should be of familiar morphology and contain clear and reliable components. The baselines should also be consistent with the clinical picture of the patient.

During surgery, interpretation criteria are based on detection of reliable and significant changes compared to the baselines established at the beginning of the case. Changes mainly involve the amplitude and latency of the SEP components recorded at different levels. A change is *reliable* if it is repeatable at least twice in a row; and it is *significant* if the amplitude has decreased by at least 50% or the latency has increased by at least 10%

# **Motor Evoked Potentials**

## **Introduction**

Noninvasive elicitation of motor evoked potentials (MEPs) was made possible by Merton and Morton in 1980. They designed a high-voltage transcranial electrical stimulator that excited the motor cortex using cutaneous electrodes, which were placed over the scalp. After transcranial electrical stimulation (TES), a contraction of contralateral muscles is recorded in a conscious subject.

The usefulness of this method has remained limited by the local discomfort of the electrical currents that are applied over the scalp. An exception to this limitation is its use for intraoperative monitoring.

The development of transcranial magnetic stimulation (TMS) in 1985 opened new possibilities for MEP studies. Barker et al created a new type of cortical magnetic stimulator, based on the principle of electromagnetic induction. The device was composed of a main unit, which contains a bank of heavy duty capacitors the hand held part was freely moveable so that it could be placed over any part of the body. Although magnetic stimulation was used first to stimulate the peripheral nervous system (PNS) and muscles, cortical stimulation has become the focus of many studies.

## **Motor Cortex**

The main motor cortical area is located on the anterior wall of the central sulcus and the adjacent portion of the pre-central gyrus. This area corresponds to area 4 of Brodmann. It is rich in pyramidal neurons, which provide the anatomical substrates for the motor output function of area 4.

Electrical stimuli over area 4 produce activation of contralateral muscles; the face, mouth, and hand muscles occupy about two thirds of the primary motor area. The size of cortical representation of muscles is less a function of the muscle mass than of precision of the muscle movements. Secondary and tertiary areas of motor function can be mapped roughly around the primary motor cortex.

The primary motor cortex contributes more fibers to the cortico-spinal tract than any other region. Numerous observations support contributions from several other areas, including the frontal and parietal cortices. Ipsilateral projections are far less numerous than contralateral, estimated between 1.8-5.9% of corticospinal connections.

## **Pyramidal tract**

Fibers of the corticospinal tract and corticobulbar tract originate from the sensorimotor cortex around the central sulcus. The human pyramidal tract contains over 1 million fibers. Most fibers are myelinated and have a small diameter (1-4 mm) only a small portion (3-5%) are large-diameter fibers (10-22 mm) that originate in Betz cells from area 4.

In humans, only 5% of the fibers of the corticospinal tract originate from Betz cells in area 4. The concept of pyramidal pathways with fibers originating only from Betz cells in the primary motor cortex has been invalidated. A large part of the corticospinal neurons have nonmotor function, especially those originating in sensory or associative areas.

## **Sub cortical projections of the pyramidal pathway**

The Pyramidal fibers converge into the corona radiata toward the posterior arm of internal capsule. In the pons they divided into multiple longitudinal pathways which merge in the medulla oblongata to form the pyramidal tract after branching out efferences to motor nuclei of cranial nerves. At the junction between the medulla oblongata and the spinal cord, 75-90% of the fibers cross through the midline to constitute the crossed (i.e., indirect) pyramidal pathway. The remaining fibers comprise the uncrossed (i.e., direct) pyramidal pathway. A large part of direct pyramidal tract fibers actually cross the midline at the spinal cord level (i.e., through the white anterior commissura), so that its projections are bilateral.

## **Magnetic Stimulation**

Magnetic stimulation of the nervous system can occur only in the setting of a rapidly changing magnetic field. Subjects exposed to a constant field strength (e.g: magnetic resonance imaging [MRI]) do not experience stimulation of nervous tissue. The intensity of the secondarily produced electrical field in nervous tissue (and of the stimulation) is related to the speed of change in magnetic field strength.

Formation of the magnetic pulse starts within the main unit of the stimulator, where a large bank of heavy duty capacitors is electrically charged. When triggered, these capacitors rapidly discharge through a cable into the hand held coil, producing a brief burst of high current (up to 4000 volts [V] or several 1000 amperes [A]). The current that moves through the hand-held coil produces a large magnetic field (1-3 T) that lasts only 50-200 milliseconds.

The stimulating coil consists of tightly wound and well-insulated copper coil. As a result of the brief- magnetic field induced from the coil a secondary electric field circulates in the opposite direction to the magnetic field is produced. The strength of the electric field is related in part to the first derivative of the magnetic flux over time: the more rapid the change in magnetic field, the stronger the intensity of the secondary electric field and nervous stimulation.

Most commercially available stimulators can produce stimulations at a rate as high as 5 Hz, although some can produce repetitive stimulations as high as 50 Hz. A big advantage of magnetic stimulation over electrical stimulation is its ability to penetrate tissues regardless of electrical resistance. The drop-off is essentially the same for air, bone, fat, muscle, and saline.

The magnitude, waveform, and rise time of the magnetic field are important parameters of the stimulation. The diameter, shape, and thickness of the coil are also important. Because of these multiple variables, the measurement of intensity of stimulation usually is expressed as a percentage of the maximal output of the stimulator.

In choosing coils, the trade-off is between strength and focality of stimulation. Coil diameter may vary between 5 cm and 15 cm. Large-diameter coils stimulate over a wider area but are less focal than small-diameter coils. With the round coils, the highest intensity electric field is measured at the edges of the coil with lower intensities in the center. To obtain more focality, use of a butterfly (also called "figure of 8" coil) is recommended. Their focality makes them particularly suitable for the performance of mapping out the upper limb and hand musculature.

## **Electrical Stimulation**

Electrical stimulators have a simpler design, than, magnetic stimulators. The stimulation is transmitted through cutaneous electrodes. The main advantage is a better depth of penetration, allowing direct spinal cord stimulation. The main limitation is the local discomfort that is created by the stimulation.

Electrical stimulators contain a capacitor that produces constant current, high voltage pulses of brief duration for percutaneous stimulation. The output current range is 0-1000 mill amperes, from a source voltage as high as 400 V. The pulse width range can be varied from 50 milliseconds to 2 milliseconds. The voltage is kept constant during the stimulation but the intensity of stimulation depends on the skin impedance.

## **MEP In Intraoperative Monitoring**

Somatosensory EP monitoring measures the integrity of sensory tracts only. Therefore, selective damage to motor tracts may go undetected. Additionally, since the ventral and dorsal portions of the spine are supplied by different blood vessels, ischemia affecting the motor tracts only will not be detected by SEPs. Thus, MEPs are used intraoperatively to protect the structural and functional integrity of the motor tracts in the spinal cord

### **MEP Features**

Neurogenic MEPs recorded, for example, at the popliteal fossa, in addition to the *orthodromic* motor component, contain an *antidromic* sensory component. The former results from intentional stimulation of the motor tracts in the spinal cord and travels in the direction of normal signal propagation, while the latter results from unintentional stimulation of the sensory tracts in the spinal cord and travels in the opposite direction of normal signal propagation. However, because of differences in conduction velocity in the sensory and motor tracts, the motor component leads the sensory one, allowing for proper discrimination of the two types of activity

# **VAGUS NERVE STIMULATION**

## **Introduction**

Vagus Nerve Stimulation is a type of treatment for epilepsy that involves a stimulator - called a pulse generator - which is connected, inside the body, to the left vagus nerve. The stimulator sends regular, mild electrical stimulations to this nerve.

The electrical signals from the stimulator travel through the lead to the electrodes, which are wrapped around the vagus nerve in the neck. From here, the signals travel up into parts of the brain that are thought to be involved in causing seizures

The VNS Therapy system consists of the VNS Therapy Pulse Generator, the Bipolar Lead, the programming wand and software and the tunneling tool. The VNS Pulse Generator (the vagus nerve stimulator) and Bipolar Lead are surgically implanted in a procedure which takes from 30 to 90 minutes, during which time the patient is under general, regional or local anesthesia. The VNS Pulse Generator is surgically implanted in a subcutaneous pocket in the upper left chest. The Bipolar-Leads connected to the VNS Pulse Generator and attached to the vagus nerve in the lower left side of the patient's neck. The patient is generally admitted to the hospital the day of surgery and discharged the same or following day

## **Vagus nerve**

The vagus nerves are a pair of nerves that start in the brain and run through other parts of the body. They send and receive messages, between the brain and the body.

## **Aim of VNS**

VNS aims to reduce the number, length and severity of seizures. For some people their seizures become much less frequent, for others it may reduce their seizures a little, and for others it has no effect. For some people VNS reduces the length or intensity of their seizures, but this does not happen for everyone. It may also reduce the time it takes to recover after a seizure. It is unlikely to completely stop seizures and it does not 'cure' epilepsy.

The effect of VNS does not happen straightaway; it can take up to 2 years for it to have an effect on someone's seizures. VNS is used alongside anti-epileptic drugs (AEDs) not instead of them. If VNS works, it may be possible to reduce a person's AEDs over time.

## **VNS Pulse Generator**

The Pulse Generator of the VNS Therapy system is an implantable, programmable, cardiac pacemaker-like signal generator designed to be coupled with the bipolar lead to deliver electrical signals to the vagus nerve. The VNS Pulse Generator (vagus nerve stimulator) employs a battery which has an expected life of approximately eight to ten years at standard stimulation parameters. Upon expiration of the battery, the VNS Pulse Generator is removed and a new generator is implanted in a short, out-patient procedure using local anesthesia.

Because of the size of the stimulator there will be a small lump where it lies, and a small scar where it was put in. A lead connects the stimulator in the chest to the vagus nerve in the left side of the neck. Because the electrodes are coiled around the nerve in patient's neck, there will be a small scar where they are inserted, usually in the fold of patient's neck

## **Bipolar Lead**

The lead incorporates patented electrodes which are self-sizing and flexible, minimizing mechanical trauma to the nerve and allowing body fluid interchange within the nerve structure. The lead's two electrodes and anchor wrap around the vagus nerve and the connector end is tunneled subcutaneously to the chest where it is attached to the VNS Pulse Generator. The leads, for the VNS Therapy, are available in two sizes of inner spiral diameter to ensure optimal electrode placement on different size nerves.

## **Programming Wand and Software**

The VNS Therapy system includes a proprietary programming wand and software, used to interrogate the device and to transmit programming information from a personal computer to the VNS Pulse Generator via electromagnetic signals. These products are compatible with both Pentium and non-Pentium based platform personal computers. Programming capabilities include modification of the VNS Pulse Generator's programmable parameters (pulse width, output current, signal frequency and stimulation duration and interval) and storage and retrieval of telemetry data. The VNS Therapy programming wand can be connected to a standard personal computer using a serial connector.

## **Tunneling Tool**

The tunneling tool is a single use sterile, disposable surgical tool designed to be used during surgical placement of the Bipolar Lead. This VNS Therapy tool is used for subcutaneous tunneling of the lead assembly between the nerve site in the neck and the VNS Pulse Generator site in the chest.

## **Accessory Pack**

The VNS Therapy system also includes an Accessory Pack comprised of one Pulse Generator resistor assembly used to test the function of the device prior to implantation, the VNS Bipolar Lead tie-downs, one hex screwdriver, two setscrews and setscrew plugs.

## **Working of VNS during seizure**

Some people have a warning or aura a type of simple partial seizure-that tells them that they are going to have a seizure. When this happens, passing a special magnet over the stimulator gives extra stimulation. This may stop the aura from developing into another seizure, or may reduce the length of the seizure, or the recovery time afterwards. This magnet can be worn on patient's wrist like a watch, or on patient's belt. For people who have no warning before a seizure, someone else could use the magnet when a seizure happens

## **Side effects**

VNS can cause side effects but usually only during the time that the nerve is being stimulated. Side effects may not happen for everyone but include discomfort in the throat, a cough, difficulty swallowing and a hoarse voice.

Side effects usually reduce over time and do not usually mean that the VNS has to be switched off. Your doctor or nurse can adjust the settings if the side effects are a problem to you. If the side effects cause problems at certain times, such as difficulty swallowing when you are eating, then holding the magnet over the stimulator for a few seconds briefly stops the stimulation, which should stop the side effects. VNS does not affect, and is not affected by, anti-epileptic drugs. Some people feel that VNS enhances their mood, memory alertness, and may also help reduce depression or have a positive effect on their quality of life.

## **Precautions**

If patient have VNS and need an MRI, it is important that everyone involved with the scan is aware of patient's VNS, to decide if the scan can be done. Magnetic Resonance Imaging (MRI) uses strong magnetic fields to take images of the brain. As the VNS includes metal, there is a risk that the magnetic field in the MRI machine could cause the electrodes to heat up. The risk of this depends on the MRI machine used. Some types of MRI is may be possible. If they just scan patients head rather than scanning patient's whole body and if they do not scan patient's neck or chest - where the VNS lies.

If the scan can be done, the VNS will need to be switched off before the scan, and turned back on again afterwards. X-Rays and CF scans do not affect and are not affected by VNS

**VISUAL ACUITY  
&  
VISUAL FIELDS TESTING  
(OPTOMETRY)**

## **Introduction**

Optic nerve is the most important nerve which carries visual impulses from the retina to the optic chiasm and on the optic tract to the lateral geniculate body to act as the afferent pathway for the papillary light reflex by means of fibers traveling to the superior colliculus of the mid brain. The major test performed in the optometry is:

- (i) To measure the acuity of vision and to determine any defect is due .to local ocular disease.
- (ii) To chart the visual fields

## **VISUAL ACUITY**

The standard Snellen's Type of charts are used for testing distant vision and the Jaegers types cards for near vision. The Snellen's type chart is placed, evenly illuminated, 6 meters (20 feet) from the patient, who covers one eye and is asked to read the smallest line he/she can see accurately. Acuity is recorded as a fraction (6/24). The numerator indicates the distance at which the patient has to be from the chart in order to read the same type that the normal person could read at a distance indicated by denominator. 6/5 - 6/6 are within the average normal range. The Jaegers type card must be held one foot from the patient's eye and a similar test is then carried out. The different types are labeled as N6, N24etc according to their size. The average acuity lies between N6 and N9.

## **VISUAL FIELD**

Charting the visual field is the most important method of locating a lesion in the visual pathways or of interpreting certain fundus appearances, yet in clinical notes it is often difficult to find evidence that any attempt has been made to examine them at all. The purpose of the test is to chart the periphery of the visual fields; to determine the position, size and shape of the blind spot and any abnormal scotoma; to compare any defects shown with those abnormalities known to be reproduced by lesions at specific points in the visual pathways. The principles by which lesions are located are thus illustrated by comparing a diagram of the visual pathways with the principal field defects.

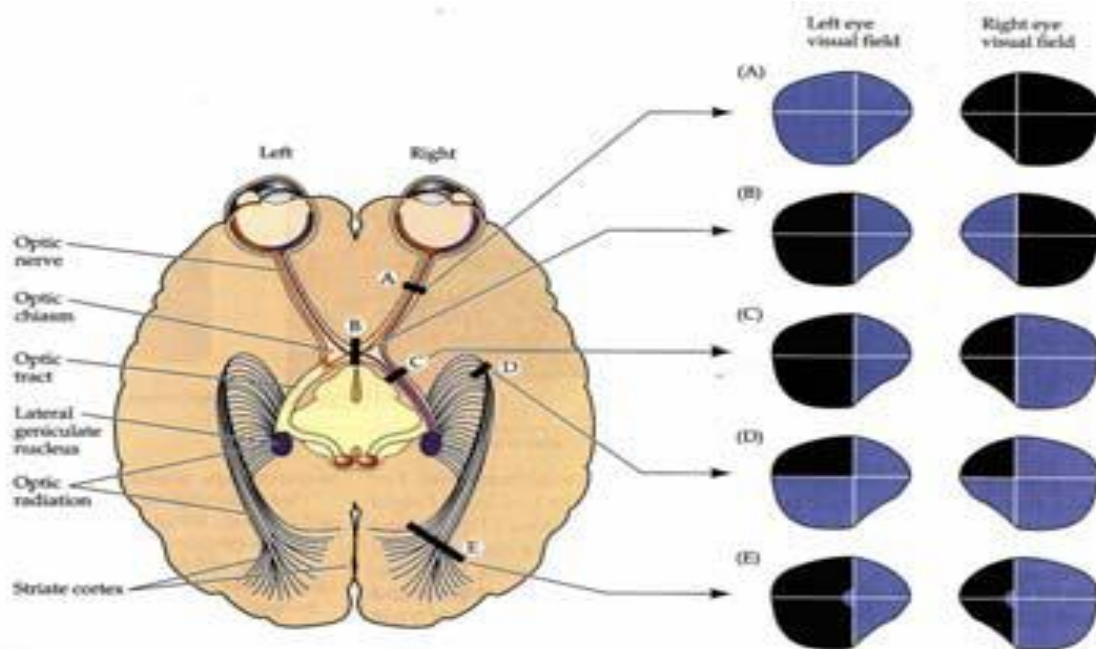

**Normal**

patient's ID : RARICHAN  
 file number : 366215  
 birth date : 20/05/1960

Rx :  
 exam. date : 20/07/2015  
 exam :

**VISUAL FIELD EXAM**

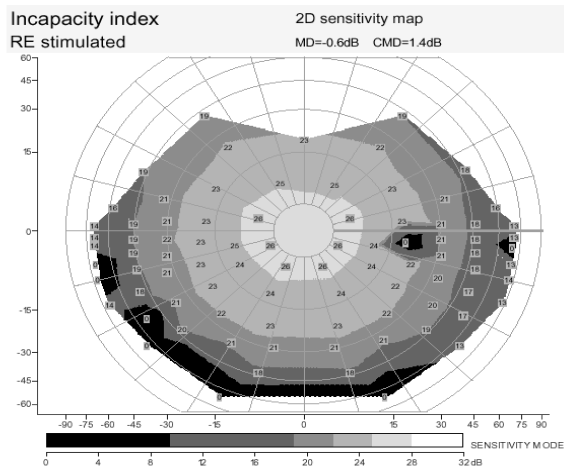
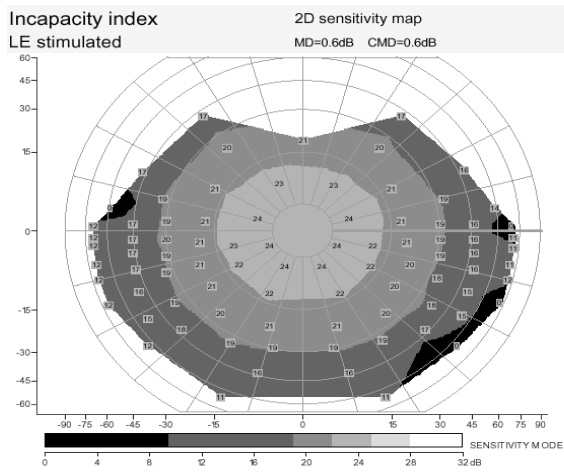

## **BOTULINUM TOXIN INJECTION**

Botulinum toxin, a toxic protein produced by the bacterium *Clostridium botulinum*, causes botulism, a deadly form of food poisoning. But in tiny quantities, the toxin acts as a muscle-relaxing agent by blocking the release of acetylcholine in the nerve endings. Acetylcholine transmits electrical messages between the brain and the muscles. When the botulinum toxin blocks its release, the messages are not delivered. As a result, muscle contractions and associated pain are reduced.

Minute amounts of the toxin are injected directly into the muscle responsible for the spasms. The toxin weakens the muscle, but does not paralyze it, and allows the affected area to resume a more normal position. Pain from prolonged muscle contractions is eased. The treatments can be used in the eyelid to treat blepharospasms, and in muscles elsewhere in the body, such as the arm or leg.

Botulinum toxin types A and B are available and effective in treating focal or segmental dystonia's. Botulinum toxin has seven forms (serotypes): A, B, C, D, E, F, and G.

Botulinum toxin injections are not a cure, but they usually ease symptoms in the injected muscle in seven to 10 days. Patients usually receive maximum benefit one to two weeks after the injections. The effects can last several months, and the treatments can be repeated, often indefinitely.

A very fine needle is used for the one to three injections that are normally given per muscle. Discomfort from the injections, if any, is usually minor and temporary. Sometimes the needle is instated with the assistance of EMG to correctly locate the muscle.

Because symptoms vary during the course of dystonia, the treatment's effectiveness and duration vary from patient to patient. Subsequent injections may produce results that are less dramatic than the first, and doses may have to be adjusted. Identifying and injecting the affected muscle is not always easy.

In rare cases, a patient can develop antibodies to the botulinum toxin proteins, rendering the treatment ineffective.

Botulinum toxin treatments should not be used by pregnant or nursing women or by people taking certain medications. Side effects to the treatment include a temporary muscle weakness and discomfort at the injection site.

# **EEG-fMRI**

EEG-fMRI (short for EEG-correlated/fMRI/ or electroencephalography-correlated functional magnetic resonance imaging) is a multimodal neuroimaging technique whereby EEG and fMRI data are recorded continuously and synchronously for the study of electrical brain activity in correlation with hemodynamic changes in brain during the electrical activity, be it normal function or associated with disorders.

## **Principle**

Scalp EEG reflects the brain's electrical activity, and in particular post-synaptic potentials (see Inhibitory postsynaptic current and excitatory postsynaptic potential) in the cerebral cortex, whereas fMRI is capable of detecting hemodynamic changes throughout the brain through the BOLD effect. EEG-fMRI therefore allows measuring both neuronal and haemodynamic activity which comprise two important components of the neurovascular coupling mechanism.

## **Methodology**

The simultaneous acquisition of EEG and fMRI data of sufficient quality requires solutions to problems linked to potential health risks (due to currents induced by the MR image forming process in the circuits created by the subject and EEG recording system) and EEG and fMRI data quality. There are two degrees of integration of the data - acquisition, reflecting technical limitations associated with the interference between the EEG and MR instruments

These are interleaved acquisitions, in which each acquisition modality is interrupted in turn (periodically) to allow data of adequate quality to be recorded by the other modality, continuous acquisitions, in which both modalities are able to record data of adequate quality continuously. The latter can be achieved using real-time or post processing EEG artifact reduction software. EEG was first recorded in an MR environment around 1993. Several groups have found independent means to solve the problems of mutual contamination of the EEG and fMRI signals. The first continuous EEG-fMRI experiment was performed in 1999 using a hardware-based approach. A predominantly software-based method was implemented shortly thereafter. An addition to EEG-fMRI set up is the simultaneous and synchronized video recording without affecting the EEG and fMRI data quality for the most part, the combined EEG-fMRI data collection is now treated as a solved problem, and commercial devices are available from major manufacturers (e.g., Electrical Geodesics, Inc.), but issues remain. There are significant residual artifacts in the EEG that occur with each heartbeat. The traces in the EEG that record this are often referred to as a, "Ballistocardiogram (BCG)," because of their presumed origin in the motion of the EEG leads in the magnetic field that occurs with each heartbeat. In practice, the causes of this artifact are not well proven and may be the results of factors such as induced electrical fields with the movement of blood, etc.

## Applications

In principle, the technique combines the EEG's well documented ability to characterize certain brain states with high temporal resolution and to reveal pathological patterns, with fMRI's (more recently discovered and less well understood) ability to image blood dynamics through the entire brain with high spatial resolution. Up to now, EEG-fMRI has been mainly seen as an fMRI technique in which the synchronously acquired EEG is used to characterize brain activity ('brain state') across time allowing to map (through statistical parametric mapping, for example) the associated haemodynamic changes.

The initial motivation for EEG-fMRI was in the field of research into epilepsy, and in particular the study of inter-ictal epileptiform discharges (IED, or inter-ictal spikes), and their generators, and of seizures. IEDs are unpredictable and subclinical events in patients with epilepsy that can only be observed using EEG (or MEG). Therefore recording EEG during fMRI acquisition allows studying their haemodynamic correlates. The method can reveal haemodynamic changes linked to IED and seizures, and has proven a powerful scientific tool. The simultaneous and synchronized video recording identifies clinical seizure activity along with electrophysiological activity on EEG, which helps to investigate, correlated hemodynamic changes in brain during seizures.

The clinical value of these findings is the subject of ongoing investigations. Outside the field of epilepsy, EEG-fMRI has been used to study event-related (triggered by external stimuli) brain responses and provided important new insights into baseline brain activity, scoring resting,, wakefulness and sleep.

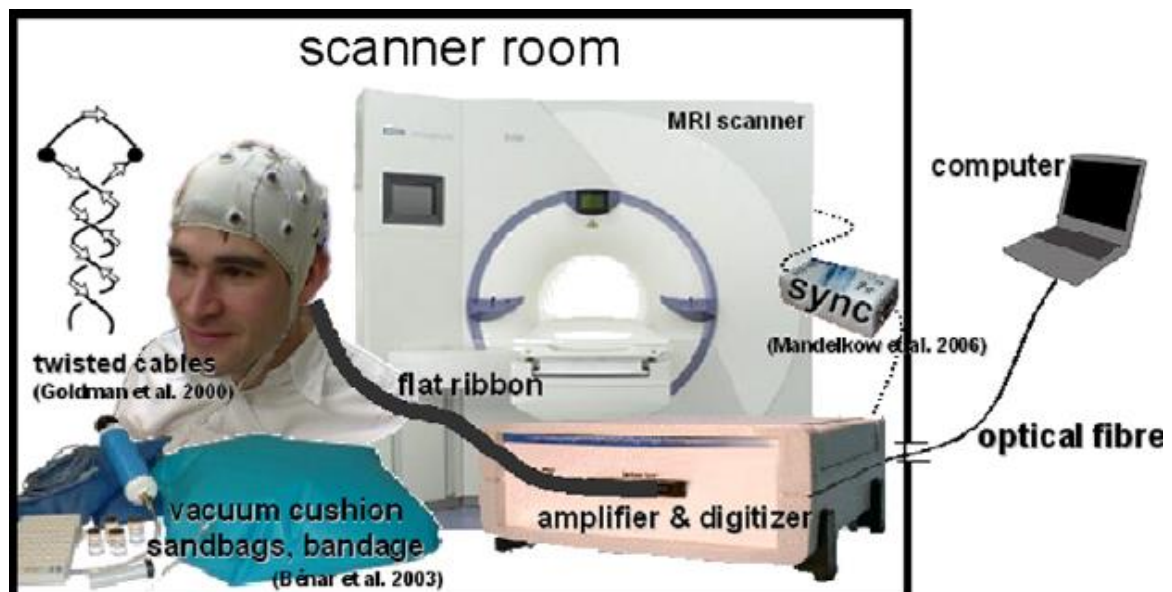

## **Technologists' role in patient safety**

It is important to understand that there is a potential hazard during the performance of an electrophysiological procedure. The electricity can kill a patient if the equipment is not properly maintained or grounded and if adequate precautions are not taken.

The following precautions are to be taken for electrical safety while doing electrophysiological procedures.

- > The power receptacle should have three holes.
- > Unnecessary electrical equipment should be kept away from the lab.
- > Whenever new equipment is installed, it should be thoroughly checked for safety.
- ) Use wooden examination table, avoid a metal table.
- > The patient should not make any contact with a metal object, grounded or ungrounded and any part of the equipment.
- > Never connect a second power line operated apparatus to the patient.

Any deliberately grounding the patient, we subject the patient to the risk of electrical shock into contact with a live voltage or with a current carrying wire. So ensure proper grounding for both the machine and the patient. When an electrical device already connected has a ground of its own on the patient, do not attach an EEG ground to the patient but use the already existing ground instead. Ground loop causes Current to flow through the patient's body. If this results in unacceptable high levels of 60/ELI Hz artifacts, remove the existing ground lead and replace it with the standard EEG electrode placement usually the center of the patient's forehead.

While doing nerve conduction studies and EMG place the ground electrode over the testing limb.



# LOG BOOK

# **ELECTROENCEPHALOGRAPHY**

## **EEG**

Sl No	Name	Age/Sex	Hosp No	Diagnosis
1	Sreenath S S	10/M	412858	BRE
2	Ahammed Kasim M	12/M	380954	CPS left temporal
3	Sarith Santhosh	17/M	409043	PME
4	Neelakandan	65/M	376366	Left MCA stroke
5	Govind kurup	12/M	341507	BOE in Remission
6	Rudhra P	8/F	413309	LRE of Childhood
7	Smrithi S	16/F	328345	PGE
8	Anugraha A	9/F	406334	Autistic spectrum disorder
9	Manikandan N	40/M	412981	Syncope vs Seizure
10	Soorya Gayathri V S	15/F	278818	BLRE
11	Nirupama S	6 <sub>month</sub> /F	413187	GEFS+
12	Amal S Wilsent	7/M	410142	JAE
13	Sundar Ganesh V	8/M	348186	FLE
14	Aneesh K Nair	23/M	413078	Tubercular Sclerosis
15	Subash S S	15/F	334327	Cryptogenic Occipital lobe epilepsy
16	Irene Thankachen	2/F	391525	Dravet Syndrome
17	Kannan K K	34/M	366730	CPS-Left MTS
18	Daksh K	4/M	412915	Static encephalopathy
19	Ahmed Hammed	3/M	413056	Probable NCL
20	Liya Saji	13/F	246433	IPOE/IGE
21	Devika AR	12/F	357754	Temporal lobe Epilepsy
22	Anshil	6/F	322731	Dravet Syndrome
23	Bhairan R.P	3 <sub>month</sub> /F	407427	VOGM
24	Aryanath B	2/M	399093	West Syndrome

SI No	Name	Age/Sex	Hosp No	Diagnosis
25	Muhammed Bilal H	11/M	293004	Atypical BRE
26	Chitra S	45/F	412735	JME
27	Bercilin S J	3/F	410436	NMDA vs ADEM
28	Aswana	10/F	310110	LKS
29	Mahadevan	26/M	344402	Doose Syndrome
30	Ummukulsu KK	50/F	412502	CJD
31	Moulik Mahesh	6/M	412251	GDD with ADHD
32	Sareena	25/F	292213	Right parietal AVM
33	Maria Albert	20/F	188433	LKS in Remission
34	Gowrykutty Amma	72/F	407279	Neuroleptic malignant syndrome
35	Nowfa Rofina JM	13/F	40000	PKD vs PNES
36	Kelvin Gregory	4/M	391626	Hypothalamic Hamertoma
37	Jithumon	18/M	412448	CAE
38	Adharv M	10/M	407377	BECTS
39	Hamna A Ullas	4/F	409014	LRE-Spastic cerebral palsy
40	Ganesh B	5/m	383595	Jeavons syndrome
41	Dhruv J	1/M	367720	HIE
42	Gireesh PK	32/M	358730	Frontal lobe epilepsy
43	Raja N	11/M	360989	West Syndrome
44	Aysha S	11/F	394030	Recurrent ADEM

SI No	Name	Age/Sex	Hosp No	Diagnosis
45	George Varghese	62/M	398263	CNS Lymphoma
46	Akhil S	16/M	348520	Tassinari Syndrome
47	Bijumon T	36/M	410973	NMO spectrum disorder
48	Najla P	14/F	411509	FIRES
49	Anand R	22/M	313374	Reflex Eating Epilepsy
50	Mournami Manna	36/F	337459	RCVS with SZ
51	Priyanka Karmakal	17/F	405986	Moya moya disease
52	Jerin J	22/M	350155	NFLE
53	Vishnu SA	24/M	385571	NCSE
54	Saramma Mathew	73/F	403530	TIA
55	Sree Krishna M	14/M	403785	PNES
56	Akshara M	13/F	405912	NMDA encephalitis
57	Sangeetha P	20/F	404513	HIE
58	Raghavan J	65/M	406708	Brain Death EEG in STICU
59	Aysha M	5/F	405981	Retts Syndrome
60	Arif Khan	11/M	318514	Tassinari Syndrome
61	Vinayak H	11/M	396901	Phonological Disorder
62	Visali G	2/F	408280	HIE
63	Mercy Jose	56/F	408340	Metabolic encephalopathy
64	Darshith	4/M	411426	Henoch-Schonlein purpura (HSP)

SI No	Name	Age/Sex	Hosp No	Diagnosis
65	Noble T Jomon	7/M	359984	BOE
66	Neha J Iyer	11/F	358207	Atypical BRE of Childhood
67	Bhuvaneswari	11/F	381861	Lissencephaly band heterotopia
68	Jubal Joesph	6/M	390947	Auto immune encephalitis
69	Vishnu K.N	16/M	409122	Migralsepsy
70	Noufal K.I	24/M	421712	Mitochondrial cytopathy
71	Prabhav K.J	4/M	408808	West syndrome
72	Nagarajan S	62/M	414673	CJD
73	Vijesh R	13/M	378301	Jeavons Syndrome
74	Noorjahan	17/F	373263	Rasmussen's encephalitis
75	Shanavas S	36/M	383753	CNS vasculitis
76	Parameswarn Nair	71/M	415441	SPS
77	Sreeraj Ramesh	14/M	415486	GDD
78	Nikhil Mathew	15/M	414835	BOE vs IPOE
79	Mohammed Anaz	9/M	413865	ADHD
80	Aswani Biju	10/F	416734	PGE vs SGE
81	Liya Biju	6/M	415235	Panayiotopoulos syndrome
82	Aiswarya	20/F	331401	Photosensitive epilepsy
83	Jhonson M	35/M	413850	Post encephalitic sequelae

SI No	Name	Age/Sex	Hosp No	Diagnosis
84	Immanuel mathew	3/M	408796	West syndrome→LGS syndrome
85	Shalin manu S	15/M	306800	IPOE
86	Adharv M	11/M	407377	BECT
87	Mohammed Shanof	10/M	357726	HHE Syndrome
88	Anil kumar G	35/M	397509	Myofacial pain syndrome
89	Jinesh Kumar	37/M	211713	Eating epilepsy
90	Kunhu Muhammed	64/M	384990	R/o CJD
91	Radhakrishnan Nair	75/M	420889	Lymphocytic hypophysitis
92	Sivaprasad PR	11/M	404077	NFLE
93	Raj G	32/M	421682	PRES
94	Shameena	7/F	385388	Absence Epilepsy
95	Arya Krishnan R	17/F	418721	Jeavons Syndrome(eyelid myoclonus)
96	Vainavin Aneesh	9 <sub>month</sub> /M	419069	Benign infantile convulsions
97	Fathimath Faheema	5/F	415427	Rett's Syndrome
98	Sarath K	25/M	343471	SSPE
99	Mohammed Burhan	10/M	272789	Anterior opercular syndrome(Foix-Chavany-Marie syndrome)
100	Bavadharani V	13/F	407033	Moya moya disease

# **VIDEO EEG**

No	Name	Age/Sex	Hos. No	Diagnosis
1	Saranya S	5/F	420032	Tassinari Syndrome(Eyelid myoclonia with absence)
2	Karthick Gowtham	19/M	420833	Status epilepticus
3	Hisan N	16/M	308826	Cps ET Right inferior frontal
4	Theresa Agnus	2/F	404825	Symptomatic West syndrome
5	Shifa Fathima N	13/F	367094	Typical FLE
6	Aniruddha Sharma	22/M	422226	Symptomatic OLE
7	Alvisha vipulbhai	10/F	422269	Down's syndrome
8	Anju Prasad	14/F	357452	LKS
9	Viswa Rajnikant G	3/F	422248	GEFS+
10	Malavika Vinod	10/F	345630	Atonic BLRE
11.	Hafeefa B K	21/F	422263	CPS temporal plus vs Temporal neocortical
12	Anshika S	7 <sub>month</sub> /F	422177	West syndrome
13	Ansiya Haris	8/F	416395	Autoimmune encephalitis
14	Neo Jerom	6/M	421854	NCSE/FLE
15	Sindhu G	24/F	421123	IGE
16	Fahmida K	21/F	417161	CPS ET- Right MTS
17	Shradha mary jobin	4/F	421853	Dravet syndrome
18	Dhanupriya Sopan	20/F	422102	PGE vs SGE
19	Adepu archana	24/F	349038	CPS-Left T-P-O

No	Name	Age/Sex	Hos. No	Diagnosis
20	Darsana R.S	11/F	421851	NFLE
21	Saketh M V	11/M	833430	Atonic BLRE
22	Anju Prasad	11/F	357452	LKS
23	Diana Rose	11/F	410001	PNES
24	Harini Kannan	8/F	422081	LKS
25	Amal Biju	16/M	421861	Right TLE
26	Mohammed Aman Z	15/M	415480	Cyclic vomiting syndrome
27	Anay Trivedi	6/M	421160	Startle epilepsy
28	Alsaha Kunnath	7/F	421381	Rasmussen's encephalitis
29	Jiya Jasmin M	8/F	420093	CAE
30	Sabith S	5/M	396611	ADNFLE
31	Rajila S	38/F	9108522	LRE
32	Meenakshi Mishra	31/F	421444	NMDA-R Encephalitis
33	Raj Bhavesh Bhai	6/M	420790	Static encephalopathy
34	Milindkhaitan	30/M	410853	JME
35	Suryansh Sharma	12/M	396952	Tassinari Syndrome
36	Isha Garg	25/F	410847	Visual Sensitive Epilepsy
37	Amalika	10 <sub>months</sub> /F	421396	Symptomatic LRE
38	Sreesanth S	6/M	408632	Atypical BRE
39	Apoorvaa S Nair	15/F	383289	Eating Epilepsy
40	Rafa Fathima MP	2/F	411268	Mitochondrial Cytopathy

No	Name	Age/Sex	Hos. No	Diagnosis
41	Subham R Bhindhi	3/M	394131	FIRES
42	Ashmit Ghosh	10/M	411136	Symptomatic LGS
43	Fenil M	10/M	411217	Eyelid Myoclonus
44	Raj Haribhhau Patil	14/M	411607	IGE-JAE
45	Piyush B Vavalia	27/M	411583	Psychosis with PNES
46	Vaibhav K	10/M	411643	BLRE
47	Mohammed Shibhili	15/M	406788	Frontal Absence(JAE)
48	Laksmi Deshmukh	10/F	386349	Reflex Epilepsy
49	Dawn Sabu	9/M	373944	Symptomatic LRE
50	Vani S Sivan	11/F	369380	Myoclonic seizures
51	Daksh. A.A	1/M	382924	Jeevan syndrome
52	Sandra Sunil F	14/F	325912	CPS ET Right SMA
53	Raju P Cherian	39/M	409140	Eating epilepsy
54	Manthan Girish Bhai	17/M	412258	HIE
55	Charulekha C	7/M	412275	Idiopathic autism disorder
56	Ayush Kunwar	14/M	369164	Bilateral PHR gliosis
57	Haroon Hameed Salim	6/M	413055	PME
58	Naba Nita Pal	24/F	412270	CPS-Pseudo temporal
59	Leo Fedrick V	4/M	413205	SSPE(-ve Myoclonus)
60	Mansi Aup	13/F	413674	Left OLE
61	Swetha Selvamany	5/F	350492	Dravet Syndrome
62	Shilpa K.O	18/F	324532	MELAS

No	Name	Age/Sex	Hos. No	Diagnosis
63	Eva Thomas	4/F	405258	Doose Syndrome
64	Gayathri Venugopal	15/F	404837	Left SMA focal SZs
65	Suhavi Kaur Bhati	6/F	390485	Rasmussen's encephalitis
66	Khusal Rajendra	14/M	367705	NFLE
67	Essakkivel T	11/M	404815	CPS ET-superior frontal gyrus
68	Jayasree	30/F	350132	CPS-Temporal plus
70	Rahul Kaurav	18/M	381611	CPS-ET
71	Mohammed Risaladar T.S	14/M	380778	Post encephalitis sequelae
72	Hiranmaya Lal	41/M	316690	Cryptogenic west syndrome
73	Nirmal.S	13/M	381163	Pseudotemporal v/s temporal
74	Jay Rajunayyer	15/M	381901	Reflex eating epilepsy
75	Akshay N Borkar	17/M	390712	PME
76	Rudheer Sree Behra	10/M	326065	Mineralising and Micro angiopathy
77	Sabika Banu	6/F	407943	Gelastc SZs (Hypothalamic hamertoma)
78	Haasan.M.D	6/M	392431	Atypical BLRE v/s Symptomatic LRE
79	Sumithra S	20/F	401034	CPS ET- Right Occipital Gliosis
80	Nikhil Singh	13/M	409190	Post encephalitic Sequelae

No	Name	Age/Sex	Hos. No	Diagnosis
81	Gokul Krishna S	4/M	394775	Childhood IGE
82	Dishita Yadav	6/F	344728	Static encephalopathy
83	Aadidev A	2/M	373212	West syndrome
84	Srijit Mazumdar	6/M	409747	CPS-ET/FLE
85	Siddhi Patidar	6/M	409960	Autism Spectrum Disorder
86	Vansh Vishal Parmar	2/M	409845	Myoclonic epilepsy
87	Linita P S	12/F	406137	Right frontal DNET
88	Allen David	6/M	318911	Epileptic encephalopathy
89	Jolly Joseph	38/F	9904697	IGE vs FLE
90	Vaishnavi R	11/F	408592	IPOE(eyelid myoclonus)
91	Janhavi Soni	2/F	407787	Hemimegalencephaly (HME)
92	Sandra Syrus	13/F	405810	Temporal Neocortical Epilepsy
93	Rugmini Amma O	73/F	405018	Limbic encephalitis
94	Madhumitha V	17/F	382388	PME
95	Mithra R	7 <sub>month</sub> /F	406973	NCL (Neuronal ceroid lipofuscinosis)
96	Pooja Sharma	17/F	363392	Rasmussen's encephalitis
97	Thanvi L	12/F	405266	Electrical status epilepticus
98	Shahna S	17/F	358170	MELAS
99	Seena Aji	36/F	409320	ADCME
100	Sagnik Sarkar	5/M	409174	Panayiotopoulos syndrome

## INVASIVE MONITORING

No	Name	Age/Sex	Hos. No	Diagnosis
1	Shabnam Answer	18/F	369146	Bilateral HC depth electrode
2	Sagar Sachdeva	21/M	378777	Temporal Grid and Frontal strip electrode
3	Manish Shantharam	41/M	395946	Temporal Grid and strip electrode
4	Jagadish Prasad	45/M	383167	Left MTS, Left occipital Gliosis(Grid&Strip Electrodes)
5	Seby P mathew	42/M	357965	Bilateral HC depth electrode
6	Fathima R	14/F	249059	Left frontal strips
7	Sagar Tyagi	12/M	379187	Left frontal grid
8	Ibrahim salim	19/M	354459	Occipital Grid&Strip electrodes
9	Anju Joshy	15/F	378475	Right CP 48Contact Grid
10	Geetha Ravi	37/F	351013	Bilateral HC Depth and Bitemporal strips

## ELECTROCORTICOGRAPHY

No	Name	Age/Sex	Hos. No	Diagnosis
1	Seby P mathew	42/M	357965	Bilateral depth electrode placement
2	Ram Shukla	11/M	391021	Right occipital lesionectomy
3	Surbhi vimal	24/M	299941	Right frontal and decompression
4	Tista Manna	12/F	395512	Right ATL+AH
5	Dikshit M.K	12/M	398843	Left parieto-occipital lobectomy
6	Sushil oli	20/ M	382424	Left temporal grid placement
7	Naina Joseph	14/F	362589	Right frontal lesionectomy
8	Saukat SK	22/ M	356113	Right frontal FCD
9	Hariharan K	10/ M	3299886	Left Occipital lobectomy
10	Geetha Ravi	37/F	351013	Bilateral HC Depth and Bitemporal strip electrode placement
11	Yasar C	26/ M	351010	Right Temporo-parieto resection
12	Nishant Pramod	15/M	406865	Right frontal craniotomy and decompression
13	Komal Goyal	3/M	401148	Left frontal lobectomy
14	Iqra Hussain	20/F	410033	Left ATL+AH
15	Amjith Ramesh	14/M	388631	Right multilobectomy
16	Asish Verma	19/ M	348179	Perisylvian lesionctomy
17	Rudrani Chakraborty	9/F	399810	Left frontal FCD
18	Manoj V	42/M	319479	Left ATL+AH
19	Jagadish Prasad	45/ M	383167	Orbto frontal grid placement
20	Daiwik Babu	3/M	390232	Left posterior quadrantectomy

# **POLYSOMNOGRAPHY**

## PSG

Sl.No	Patient Name	Age/Sex	Hosp.no	Diagnosis
1	Megha M	16/F	413861	Parasomnia
2	Vijayakumar K	62/M	414436	OSA(T2 DM,Snoring)
3	Devaki Nandanam	73/M	9107456	EDs, Moderate OSA
4	Joseph P M	64/M	355650	Somatoform disorder
5	Lissamol Jijo	10/F	415823	Narcolepsy+cataplexy
6	Sukumaran F	63/M	418243	Moderate OSA, HTN
7	Mohammed Haneefa	46/M	415374	CAD,HTN Moder. OSA
8	Mohanan Nair	63/M	415678	PVAD,Diabetic Neuropathy, ? OSA
9	Sreedharan R	68/M	415153	Dyslipdima, HTN ,OSA
10	Praveen NB	37/M	363994	Papillary ca thyroid
11	Dr.Ram Krishnan R	62/M	417323	Asthma, ?OSA
12	Nissarudeen E	45/M	413862	Narcolepsy
13	Abdul Latheef A	63/F	415155	EDs + Snoring
14	Merry Varghese	60/F	416527	Hypothyroidism, ?OSA
15	Boopathi D	29/M	414201	LV dysfunction. To r/o OSA
16	Sreedhara R	68/M	415153	OSA/HTN
17	Ajayakumar	53/F	414991	Dilated cardiomyopathy
18	Prasad V	54/M	414379	Lymphoma thyroid
19	Geetha devi S	46/F	376051	ACHD, Dyspnea
20	Chandran O.K	70/M	402324	OSA/Alzheimer's Disease

### Continuous Positive Airway Pressure Titration (CPAP) studies

Sl.No	Patient Name	Age/Sex	Hosp.no	Diagnosis
1	Honeylal M.S	56/M	415154	Severe OSA, T2 DM
2	Sanila N K	45/F	404943	Moderate OSA ,(snoring+choking in night)
3	Cedric George	48/M	335963	Moderate OSA, Parkinsons disease
4	Prasad V	54/M	414379	Moderate OSA(Snoring+EDs)
5	Thomas mamman	62/M	372991	OSA MG, , DM, Dyslipdemia
6	Chandrashekar	71/M	370669	Severe OSA(HTN,CAD)
7	Sreedharan R	68/M	415153	Severe OSA (CAD,HTN,Hypothyroidism,dyslipdima)
8	Shahul Hameed	63/F	418448	T2 DM, OSA
9	George Vargheese M	67/M	412053	Severe OSA
10	Dr.Kaveri P	53/F	379213	OSA

## **MULTIPLE SLEEP LATENCY TEST**

Sl.No	Patient Name	Age/Sex	Hosp.No	Diagnosis
1	Sindhu P.N	41/F	297441	EDs, mono symptomatic narcolepsy
2	Allen Sam Biju	14/F	416704	Narcolepsy
3	Lissamol Jijo	10/F	415823	Narcolepsy/EDs
4	Adith Jayaprasad	16/M	400622	Narcolepsy+cataplexy
5	Nisamol R	24/F	412059	Narcolepsy
6	Jessy Sebastian	35/F	366461	EDs, To r/o Narcolepsy
7	Saji Murali	41/M	392156	Idiopathic hypersomnolence
8	Aiswarya Satheesh	14/F	406294	Narcolepsy, Hypersomnia
9	Venugopalan K S	57/M	373393	EDS
10	Prahaladan	59/M	366541	Periodic hypersomnolence

**Nerve Conduction Studies (NCS)  
&  
Electromyography(EMG)**

Sl.No	Patient Name	Age/Sex	Hosp.No	Diagnosis
1.	Ushakumari	51/F	254557	Bilateral CTS
2	Ambika N	52/F	374141	Upper trunk plexopathy
3	Badarudeen A	37/M	406957	Lumbo-sacral plexopathy
4	Umaiba Beevi M	57/F	409131	GBS
5	Ayyappan Pillai. O	70/M	303135	Radiculopathy vs AHCD
6	John K	70/M	257042	Diabetic polyneuropathy
7	Sindhu S	48/F	409297	Left Sciatic neuropathy
8	Suresh.S	45/M	391516	Diabetic neuropathy
9	Sindhu.M	28/F	388071	Right C7 plexopathy
10	Mathew PJ	61/M	394285	Radiculopathy vs Plexopathy
11	Mallika KP	55/F	408536	Motor neuron disease
12	Akash P	19/M	398589	Hirayama Disease
13	Omana .O	70/F	404751	Late onset leukodystrophy
14	Jayalekshmi Ammal P	71/F	314394	Large Fiber neuropathy
15	Thankamma C N	61/F	405194	Left S1-Radiculopathy
16	Robin George Thomas	30/M	409987	GBS
17	Subramanian M	16/M	204936	HMSN-I
18	Sarala B	60/F	337159	Meralgia Parasthetica vs L5-S1 radiculopathy
19	Amal Alex Prasad	13/M	409503	Mucular dystrophy
20	Fousiya A.P	33/F	410031	Stiff persons syndrome

Sl.No	Patient Name	Age/Sex	Hosp.No	Diagnosis
21	Krishna pillai Chandran	58/M	409908	Cervical spondolysis
22	Latha M	60/F	39523	Right cervical radiculopathy
23	Minu pathrose	32/F	409261	Small fiber neuropathy
24	Sarojini Amma	78/F	409635	Mononeuritis multiplex
25	Jayasree S	56/F	409449	Type 2 Diabetes mellitus
26	Sooraj S	8/M	408703	Duchenne muscular dystrophy
27	Sudeer P	36/M	414309	Thoracic Outlet syndrome
28	Muhammed Hamdan	3/M	414409	Right Brachial plexopathy
29	Raja mani .N	67/M	415196	MND
30	Sivasankaran Nair K	73/M	413821	L5-Radiculopathy
31	Akshai Krishna	15/M	194092	Lumbosacral Plexopathy
32	Shine Salam	34/M	412408	Peroneal neuropathy
33	Sumesh	25/M	416396	Cauda equina
34	Tony mathew	45/M	378107	Large fiber neuropathy
35	Edison E	49/M	410707	Meralgia parasthetica
36	Ritwik Chakrabarthy	35/M	416343	C6-C7 PIVD
37	Aparna Damodharan	5/F	415205	Leuko dystrophy
38	Al- Ameen M	34/M	413395	Right LMN facial palsy
39	Kurian P.K	44/M	415467	Cervical PIVD
40	Sanjay Vaidan	18/M	416315	AIDP
41	Viswanathan	58/M	333021	Cervical radiculopathy

Sl.No	Patient Name	Age/Sex	Hosp.No	Diagnosis
42	Vimala Soman	49/F	394863	Tarsal Tunnel Syndrome
43	Asok kumar C	58/M	416201	Mononeuritis multiplex
44	Suresh N P	40/M	416229	Anterior horn cell disease
45	Aiswarya	33/F	415032	Right CTS
46	Tito tom	16/M	415343	Hirayama Disease
47	Sanil A.V	9/M	413236	CTEV/Hereditary neuropathy
48	Rajasekhar B	30/M	414812	Atypical MND
49	Roy P George	60/M	372179	Left Bells Palsy
50	Sasikala A	57/M	277235	CIDP
51	Josephina cilta	47/F	415599	ALS
52	Sharon K S	13/M	391901	HMSN
53	Raji V.R(Dr.)	26/F	413061	LGMD
54	Saida V	16/F	248024	HMSN- III
55	Krishna kutti pillai	60/M	415771	Left Brachial Plexopathy
56	Santha Devi N	72/F	413426	Right L5 Radiculopathy
57	Sajith S	37/M	415907	AMSAN
58	Muthu Haripriya	4/F	381742	SMA vs Congenital Myopathy
59	Shibu Jhonson	37/M	414411	Bibrachial amyotrophy
60	Amal K.R	17/M	415970	Metabolic vs Infection polyneuropathy
61	Jauhari A.C	71/M	415161	Atypical Parkinson's

Sl.No	Patient Name	Age/Sex	Hosp.No	Diagnosis
62	Riyas Abdul Azees	37/M	415772	Hypokalemic periodic paralysis
63	Rajan V	60/M	407804	Distal sensory polyneuropathy
64	Velayudhan Chettiar	63/M	383189	Right Sciatic neuropathy
65	Chaithanya	23/F	412847	SCA-II
66	Radha N	70/F	407772	Bulbar onset MND
67	Sindhu Kumari	40/F	219819	Trigeminal Neuralgia
68	Lalithambika	56/F	420626	S1 Radiculopathy
69	Jithuraj R	22/M	420482	Focal cervical AHCD
70	Manikantan Pillai	38/M	418857	ALS vs Post-polio
71	Babu B	27/M	418123	Focal AHCD
72	Pradeep P	29/M	418212	Myotonic Dystrophy-I
73	Sanish C.P	35/M	416747	Myotonia Congenita
74	Sreekumar	56/M	192287	Bilateral ulnar neuropathy
75	Rafeeka Beevi A	66/F	414956	Diabetic peripheral neuropathy
76	Valsala K	55/F	420823	Right LMN facial palsy
77	Usha D	54/F	394368	VIIth nerve palsy
78	Usha Kumary S	44/F	311968	CPEO vs Occular MG
79	Girija C	59/F	413967	Mononeuritis multiplex
80	Sadanandhan KK	65/M	382109	Large fiber neuropathy
81	Chellamma K	65/F	396959	Right CTS
82	Benazir I	37/M	422501	POEMs Syndrome

Sl.No	Patient Name	Age/Sex	Hosp.No	Diagnosis
83	Binu N	40/M	409066	Vascular claudication / CTEV
84	Mehraj Begum A	49/F	395406	Right cervical Schwannoma
85	Sandhya v kammath	51/F	410225	RRMS
86	Abdul Majeed	72/M	410350	GBS
87	Tressa Pereira	67/F	392025	Miller fisher syndrome
88	Subin Sabu	17/M	390194	Critical Illness Neuropathy
89	Lillykutty	47/F	372364	Thoraci outlet syndrome
90	Anirudhan G	51/M	386746	Myofacial pain syndrome
91	Tossy Y Morris	39/M	420725	Bell's palsy
92	Dr.Bhindu Varma	43/F	419616	Spinal accessory Neuropathy
93	Parameswaran Pillai	71/M	9403253	Meralgia Parasthetica
94	Sebas Salim	15/M	421955	ADEM
95	Rajalakshmi	16/F	403805	Kearns-Sayre Syndrome
96	Sathyasheelan	75/M	419779	Lumbar canal stenosis
97	Azad T	57/M	418969	LETM
98	Maneesh KK	28/M	417871	Charcot-marie-tooth Disease
99	Muhammed Kunju	68/M	415117	Critical Illness Neuropathy
100	Jayashankar	31/M	422472	Peroneal neuropathy

# **REPETITIVE NERVE STIMULATION**

Sl.No	Patient Name	Age/Sex	Hosp.No	Diagnosis
1	Ghadha U S	26/F	408291	Myasthenia gravis
2	Sivagnanam P	76/M	391582	Thymic Hyperplasia
3	Santhakumar M.R	45/M	359066	Muscular dystrophy
4	Thulaseedharan A	51/M	410173	Generalized MG
5	Selvasekaran A	50/M	390260	Ophthalmoplgia
6	Abdul majeed	72/M	410350	GBS
7	Devaki Amma	65/F	373372	Fatigable Potosis
8	Sainudheen P	51/M	409360	CPEO vs Occular MG
9	Sindhu kumarai	40/F	219819	Trigeminal Neuralgia
10	Girija C	57/F	375323	Thymoma
11	Marimuthu M	46/M	408742	Mediastinal tumour
12	Devi amma	65/M	414735	Right eye ptosis, r/o MG
13	Mohan rajan M K	59/M	414321	MND
14	Sreemaya Sajeev	11/F	415456	Occular myasthenia
15	Remya S	29/F	408004	Congenital ptosis vs Myasthenia Gravis

Sl.No	Patient Name	Age/Sex	Hosp.No	Diagnosis
16	Mohanan Nair P S	69/M	398196	Bulbar onset MG
17	Nalini J	15/F	417658	Congnital myopathy
18	Suja J	44/F	380252	Thymoma
19	Geetha Viswanathan	59/F	364227	MCTD with poly mitosis
20	Abdul latheef	78/M	8707166	Bilateral ptosis,r/o MG
21	Daisamma Y	56/F	314402	Bulbar Onset MG
22	Mariyappan C	30/M	410979	Generalized MG
23	Mariamamma Thomas	50/F	370419	Cranial Polyneuritis
24	Riya Babu	7/F	410303	Congenital MG
25	Sree Kumar S A	19/M	389376	Myotonia Congenita
26	Hussain N	49/M	415539	Ocular myasthenia
27	Mohankumar B	58/M	282830	Myathenia Crisis vs Cholinergic
28	Siju S.L	35/M	409578	Myasthenia Gravis
29	Anilet Punitha G	45/F	407954	Myasthenia Gravis with Thymoma
30	Gopalakrishnan pillai R	65/M	408072	CPEO vs Myasthenia garvis

## **BLINK REFLEX**

Sl.No	Patient Name	Age/Sex	Hosp.No	Diagnosis
1	Leela N	70/F	407712	Left bell's palsy
2	Pankaj Kumar Naik	28/M	412009	Left LMN facial palsy
3	Beena R S	41/F	410384	Myasthenia Gravis
4	Sukumaran Nair	66/M	412003	Right bell's palsy
5	Viswanathan Pillai	66/M	414809	Left hemifacial pain
6	Al-Ameen M	34/M	413395	Right LMN facial palsy
7	Lekshmi Vishnu	32/F	417647	Left trigeminal neuropathy vs Brain stem intraaxial lesion
8	Sajitha K.R	55/F	418727	Left UMN facial palsy
9	Yeshudasan K L	58/M	410441	Lower cranial nerve palsy
10	Sindu Kumari	40/F	219819	Trigeminal Neuralgia

## Single Fiber EMG (SFEMG)

Sl.No	Patient Name	Age/Sex	Hosp.No	Diagnosis
1	Siju S.L	35/M	409578	Myasthenia Gravis
2	Sainudheen P	71/M	409360	Occular MG vs CPEO
3	Thulaseedharan A	51/M	410173	Generalised Myasthenia Gravis
4	Prashanth R.P	28/M	409553	Occular myasthenia
5	Sreebha S	42/F	411346	Myasthenia Gravis
6	Aswathy P M	19/F	413870	Rt. eye ptosis, To r/o MG
7	Hussain N	49/M	415539	Occular myasthenia Gravis
8	Sandhakumar MT	58/M	415452	Myasthenia Gravis
9	Shibi J L	31/F	414805	Myasthenia Gravis
10	Santhakumari B	60/F	407488	CPEO vs MG

# **EVOKED POTENTIALS**

## VISUAL EVOKED POTENTIALS (VEP)

Sl.No	Patient Name	Age/Sex	Hosp.No	Diagnosis
1	Amanulla S	22/M	421989	Marfan syndrome with retinal detachment
2	Sankar guru	16/M	410222	PME
3	Sulaiman Kunju Azad	49/M	412958	NMO spectrum disorder
4	Riana jitendra thadani	6/F	411642	GDD,Static encephalopathy
5	Fathima Fidha	1/F	413038	West syndrome
6	Nanditha Satheesh	3/F	418363	Coffin Siris syndrome
7	Sajitha M	5/F	418262	SMA-II
8	Jeena John	22/F	418129	Myoclonus ataxia syndrome
9	Sameer M	12/M	422015	ADEM vs MS
10	Saya Joe	7/F	421957	Optic Neuritis
11	Thanshira M	21/F	421753	Multiple Sclerosis
12	Yadav V.K	3/M	408414	Hypothalamic hamartoma
13	Devulal S	36/M	418992	Third nerve palsy
14	Teena michael	30/F	418326	NMO vs MS
15	Ranjitha S Ravan	32/F	417492	Multiple sclerosis
16	Ashily A	13/F	418518	Tics + myoclonus
17	Gurusamy P	64/M	418282	Pachymeningitis
18	Sherin Raj R	18/F	416720	Rett's syndrome
19	Sarang P	17/F	404213	Bilateral Optic atropy
20	Priyadarshini P.R	10/F	410575	Tuberculoma

## BRAINSTEM EVOKED POTENTIALS (BAEP)

Sl.No	Patient Name	Age/Sex	Hosp.No	Diagnosis
1	Sreya K	2/F	395892	Epileptic encephalopathy
2	Yashni Deepak Patel	4/F	418800	GDD
3	Livina Sree V	5/F	398335	Static encephalopathy
4	Ramya	31/F	403592	Multiple Sclerosis
5	Sarith Santhoh	17/M	409043	PME Syndrome
6	Sajeesh P	37/F	399580	Mitochondrial cytopathy
7	Jamaludhhen kunju M	54/M	397224	Cranial Neuritis
8	Bhuvanedaran Nair	59/M	394364	Left 8 <sup>th</sup> nerve palsy
9	Vairamuthu S	1/M	401042	HIE
10	Precilla Ann <small>Thomas</small>	25/F	403488	SCA
11	Adwaith SS	12/M	405980	Optic atropy with hearing loss
12	Tania(Sr.)	43/F	411361	Fronto opercular granuloma
13	Mariyam L A	46/F	415778	PPMS
14	Dipan lal P	23/M	401501	Demyelination
15	Navani Raj	13/F	409286	CPEO
16	Binu John	38/M	415093	Long segmental myelitis
17	Anvar S	37/M	414430	Multiple sclerosis
18	Adya Nair	6/F	401669	NMDAR with Sequale
19	Haizel Elze Joseph	17/F	402565	RRMS
20	Asmina Rinas	14/F	416456	SSPE

## SOMATOSENSORY EVOKED POTENTIALS (SSEP)

Sl.No	Patient Name	Age/Sex	Hosp.No	Diagnosis
1	Vishnu J	18/M	420469	Propable PME
2	Vinish M	16/M	418882	Multiple sclerosis
3	Karthika R	14/F	417400	PME
4	Aromal R	21/M	416906	1° vs 2° demyelination
5	Abhay Bhagath	1/M	411667	Myoclonic ataxia
6	Mallika M	45/F	416252	DAVF
7	Bhagath S.B	5/ M	415328	Static encephalopathy
8	Vishesh Jain	10/ M	400003	Metabolic encephalopathy
9	Jibin vargheese	29/ F	397443	Mitochondrial cytopathy
10	Binzar K	35/ M	414649	CNS Demyelination
11	Vishnu Dutt S	14/ M	378829	Cerebellar Ataxia
12	Lakshitha S	8/F	413239	Myoclonic epilepsy
13	Manjusha G	17/ F	412405	Multiple sclerosis
14	Abhirama Raja	28/ M	409242	? Myelitis
15	Asiya Beevi	42/ F	406552	Focal cervical anterior horn cell disease
16	Muhammed Shafeek R	5/M	406105	Mitochondrial cytopathy
17	Radha Ganeshan	65/F	404587	NMO Spectrum disorder
18	Sunitha S	39/F	273928	RRMS
19	Krishna M S	23/ F	385352	ADEM
20	Premkumar	22/M	391341	Multifocal myoclonus

**VISUAL ACUITY  
&  
VISUAL FIELDS TESTING**

Sl.No	Patient Name	Age/Sex	Hosp.No	Diagnosis
1	Deepika	17/F	226290	Craniopharyngioma
2	Joesph A P	78/M	231206	Prolactinoma
3	Viswana V	9/F	389618	Tubercular meningitis
4	Harishma K	17/F	361272	Left frontal DNET
5	Praveen Mohan	25/M	390013	NMO Spectrum disorder
6	Ashoka kurup	46/M	390953	Right Vestibular schwannoma
7	Karthika Kumari	50/F	329319	Pituitary macro adenoma
8	Krishna MS	23/F	385352	ADEM
9	Noushad A	39/M	391157	Optic atrophy
10	Haritha MK	33/F	379480	IIH
11	Rajina J	34/F	371282	IIH with bacterial meningitis
12	Meera A	11/F	348029	Occipital gliosis
13	Arumughan R	44/M	384055	Tectal plate glioma
14	Irulayee M	28/F	392414	Cerebellopontine angle syndrome
15	Rama Devi	52/F	386278	Multiple sclerosis
16	Rajina J	34/F	371282	IIH with bacterial meningitis
17	Ashika Salim	27/F	393258	Left Optic neuritis
18	Raju P A	49/M	213590	Right parietal glioma
19	Sajini A	11/F	384494	Ocular surface disease
20	Nived S.L	9/M	367699	Suprasellar lesion

Sl.No	Patient Name	Age/Sex	Hosp.No	Diagnosis
21	Sumathyamma G	74/F	392436	Optic neuropathy
22	Anil Kumar.R	42/M	3703070	Pituitary adenoma
23	Vignwsh umar	16/M	371890	ADEM
24	Vijaya G	36/F	393326	IIH
25	Manoj Thomas	46/M	9904661	Left parietal gliosis
26	Thendral S	26/F	393935	Ophthalmic segment aneurysm
27	Shiju Raj S	28/M	389560	Left occipital AVM
28	Amina Fadiya	12/F	373726	Optic chiasmic glioma
29	Sujakumari G	58/F	394964	Sphenoid wing meningioma
30	Mohandas CC	49/M	9803210	Orbital sclerosis
31	Jasmin S	17/F	384253	Left temporal DNET
32	Prasanna	58/F	394687	ICA aneurysm
32	Prasanna	58/F	394687	ICA aneurysm
33	Kuttappan	61/M	378400	Pineal gland cyst
34	Latha	22/F	381566	Ocular meningioma
35	Vinayakan.C	36/F	328851	Pituitary adenoma
36	Aysha.K.N	63/F	372214	Meningioma
37	Subin Sabu	17/M	390194	Ischemic optic neuropathy
38	Sunil Kumar M.K	49/M	302661	Right optic nerve meningioma
39	Arya Krishna	21/F	391020	Bilateral optic atrophy

Sl.No	Patient Name	Age/Sex	Hosp.No	Diagnosis
40	Swathy Sathyan	23/F	373814	Multiple Sclerosis
41	Ranesh K	38/M	330564	RRMS
42	Suresh Kumar S	45/M	396729	Cortical sinus thrombosis
43	Arun P	16/M	395975	Central neurocytoma
44	Indulekha	40/F	398545	Olfactory groove meningioma
45	Mahaboob	43/F	373396	DAVF
46	Deepak J	21/M	399107	Right optic neuritis
47	Rohan S Kumar	12/M	400492	Chiari malformation
48	Mubeena Beevi	38/F	407132	Occipital AVM
49	Jayakumar	58/M	392938	Cortico-basal-ganglionic Degeneration
50	Dayena Thomas	10/F	35841	Neeuromyelitis
51	Akshaya Adhikay	17/F	357739	Left ATL+AH on 17/05/2013
52	Udauan P	42/M	400499	Macro adenoma
53	Lathaa Vijayan	51/F	350689	Pachy Meningitis
54	Muniya Samy K	28/M	402831	Frontal Glioma
55	Rajgopal C R	39/M	384995	Cingulate gyrus glioma
56	Saleena Beevi	37/M	299356	IIH
57	Dipankar Roj	32/M	32/M	Left ATL+AH on 28/1/2015
58	Sheri maniyam R	18/F	331731	Recurrent optic neuritis
59	Syam kumar	15/M	401039	Optic-chiasmatic lesion

Sl.No	Patient Name	Age/Sex	Hosp.No	Diagnosis
60	Mohanan.S	55/M	8705915	Pituitary adenoma
61	Kallyani R	47/F	388777	Cerebellar meningioma
62	Sreekutty S	10/F	401881	LETM
63	Sheeja M	31/F	366599	Optic neuritis
64	Poongo Thai	29/F	402983	Benign ICT
65	Thankappan C	68/M	403386	Olfactory groove meningioma
66	Mani V	17/M	401668	Left occipital AVM
67	Suresh M	14/M	403476	Bilateral PHR Gliosis
68	Pothammal	51/f	342120	Optic nerve entrapment
69	Dhayanthi.P	37/F	384741	Left vestibular Schwannoma
70	Lalitha.K.V	49/F	316069	Bilateral optic atrophy.
71	Adarsh Krishnan	26/M	297630	NMO spectrum
72	Badaruddeen	50/M	404136	Sphenoid sarcoma
73	Rohini Sugunan	51/F	404516	Tolosa-Hunt syndrome (THS)
74	Ajina MS	25/M	340333	SPMS
75	Sosamma	43/F	405067	Orbital pseudotumor
76	Abhisha JV	6/F	381530	ADEM
77	James George	46/M	404723	Pituitary macroadenoma
78	Serin Prasad	25/M	375542	Left optic neuritis
79	Alin Raj	21/M	403822	TB meningitis
80	Ambili C.G	38/F	396890	Vestibular multiple sclerosis

Sl.No	Patient Name	Age/Sex	Hosp.No	Diagnosis
81	Helen malar	42/F	400131	Colloid cyst
82	Amar Jyothy.R.K	34/M	282333	Ocular lesion
83	Safia Jasmin	11/F	263817	Optic glioma
84	Jayasree.S	41/F	365259	IIH
85	Bindhu VB	45/F	298161	Chordoma
86	Riya Hashim	26/M	407972	Left optic atropy
87	Ajitha Kumari T	42/F	408264	Multiple myeloma mets
88	Sumathi M	26/F	409101	CP angle epidermoid
89	Jayaprakash B	53/F	382435	Sarcoidosis
90	Pradeep S	38/M	396982	Pituitary apoplexy
91	Arjun V	20/M	353248	Hypothalamic optic chiasmal granuloma
92	Karthika R	14/F	4177400	PME
93	Abhinath B	4/M	415530	SEGA Subependymal Giant Cell Astrocytoma ( <i>brain tumor</i> )
94	Rani L	28/F	415109	Benign intracranial hypertension
95	Thomaskutty	49/M	414297	Thalamic glioma
96	Nusaiba P	23/F	413580	Papilledema
97	Giri VV	64/M	399916	Retinal hemorrhage
98	Reji Ashokan	30/M	331913	Pituitary adenoma
99	Lalitha M	29/F	390593	Trigeminal schwannoma
100	Godfrey Fernanfez	22/M	385959	Leber hereditary optic neuropathy (LHON)

