

301  
DNT 06

DNT

SREE CHITRA TIRUNAL INSTITUTE FOR MEDICAL SCIENCES  
&  
TECHNOLOGY,  
THIRUVANANTHAPURAM, KERALA, INDIA - 695011.



**DIPLOMA IN NEUROTECHNOLOGY**

**Work book submitted by**

**Niju Jacob,  
Dept. of Neurology,  
SCTIMST,  
Thiruvananthapuram.**

2005-2006

<b>SCTIMST</b> HOSPITAL COMPLEX LIBRARY
301
<hr/>
DNT 06

# **CONTENTS**

**The Acknowledgement**

**The Institute**

**Course details**

**Electroencephalography**

**EEG in Intensive Care Setup**

**Prolonged Video EEG Monitoring**

**Intraoperative Monitoring**

**Polysomnography**

**Visual Evoked Potentials**

**Brainstem Auditory Evoked Potentials**

**Somatosensory Evoked Potentials**

**Electromyography**

**Optometry**

## CERTIFICATE

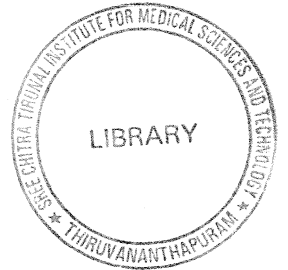

I Mr. Niju Jacob.... hereby declare that I have performed all the procedures listed/carried out the project, under report.

Signature ..... 

Name NIJU JACOB.....

Place: Thiruvananthapuram  
Date: 20/11/06

Forwarded. He has carried out the minimum requirement of procedures.

Signature..... 

Head of the Department of Neurology,  
SCTIMST, Thiruvananthapuram.

**K. Radhakrishna**,  
Professor and Head  
Department of Neurology  
Sree Chitra Tirunal Institute for  
Medical Sciences and Technology  
Trivandrum-695 011

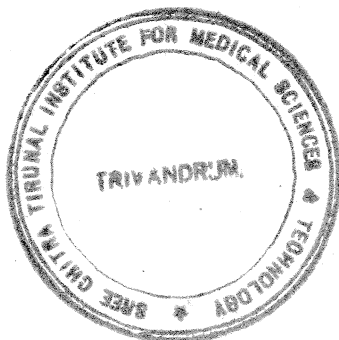

## **ACKNOWLEDGEMENT**

First and foremost I would like to thank the Head of the Department of Neurology Dr. K. Radhakrishnan and all other faculty members of the Department who guided me through the different phases of studies and encouraged and helped me in all the aspects of my training.

I thank the Director of this Institute Dr. K. Mohandas, Dean Dr. K. Radhakrishnan and Registrar Dr. A.V. George for their valuable advice, help and attention towards me.

I express my gratitude to Professor Dr.M.D.Nair and Professor Dr. C. Sarada for their inevitable advice, which helped me for the successful completion of the course. I also thank all other faculty members of the Department who helped and encouraged me in technical studies.

I extended my heartfelt thanks to all technical staff, especially Mr. Venugopal for his timely guidance and ideas that helped me to learn more. I am also grateful to all the P.G students of the Department of Neurology.

I am also thankful to all my friends who helped me during the study in the Institute and the patients who were the core medium of the study.

Last but not least I would like to acknowledge my sincere thanks to my seniors and juniors and my colleague for their co-operation in the work places and in the studies. I also thank my well wishers who helped me in all the way during the last two years.

**SREE CHITRA TIRUNAL INSTITUTE FOR MEDICAL SCIENCES  
& TECHNOLOGY (SCTIMST), THIRUVANANTHAPURAM,  
KERALA, INDIA.**

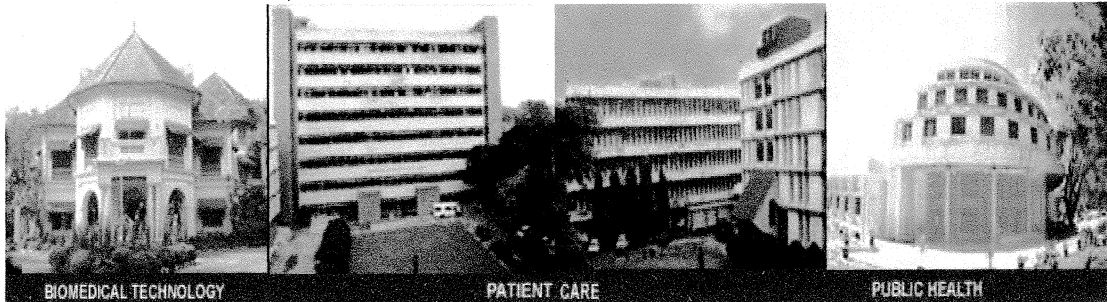

The Sree Chitra Tirunal Institute for Medical Sciences & Technology (SCTIMST), Thiruvananthapuram is an Institute of National Importance established by an Act of the Indian Parliament. It is an autonomous Institute under the administrative control of the Department of Science and Technology, Government of India.

The Institute signifies the convergence of medical sciences and technology and its mission is to enable the indigenous growth of biomedical technology, besides demonstrating high standards of patient care in medical specialties and evolving postgraduate training programs in advanced medical specialties, biomedical engineering and technology, as well as in public health.

It has a 239-bedded hospital for tertiary care of cardiovascular and neurological diseases, a biomedical technology wing with facilities for developing medical devices from a conceptual stage to commercialization, and a center of excellence for training and research in public health.

The Institute has the status of a University and offers postdoctoral, doctoral and postgraduate courses in medical specialties, public health, nursing, basic sciences and health care technology. It is a member of the Association of Indian Universities and the Association of Commonwealth Universities.

## **Diploma in NeuroTechnology**

Diploma in Neurotechnology (DNT) is a two-year academic course under the department of Neurology, Sree Chitra Tirunal Institute for Medical Sciences and Technology. During the course of study in the institute the student is imparted with both theoretical and practical knowledge with regard to the subject. The student in the Institute becomes exposed to very expensive machines of latest technology, which he/she may find difficult to find in ordinary places. Since the Institute is a tertiary care Hospital, the student gets the opportunity to study patients with varied neurological diseases.

The practical grounds where the student learn the work stands to be unmatched elsewhere in our country.

During the two- year period the student is given EEG, EMG and Video EEG posting to get trained in the specific diagnostics. In the EEG lab he gets to know about the connections, recording of EEG and activation procedures of international standards. The student also gets training in acuity testing and field charting since the Optometry Lab forms a part of the Department of Neurology. In the EMG posting the student learns the techniques for nerve conduction, eliciting evoked potentials and machine operation for assisting the consultants to perform the EMG study. The student is also trained in Video EEG lab for monitoring prolonged EEG studies like VEEG monitoring, SPECT studies, MSLT, Polysomnography etc. In the Institute the students are allowed for observing Intra operative monitoring and Electroencephalography. With all this, the presence of many doctors with most excellence brings in the confidence for the student to work under strict conditions, where patient care is given the utmost importance.

**ELECTROENCEPHALGRAM**

## **Introduction**

The electroencephalogram (EEG) is a recording of the electrical activity of the brain. The first recording was made by Hans Berger in 1929 although similar studies has been carried out in animals as early as 1870.

The waveforms recorded are thought to reflect the activity of the surface of the brain, the cortex. The activity is influenced by the electrical activity form the brain structures underneath the cortex.

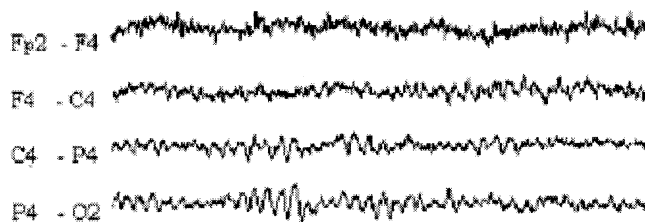

*EEG traces*

The nerve cells in the brain produce signals that are called action potentials. These action potentials move from one cell to another across a gap called the synapse. Special chemical called neurotransmitters, one will help the action potential to move to the next cell, the other will stop it moving to another nerve cell. The brain normally works hard to keep an equal amount of each of these neurotransmitters in the brain. EEG activity is quite small, measured in micro volts (mV) with the main frequencies of interest up to approximately 30 Hertz (Hz).

## **Electrodes**

Small metal discs called electrodes are placed on the scalp in special positions. The recordist who measures the head using the International 10-20 System identifies these positions. This relies on taking measurements between certain fixed points on the head. The

electrodes are then placed at points that are 10% and 20 % of these distances.

Each electrode site is labeled with a letter and a number. The letter refers to the area of the brain underlying the electrode. e.g. F – frontal lobe and T- temporal lobe. Even numbers denote the right side of the head and odd numbers the left side of the head.

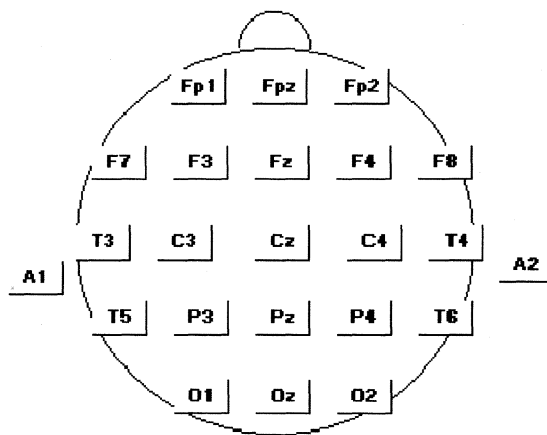

10-20 System of electrode placement

There are a great variety of electrodes that can be used. The majority are small discs of stainless steel, tin, gold or silver covered with a silver chloride coating. These normally have a lead attached. Alternative methods consist of a cap in which the electrodes are already embedded.

### **Montages**

EEG machines use a differential amplifier to produce each channel or trace of activity. Each amplifier has two inputs. An electrode is connected to each of the inputs.

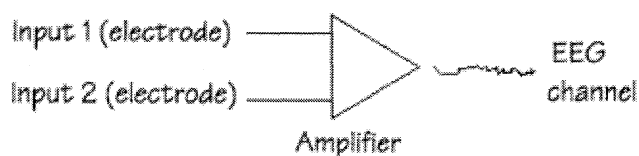

## Differential amplifier

Differential amplifiers measure the voltage difference between the two signals at each of the inputs. The resulting signal is then amplified and then displayed as a channel of EEG activity.

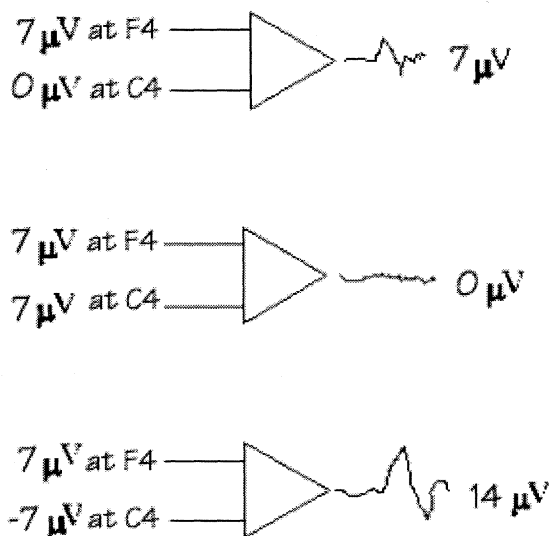

*Amplifier principles*

The manner in which the pair of electrodes are connected to each amplifier of the EEG machine is called a montage. Each montage will use one of the Three standard recording derivations, common reference, average reference or bipolar.

Common reference derivation: Each amplifier records the difference between a scalp electrode and a reference electrode. The same reference electrode is used for all channels. Electrodes frequently used as the reference electrode are A1, A2, the ear electrodes, or A1 and A2 linked together.

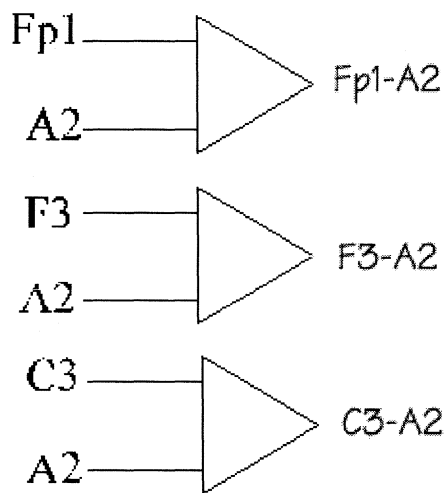

*Common reference derivation*

Average reference derivation: Activity from all the electrodes are measured summed together and averaged before being passed through a high value resistor. The resulting signal is then used as a reference electrode and connected to input 2 of each amplifier and is essentially inactive. All EEG systems will allow the user to choose which electrodes are to be included in this calculation.

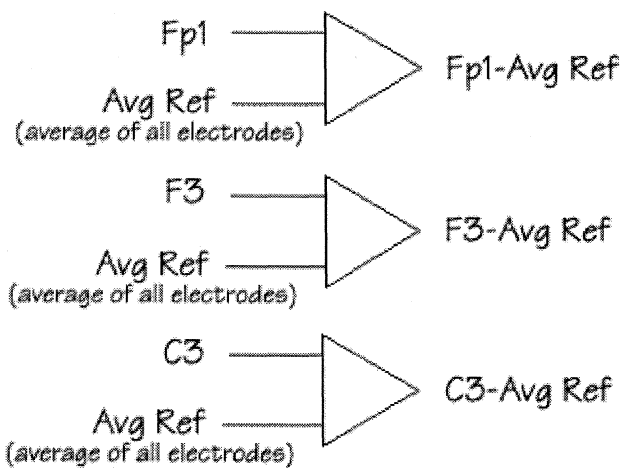

*Average reference derivation*

Bipolar derivation: These sequentially link electrodes together usually in straight lines from the front to the back of the head or transversely across the head. For example the first amplifier may have electrodes FP1 and F3 connected to it and the second amplifier F3 and C3 connected to it.

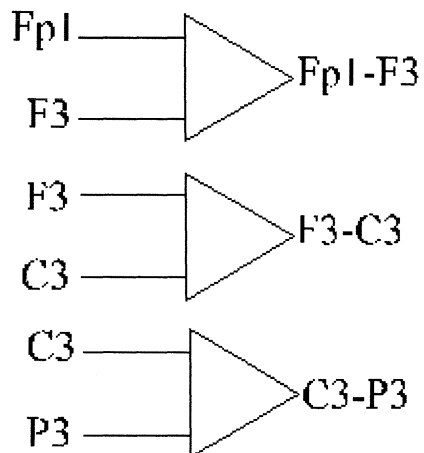

*Bipolar derivation*

### **Analogue EEG instruments**

Conventional analogue instruments consist of an amplifier, a galvanometer and a writing device. A galvanometer is a coil of wire inside a magnetic field. The output signal from the amplifier passes through the wire causing the coil to oscillate. A pen mounted on the galvanometer moves up and down each time the coil moves. The pen draws the trace onto paper moving below it.

High and low frequency filters and sensitivity controls control the amplifier output. The high and low frequency filter values will set the window within which the EEG activity is recorded. This is known as the bandwidth. The sensitivity controls the size of the activity displayed. For example a sensitivity of 10  $\mu\text{V}/\text{mm}$  means that a signal with amplitude of 100  $\mu\text{V}$  will produce a 1 cm vertical deflection.

The speed at which the paper moves on will also affect the appearance of the waveforms.

### **Digital EEG instruments**

A digital EEG system converts the waveform into a series of numerical values. This process is known as Analogue-to-Digital conversion (ADC).

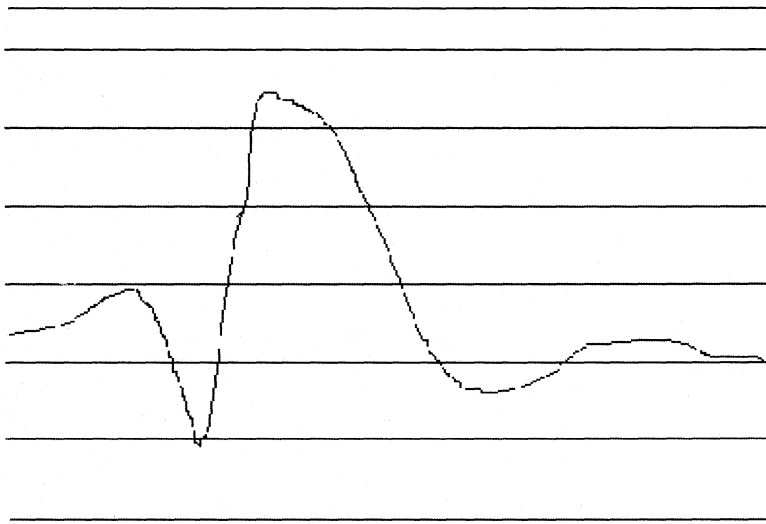

*Analogue waveform*

The values can be stored in the computer memory, manipulated and then redisplayed as waveforms on a computer screen. The rate at which the waveform data is sampled in order to convert it into a numerical format is known as the *sampling rate*.

The sampling rate is usually expressed in Hz, for example 240 Hz is 240 times per second. The minimum acceptable sampling rate is 2.5 times greater than the highest frequency of interest but most digital EEG systems will sample at 240 Hz.

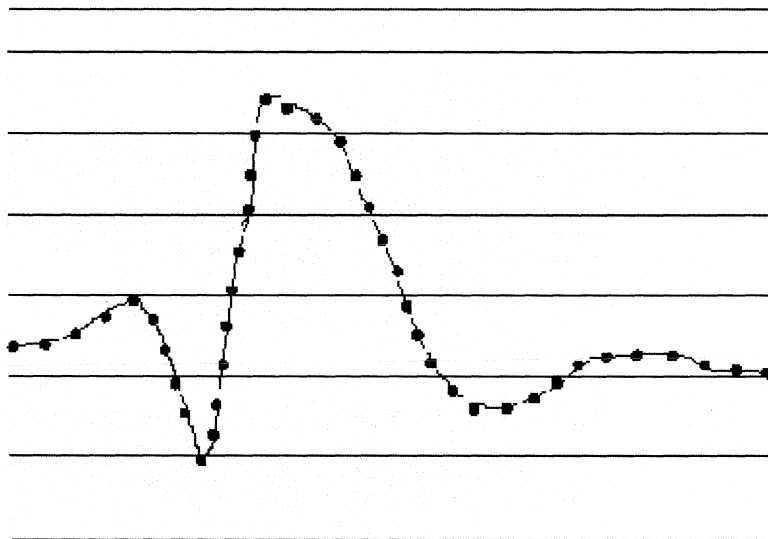

*Sampling rate of 240 Hz*

Some recordings which involve recording activity directly from the brain surface, may have activity of a higher frequency, for example 200 Hz. Therefore some digital EEG systems will have optional sampling rates of 480 Hz available.

Sampling at rates lower than this will mean that when the signal is converted back to analogue form, it will not resemble the original waveform

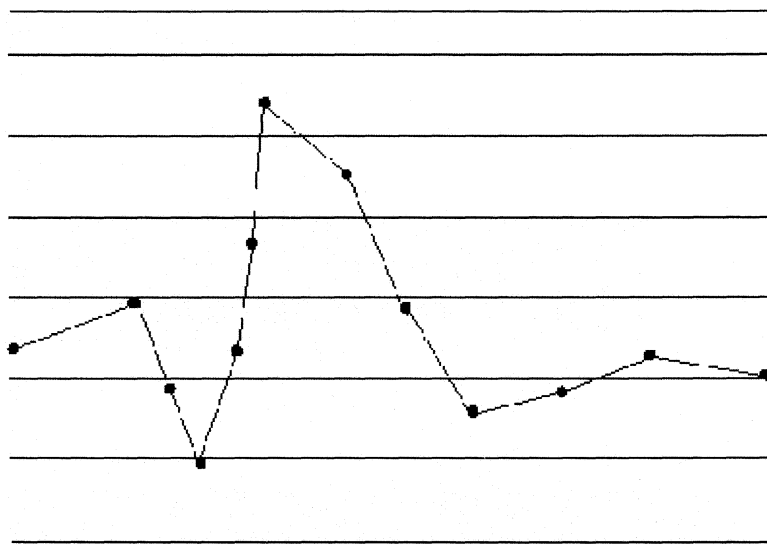

Sampling rate of 50 Hz

A second factor that affects the accuracy of the waveform is *sampling skew*. Sampling skew occurs when all channels are not sampled simultaneously. Many digital EEG systems sample channel 1 first, then sample channel 2, then channel 3 etc. The time lag between sampling of each channel is known as sampling skew. To reduce the sampling skew, some digital systems use *burst mode* sampling. This increases the speed between successive channels sampling in order to reduce the amount of sampling skew.

A third factor that affects the accuracy of digital EEG waveforms is the display. The accuracy of a monitor display depends on the number of points or pixels that are available. The number of pixels available is referred to as the screen resolution. Screen resolution is described in numbers that represent the pixels available in the horizontal and vertical axis.

A VGA display has a resolution of 640 x 480 pixels while a monitor with a Super VGA display will have a screen resolution of around 1024 x 768 pixels. A typical page of EEG contains 10 seconds of data. A

digital EEG system, sampling at rates of 240 Hz will need to display 2400 samples horizontally for each recording channel. The highest screen resolutions available today do not have enough pixels to match the number of data samples. Systems that draw every other sample or every third sample in order to match the screen resolution will have the effect of reducing the sampling rate and displaying incomplete data. An accurate digital system will draw two data samples per screen pixel. This means that all data points can be displayed and sampling rates will not be decreased.

EEG signals that have been digitized can be manipulated to change the montage 'on-line' at the time of recording or 'off-line' after the recording is completed. This 'remontaging' is accomplished by recording all EEG channels with a common reference electrode. Regardless of the montage used to display the data while it is being recorded, data is stored into the computer memory in common reference mode. This allows the data to be displayed using different montages at a later time. Since digital systems store the analogue signal as numerical values, remontaging is a simple subtraction process, which results in cancellation of the common reference.

An example is shown in the next figure. The reference electrode A1 is common to both channels on input 2. It has the identical value in each channel. Remontaging these two channels together into one new channel is by subtraction, which mathematically will cancel the value at the reference electrode. The resulting channel will therefore display the potential difference between F3 (input 1) and F4 (input 2).

$$\begin{array}{rcc}
 \text{Input 1} & & \text{Input 2} \\
 (F3 - A1) & - & (F4 - A1) \\
 & \downarrow & \\
 F3 - \cancel{A1} & - & F4 + \cancel{A1} \\
 & \downarrow & \\
 & F3 - F4 & 
 \end{array}$$

## **ARTIFACTS IN EEG**

Although EEG is designed to record cerebral activity, it also records electrical activities arising from sites other than the brain. The recorded activity that is not of cerebral origin is termed artifact and can be divided into physiologic and extra physiologic artifacts. While physiologic artifacts are generated from the patient, they arise from sources other than the brain (i.e., body). Extra physiologic artifacts arise from outside the body (i.e., equipment, environment).

### **Muscle (electromyogram) activity**

Myogenic potentials are the most common artifacts. Frontalis and temporalis muscles (e.g., clenching of jaw muscles) are common causes. Generally, the potentials generated in the muscles are of shorter duration than those generated in the brain and are identified easily on the basis of duration, morphology, and rate of firing (i.e., frequency). Particular patterns of electromyogram (EMG) artifacts can occur in some movement disorders. Essential tremor and Parkinson disease can produce rhythmic 4- to 6-Hz sinusoidal artifacts that may mimic cerebral activity.

Another disorder that can produce repetitive muscle artifacts is hemifacial spasm. The photomyoclonic response is a special type of EMG artifact that occurs during intermittent photic stimulation. Some subjects contract the frontalis and orbicularis muscles. These contractions occur approximately 50-60 milliseconds after each flash, disappear after eye opening and use of paralyzers, are located mostly frontally, and have no concomitant EEG changes.

### **Glossokinetic Artifact**

In addition to muscle activity, the tongue (like the eyeball) functions as a dipole, with the tip negative with respect to the base. In this case, the tip of the tongue is the most important part because it is more mobile. The artifact produced by the tongue has a broad potential field that drops from frontal to occipital areas, although it is less steep than that produced by eye movement artifacts. The amplitude of the potentials is greater inferiorly than in parasagittal regions; the frequency is variable but usually in the delta range and occurs synchronously when the patient says "Lah-lah-lah-lah" or "Lilt-lilt-lilt-lilt," which can be verified by the technologist. Chewing and sucking can produce similar artifacts. These commonly are observed in young

patients. However, they also can be observed in patients with dementia or those who are uncooperative.

### **Eye movements**

Eye movements are observed on all EEGs and are useful in identifying sleep stages. The eyeball acts as a dipole with a positive pole oriented anteriorly (cornea) and a negative pole oriented posteriorly (retina). When the globe rotates about its axis, it generates a large-amplitude alternate current field, which is detectable by any electrodes near the eye. The other source of artifacts comes from EMG potentials from muscles in and around the orbit.

Vertical eye movements typically are observed with blinks (i.e., Bell phenomenon). A blink causes the positive pole (i.e., cornea) to move closer to frontopolar (Fp1-Fp2) electrodes, producing symmetric downward deflections. During downward eye movement the positive pole (i.e., cornea) of the globe moves away from frontopolar electrodes, producing an upward deflection best recorded in channels 1 and 5 in the bipolar longitudinal montage.

Lateral eye movements most affect lateral frontal electrodes F7 and F8. During a left lateral eye movement, the positive pole of the globe moves toward F7 and away from F8. Using a bipolar longitudinal montage, maximum positivity in electrode F7 and maximum negativity in electrode F8 is recorded, and artifacts do not occur in channels 9 and 13 or 10 and 14. A so-called rectus lateralis may be present in electrode F7; it is observed best in the vertex reference montage. With right lateral eye movement, the opposite occurs.

### **ECG artifact**

Some individual variations in the amount and persistence of ECG artifact are related to the field of the heart potentials over the surface of the scalp. Generally, people with short and wide necks have the largest ECG artifacts on their EEGs. The voltage and apparent surface of the artifact vary from derivation to derivation and, consequently, from montage to montage. The artifact is observed best in referential montages using earlobe electrodes A1 and A2

ECG artifact is recognized easily by its rhythmicity/regularity and coincidence with the ECG tracing (each "sharp wave" equals artifact that synchronizes with each QRS complex of the ECG channel. The situation becomes difficult when cerebral abnormal activity (e.g., sharp

waves) appears intermixed with EEG artifact, and the former may be overlooked. The EEG technologist should apply electrodes routinely to record the ECG.

### **Pulse**

Pulse artifact occurs when an EEG electrode is placed over a pulsating vessel. The pulsation can cause slow waves that may simulate EEG activity. A direct relationship exists between ECG and the pulse waves. The QRS complex (i.e., electrical component of the heart contraction) happens slightly ahead of the pulse waves (200-300 millisecond delay after ECG equals QRS complex).

### **Respiration artifacts**

Respiration can produce 2 kinds of artifacts. One type is in the form of slow and rhythmic activity, synchronous with the body movements of respiration and mechanically affecting the impedance of (usually) one electrode. The other type can be slow or sharp waves that occur synchronously with inhalation or exhalation and involve those electrodes on which the patient is lying. Several commercially available devices to monitor respiration can be coupled to the EEG machine. As with the ECG, one channel can be dedicated to respiratory movements. The simplest way to monitor respiration is by the EEG technician making notations with a pencil (i.e., upward movement of the pencil for inhalations, downward return for exhalations).

### **Skin artifacts**

Biological processes and/or defects may alter impedance and cause artifacts. Sweat is a common cause. Sodium chloride and lactic acid from sweating reacting with metals of the electrodes may produce huge slow baseline sways.

Significant asymmetry also can be observed when a collection (e.g., subgaleal hematoma) is under or in the skin. In this last example, the amplitude of the background rhythm is reduced in derivations from electrodes overlying the hematoma.

Skull defects also can be the source of asymmetry. In this situation, amplitudes are greater in derivations from electrodes overlying or adjacent to skull defects.

## **Electrodes**

The most common electrode artifact is the electrode popping. Morphologically this appears as single or multiple sharp waveforms due to abrupt impedance change. It is identified easily by its characteristic appearance (i.e., abrupt vertical transient that does not modify the background activity) and its usual distribution, which is limited to a single electrode. In general, sharp transients that occur at a single electrode should be considered artifacts until proven otherwise. At other times, the impedance change is not so abrupt, and the artifact may mimic a low-voltage arrhythmic delta wave.

## **Alternating current (60/50 -Hz) artifact**

Adequate grounding on the patient has almost eliminated this type of artifact from power lines. The problem arises when the impedance of one of the active electrodes becomes significantly large between the electrodes and the ground of the amplifier. In this situation, the ground becomes an active electrode that, depending on its location, produces the 50-Hz artifact. The artifact presents at exact frequency (50 Hz, as its name indicates). A better identification can be made by increasing the paper speed (i.e. sweep time) to 50 mm/s and counting it (1 cycle per millimeter).

## **Movements in the environment**

Movement of other persons around the patient can generate artifacts, usually of capacitive or electrostatic origin. Avoid this type of artifact as much as possible. If avoidance is not possible, as in the ICU and the operating room, place proper notation on the records.

Another artifact, probably due to electrostatic changes on the drops, can be introduced by a gravity-fed intravenous infusion. Morphologically this appears as spike transient potentials at fixed intervals that coincide with drops of the infusion.

With the increasing use of automatic electric infusion pumps, a new type of artifact, infusion motor artifact (IMA), has arisen. Morphologically, IMA appears as very brief spiky transients, sometimes followed by a slow component of the same polarity. Its frequency does not relate directly to drop rate. Lininger et al have suggested that this artifact arises from electromagnetic sources.

The artifact produced by respirators varies widely in morphology and frequency. Monitoring the ventilator rate in a separate channel helps to identify this type of artifact.

Interference from high-frequency radiation from radio, TV, hospital paging systems, and other electronic devices can overload EEG amplifiers. The pens may deflect upward or downward to full excursion, and no EEG can be recorded. The cutting and/or coagulating electrode used in the operating room also generates high-voltage high-frequency signals that interfere with the recording system. The best thing to do is turn off the EEG machine while using this instrument

### **EEG Applications**

One of the major roles of EEG is as an aid to diagnose epilepsy. Abnormal patterns such as spikes, sharp waves and/or spike and wave complexes can be seen. The type of activity and the area of the brain that it is recorded from will assist the physician in prescribing the correct medication for that type of epilepsy.

Patients with epilepsy that cannot be controlled by medication will often have surgery in order to remove the damaged tissue. The EEG plays an important role in localizing this tissue. Special electrodes can be inserted through the cortex or alternatively a grid of electrodes placed directly on the surface of the cortex. These recordings, often called Long Term Monitoring for Epilepsy (LTME), can be carried out for periods ranging from 24 hours to 1 week. The EEG recorded will indicate which areas of the brain should be surgically removed.

EEG studies can also be used in patients who are deeply unconscious, to distinguish between brain death and possible reversible conditions.

Electro cerebral inactivity (ECI) or electro cerebral silence (ECS) is defined as no EEG activity over  $2 \mu V$  in amplitude when recording from electrodes on the scalp that are 10 cm or more apart.

Using the 10/20 International System of electrode placement, the average distance between electrodes in an adult is 6 to 6.5 cm. Activity recorded using these distances and at a normal display sensitivity may suggest ECS. However if the same activity was recorded using longer inter-electrode distances, some activity might be seen. Therefore some double distance electrode linkages are recommended for example FP1-C3, F3-P3, and C3-O1 etc.

Display sensitivities of a minimum of 2  $\mu$  V/mm are required. However digital EEG systems have the added advantage of having sensitivity values of 1.5 and 1  $\mu$  V/mm. This 50-100 % increase in sensitivity will allow a more confident assessment of the presence or absence of a 2 $\mu$ V signal. The EEG is also used to investigate other conditions that may affect brain function such as strokes, brain injuries, liver and kidney disease and dementia.

### **EEG Activity**

EEG activity can be broken down into 4 distinct frequency bands:

Beta activity > 13 Hz

Alpha activity 8 Hz-13 Hz

Theta activity 4 Hz-7 Hz

Delta activity < 4 Hz

Beta activity is a normal activity present when the eyes are open or closed. It tends to be seen in the channels recorded from the Centre or front of the head. Some drugs will increase the amount of beta activity in the EEG.



*Beta activity*

Alpha activity is also a normal activity when present in waking adults. It is mainly seen in the channels recorded from the back of the head. It is fairly symmetrical and has amplitude of 40  $\mu$ V to 100  $\mu$ V. It is only seen when the eyes are closed and should disappear or reduce in amplitude when the eyes are open.

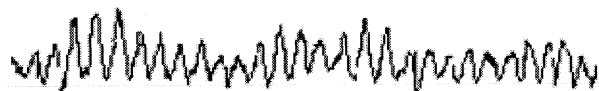

*Alpha activity*

Theta activity can be classed as both a normal and abnormal activity depending on the age and state of the patient. In adults it is normal if the patient is drowsy. However it can also indicate brain dysfunction if it is seen in a patient who is alert and awake. In younger patients,

theta activity may be the main activity seen in channels recorded from the back and central areas of the head.



*Theta activity*

Delta activity is only normal in an adult patient if they are in a moderate to deep sleep. If it is seen at any other time it would indicate brain dysfunction.

Abnormal activity may be seen in all or some channels depending on the underlying brain problem.



*Delta activity*

There are a number of other waveforms, which tend to be a little more specific to certain conditions. For example spike and wave activity indicates a seizure disorder and may be seen in the EEG even if the patient is not having an epileptic seizure. Other epileptic conditions may be diagnosed if spikes or sharp waves are seen.



*Spike and wave activity*

Triphasic waves are sometimes seen if the patient has severe liver or kidney disease that is affecting brain function.

These are just brief descriptions of some of the simpler waveforms that may be seen in any one EEG recording. Combinations of any of the above patterns are possible which can make interpretation of the record difficult. Abnormal activity is not always specific to any condition and may suggest a few different diagnoses.

## **ATYPICAL BUT NORMAL WAVE FORMS**

### **Lambda and POSTS**

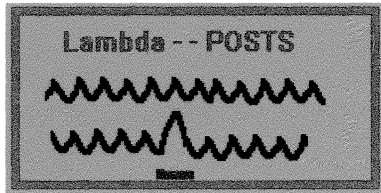

Lambda and POSTS are similar morphologically, and have a triangular shape. They occur posteriorly and symmetrically. POSTS stand for 'positive occipital transients of sleep' and occur in stage 2 sleep. Lambda occurs in the awake patient when the eyes stare at blank surfaces. Both are normal waveforms and can occur singly or in long or short runs.

### **K Complexes**

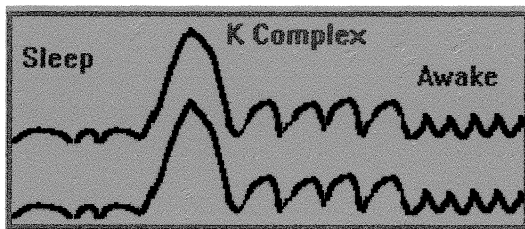

K Complexes occur in sleep when aroused - thus K complexes are seen with noises or other stimuli especially in stage 2 sleep. The K complex is often followed by an arousal response - namely a run of theta waves of high amplitude. Following this the EEG shows sleep again or the awake state.

### **V Waves**

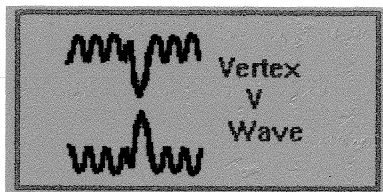

V waves occur in the parasagittal areas of the two sides and take the form of sharp waves or even spikes which show in the biparietal regions(vertex) with phase reversal at the midline in transverse montages or at the vertex in front-to-back ones. They are seen in stage 2 sleep along with spindles, K complexes, POSTS, etc.

### **MU activity**

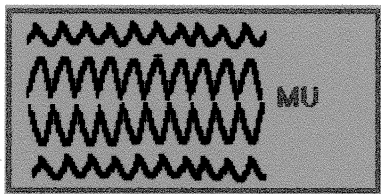

Mu activity is a rhythm in which the waves have a shape suggestive of a wicket fence with sharp tips and rounded bases. It may show phase reversal between two channels. The frequency is generally half of the fast activity present.

### **Psychomotor Variant**

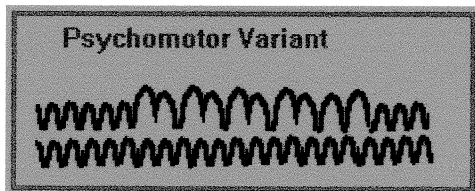

Psychomotor variant is a rare rhythm, which appears to be an harmonic of two or more basic rhythms causing a complex form. As can be seen it is higher in amplitude than the surround and the waves have a notched appearance. It is quite asymmetrical and is often mistaken for paroxysmal activity. It is benign.

## Fourteen and Six Rhythm

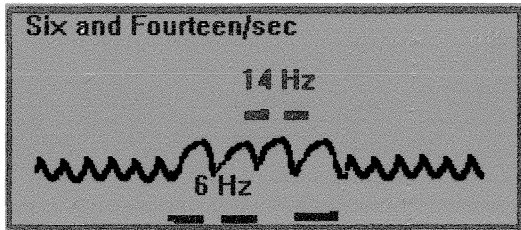

Fourteen and six activity is most often seen in children and adolescents. As seen it takes the form of 6 Hz and 14 Hz waves sometimes going in the same direction (up or down) and in others in opposite directions. It is typically seen in sleep or drowsiness and is usually seen in Monopolar recordings.

### EEG Recording

The EEG recording can last from anything between 15 minutes to 1 hour or longer depending on the situation. Typically the patient will be lying down or sitting relaxed in a chair. Most of the recording is taken with the eyes closed, although the patient will be frequently asked to open them for short periods.

Most patients will be asked to carry out a period of deep breathing for approximately 3 minutes. This may produce some abnormal activity, which would not be seen while the patient is relaxed. The physiological effect of deep breathing is to increase the amount of carbon dioxide (CO<sub>2</sub>) being removed from the bloodstream. This fall in CO<sub>2</sub> produces a fall in blood pressure and at the same time blood vessels in the brain become constricted. This reduces blood flow and the delivery of oxygen and glucose to the brain. This in turn may produce some abnormal brain activity not seen in the resting record.

Photic stimulation is also carried out. A strobe lamp is placed 30 cm from the patient's eyes. Brief flashes of light (2 - 5 seconds in duration) at a number of different flash frequencies are delivered to the patient with both eyes open and eyes closed. A continuous flash with increasing and decreasing flash frequencies is sometimes used. Some patients who are sensitive to flashing lights may show abnormal activity in the EEG.

Throughout the test the recordist is constantly annotating the record with any patient movements, or tasks that they are carrying out.

Other signals may also be recorded in conjunction with the EEG such as heart rate (ECG), respiration, eye movements (EOG), and muscle activity (EMG).

### EEG Analysis

The EEG reports consist of a number of different sections. The recordist may prepare a report describing the type of activity seen in the record together with changes produced by deep breathing and photic stimulation. They will also comment on the patient's state during the recording. The physician will then interpret these changes with regard to the medical problem being investigated.

With an increase in the number of long recordings being carried out, many departments make use of detection algorithms such as spike and seizure detection. Although it is still necessary for the clinician to review the complete record, such programmes will mark and highlight sections of interest. The most efficient method of implementing these algorithms is for the detection to be carried out on-line.

Other methods of analyzing EEG data include Power Spectrum Analysis. A Fast Fourier Transform (FFT) is performed on sections of EEG data to determine the power content of the four main frequency bands. The resulting waveforms can be displayed as a brain map, which will show the scalp distribution of the power within each frequency band. The amplitude of the different waveforms at a single point can also be displayed in a similar format. This type of display provides a more objective analysis of the EEG activity compared to a subjective visual analysis by a physician

## **ACTIVATION PROCEDURES**

Various activation procedures can elicit or enhance certain normal as well as abnormal activity in the EEG. The following are the most commonly used activation procedures performed in most of the laboratories.

### **Hyperventilation**

Hyperventilation is perhaps the most widely used activation procedures in EEG laboratories. This is a very simple and relatively safe procedure, consisting of three to five minutes' deep breathing at the rate of about 20 per minute. The most striking EEG abnormality seen during hyperventilation is the 3 Hz spike and wave discharges often brought on in patients with absence seizures. It is preferable to avoid in patients with recent stroke or subarachnoid hemorrhage, myocardial infarction, chronic obstructive pulmonary disease and other conditions causing difficulty in breathing.

### **Intermittent Photic Stimulation**

Visual stimuli are perhaps one of the most effective means of stimulation of the brain. Stroboscopes otherwise known as Photic stimulators are used for the purpose. Single or continuous bright flashes of light at frequencies ranging from 1 to 50 flashes per second are used. Flashes of duration 10 micro second with an intensity of 1.5 million foot candles are routinely given. Photic stimulation is most valuable in documenting photosensitivity, which has a correlation with primary generalized epilepsy. The flash lamp is positioned 30 cm in front of the eyes. Each flash rate is presented for a duration of about 10 seconds, and the eyes are kept closed in the first 5 seconds and are kept opened in the next 5 seconds. The IPS should be stopped if photo paroxysmal responses are obtained in order to avoid the precipitation of seizure.

### **Sleep deprivation and Sleep**

In the last several years sleep recording have become routine procedure in many EEG laboratories for eliciting epileptiform abnormalities. The augmenting effect of sleep is both in generalized as well as in focal epilepsies, especially in-patient with temporal lobe foci. In the majority of patients with epilepsy a generalized epileptiform discharges may become may be evident only during sleep. A dramatic increase in spike discharges during drowsiness and light sleep is a characteristic feature of benign rolandic epilepsy.

### **Pharmacological Activation**

A number of pharmacological agents have been used to induce epileptiform activities in patients with seizure disorder, the purpose being to determine whether one is dealing with a primary generalized or a focal onset seizure. It is not commonly employed in routine EEG although it finds its place in Electrographic.

## **SCTIMST protocol for EEG Recording**

Sleep deprivation: not more than 3-4 hours of sleep during Previous night

Ensure clean, dry and oil-free scalp hair

Advise to have medications and food as usual

During recording, try to obtain natural sleep. Use chloral hydrate, if necessary, 25mg/kg for children and 100mg for adults.

Duration of recording: not less than 20 minutes awake and 20 minutes sleep recording. If wake alone, not less than 30 minutes.

Technologists should inquire about any precipitating factor(s) (Such as eating, reading, calculation and light and pattern sensitivity) for seizures, and incorporate it during recording for provocation.

Technologist should check for skull deformities and defects and sketch them in the diagram.

Before starting each recording the technologist should check the electrode impedance.

Any clinical events noticed during the recording should be noted down and immediately informed to the doctor on duty.

<u>Sl.No</u>	<u>Patient's Name</u>	<u>Age/Sex</u>	<u>Hospital No</u>	<u>Diagnosis</u>
1	Abu Thahir.K.P	19/M	232650	Complex Partial Seizures
2	Biniha Basheer	16/F	185493	Scotosensitive Epilepsy
3	Rohit Thomas	8M/M	233258	West Syndrome
4	Preethi. A	17/F	221101	Mitochondrial Cytopathy
5	Biou. A	34/M	198081	Focal Seizures
6	Raja. R	32/M	235936	Generalised Tonic Clonic Seizures
7	Arunashree.J.S	9/F	236123	Hypnagogic Jerks
8	Saraswathy Amma	48/F	235950	Syncope Vs Seizure
9	Adarsa. T. S	21/F	235640	Opt. Suprasellar Crerminoma
10	Achu. S. Nair	15/M	236616	Localisation Related Epilepsy

<u>Sl.No</u>	<u>Patient's Name</u>	<u>Age/Sex</u>	<u>Hospital No</u>	<u>Diagnosis</u>
11.	Viswambharan Nair	58/M	205373	Late Onset Seizures
12	Pankajashy	66/F	9800657	Post M.V.R
13	George Korhy. P	67/M	237022	Transient Global Amnesia
14	Ibrahim. P.P	14/M	903068	Right ATL- Syrs Post Optic
15	Nejyumudeen. S	34/M	9405021	Nocturnal Gr.T.C.S
16	Krishnakumar. P.K	7/M	224567	L. G. S- Callosotomy
17	Reji. R.R	13/M	193354	Benign Rolandic Epilepsy
18	Sajid. A.S	3/M	231606	Atypical L.K.S
19	Archa Vijayan	11/F	211380	Primary Generalised Epilepsy
20	Soumya Rachel .C	18/F	213754	Left Parietal A.V.M

<u>Sl.No</u>	<u>Patient's Name</u>	<u>Age/Sex</u>	<u>Hospital No</u>	<u>Diagnosis</u>
21	Latha. S	25/F	9709653	J. M. E
22	Alwin Paul	14/M	211181	Right Occipital Lesionectomy
23	Sreelthi. P	6/F	237426	Simple febrile Seizure
24	Abraham. K. J	<sup>46,</sup> 39/M	237359	Creutzfeldt-Jakob Disease
25	Anju. B. Nair	16/F	197682	Absence - Photosensitivity
26	Karthika	1/F	237381	Static Encephalopathy
27	Vmesh. K. R	15/M	237020	Right Frontal F. C. D
28	Tom Shree	5/M	213293	L. G. S
29	Aparna	9/F	199421	A. D. H. D
30	Shiju Lal	21/M	9804649	Arachnoid Cyst

<u>Sl.No</u>	<u>Patient's Name</u>	<u>Age/Sex</u>	<u>Hospital No</u>	<u>Diagnosis</u>
31	Dili . D	4/M	234886	Post meningitis Hydrocephalus
32	Anilkumar . M . R	32/M	237048	Nacrolepsy
33	Ebrahim Rawther	63/M	237591	Alzheimer's Disease
34	Sandhya . G . R	18/F	237243	Non Epileptic Events
35	Jubesh . K	20/M	234417	Occipital Lobe Epilepsy
35	Manoharan . S	38/M	237268	Left Frontal S . O . L
37	Anu . S . Appukuttan	20/M	9800469	Complex Absence
38	Biju . L	30/M	237657	Viral Encephalitis
39	Rajadurai . M	20/M	234990	Lesional Encephalitis
40	Anees . A	7/M	238062	S . S . P . E

<u>Sl.No</u>	<u>Patient's Name</u>	<u>Age/Sex</u>	<u>Hospital No</u>	<u>Diagnosis</u>
41	Sreekala. M. C	28/F	220581	Post Opt. T.O.F
42	Suhara Beevi. M	63/F	9709316	Parkinson Plus Syndrome
43	Nivya	8/F	207878	Childhood Absence
44	Gaurav Aggarwal	5/M	238272	Developmental Delay
45	Mujeeb Rahman	16/M	238280	P. M. E
46	Neelakanda Iyer	75/M	237517	E. P. C
47	Abhishek. R	7/M	190412	Benign Occipital Epilepsy
48	Subin Biju	3/M	238549	Autism
49	Manuel. G	68/M	236680	T. B. Meningitis
50	Venki tesh. R	7/M	238621	Infantile Spasms

<u>Sl.No</u>	<u>Patient's Name</u>	<u>Age/Sex</u>	<u>Hospital No</u>	<u>Diagnosis</u>
51	Abhrami. K.V	14/F	238519	PolyMorphic Seizures
52	Suma. J	21/F	238094	Infantile Hemiplegia
53	Ajith Kumar	23/M	9810315	Right M.T.S
54	Pallav. V.K	14/M	238822	Hypoparathyroidism
55	Aaron. N. Duke	18/M	187071	I. G. E
56	B/o Sindhu. S	6/M	9806961	Maternal Seizure Evaluation
57	Ansar. K	10/M	216474	Hypothalamic Haemotoma
58	Asha John	13/F	9907559	Benign Myoclonic Epilepsy
59	Jaber. A	23/M	240888	CPS - Extra Temporal
60	Balagopal. S	58/M	242116	Alcoholic Seizure

<u>Sl.No</u>	<u>Patient's Name</u>	<u>Age/Sex</u>	<u>Hospital No</u>	<u>Diagnosis</u>
61	Sreedevi.T	28/F	195579	Eating Epilepsy
62	Dhanya.B	5/F	241934	Complex febrile Seizure
63	Afsal Basheer	12/M	242464	Non Epileptic Events
64	Akhil	10/M	9805289	Hypothalamic Glioma
65	Manu George A	14/M	242808	Dyslexia
66	Siddarth	6/M	231797	TBM with sequelae
67	Shobha.T.P	37/F	242573	Corpus Callosum Lesion
68	Silki Husaina	52/F	242202	Meningioma
69	Kichu	5/M	211220	V.S.D. closure
70	Athira.S.K	17/F	243352	Intermittent Porphyrria

<u>Sl.No</u>	<u>Patient's Name</u>	<u>Age/Sex</u>	<u>Hospital No</u>	<u>Diagnosis</u>
71	Muhammed Jabir	14/M	185255	M.E.L.A.S
72	Gurdit Singh	8/M	243451	Rassmussen's Encephalitis
73	Shafeeq P.K	16/M	240053	Intractable Epilepsy
74	Jaya Ramalingam P	3 <sup>4</sup> /M	243524	Tuberosis Sclerosis
75	Vasudevan N	64/M	209635	Post Stroke Seizure
76	Niza N	28/M	232693	Viral Encephalitis
77	Jayaraj	49/M	223439	Post Opt: A.V.R
78	Ismail M	33/M	243176	Right Vascular Glioma
79	B/o Krishna Kumari	48D/M	243930	Neonatal Seizure
80	Deepa V.V	28/F	224780	Herpes Simplex Encephalitis

<u>Sl.No</u>	<u>Patient's Name</u>	<u>Age/Sex</u>	<u>Hospital No</u>	<u>Diagnosis</u>
81	Suma Soman	18/F	9608131	Status Epilepticus
82	Prabhulla Nath.M	15/M	244442	Reading Epilepsy
83	Sandhya.T	24/F	244725	A.D.E.M
84	Jaimz .C	45/M	244253	Cortical Myoclonic Jerks
85	Athma .Y. Das	14/M	239918	Opt. Frontal Cavernoma
86	Suseela Lazer	56/F	245716	B.E.C.T
87	Jissmol Sojan	7/F	244452	F.C.D
88	Seema Mohan	27/F	245873	Symptomatic Seizure
89	Nilthya Nandini	12/F	246351	Right Parietal A.V.M
90	Sumith .B	6/M	247103	Adrenoleukodystrophy

<u>Sl.No</u>	<u>Patient's Name</u>	<u>Age/Sex</u>	<u>Hospital No</u>	<u>Diagnosis</u>
91	Thalaimali	53/M	246917	Olfactory Groove Meningioma
92	Aji George	30/M	8104699	Cephalic Seizures
93	Ann. P. David	2/F	231718	G.E.F.S
94	Sajeena B	28/F	247478	P.G.E
95	Nandan Rajesh	14/F	248251	Atypical Fesile Seizure
96	Darsana M	9/F	209573	Left Hemiplegia
97	Athul. Krishnan	14/M	239636	Absence
98	Prasanna M.P	53/M	248959	Clastic Seizures
99	Petchi Muthu	36/M	200763	Right ATL+AH
100	Vsha. T.V	34/F	218898	T.L.E

## **EEG MONITORING IN INTENSIVE CARE SETUP**

EEG provides a unique way of monitoring cerebral function in the intensive care unit and it is useful both for recording short and long acting events. Typically, epileptic spikes may last for a fraction of seconds, but recordings for many hours, for example during sleep cycles may also give important information. Recordings lasted for many days also be useful, to reflect slow trend changes in the EEG.

One basic requirement for an EEG monitor in the ICU is that has to present the original EEG on a monitor display, and also has to provide a paper printout. Another additional benefit would be to have the system continuously store signals. This would allow access to previously stored EEGs for inspection if unexpected, rapid changes, such as seizures, should occur.

It would be beneficial for the ICU clinician's daily work to understand the basics of EEG. It would be even better if the clinicians were able to identify typical EEG patterns such as physiological activity, pathologically slowed rhythms, seizure activity in its various forms, periodic patterns, and burst suppression. It discusses the utilization of the EEG in monitoring comatose patients in the ICU .The selected aspects include reactivity, periodic patterns, and burst suppression that may characterize an EEG in the ICU.

Recording of an EEG should be utilized more in the monitoring of comatose ICU patients. The EEG recording, repeated at intervals, can help with broad diagnostic categorization. In special clinical situations, for example in monitoring of the effectiveness of status epilepticus treatment, continuous monitoring of EEG could be deemed obligatory. In the assessment of the clinical importance of EEG patterns, clinical picture, age, etiology, acuity, and the integrity of the brainstem reflexes must be taken into consideration.

Another factor is that special EEG patterns, like triphasic waves, may suggest metabolic disturbances, which could be caused by liver dysfunction or toxic substances. From clinical and neuropsychological point of view, it is important to test reactivity of EEG. In general reactivity can be considered as a feature of the lighter stages of coma. However, even during deep anesthesia, with EEG at the burst suppression level, reactions to minor somatosensory, auditory, or visual stimuli can sometimes be seen.

<u>Sl.No</u>	<u>Patient's Name</u>	<u>Age/Sex</u>	<u>Hospital No</u>	<u>Diagnosis</u>
1.	Jayasree. K.V	30/F	22/146	Right Temporo Occipital Glioma
2.	Deepika. R	64/F	252326	Metabolic Encephalopathy
3.	Unni. C.R	42/M	252982	Two Episodes of GTCs
4.	Lawrence. D	53/M	253470	Aneurysm Coiled
5.	Sreeja. S.K	25/F	9003820	Left Focal Seizures
6.	Shahana. N	13/F	253469	Left Temporal - A.V.M
7.	Thomas. K.S	56/M	253392	Focal Twitching
8.	Chandra sekharan Nair	75/M	9902178	Mild Giddiness
9.	Anoop. C.U	15/M	250389	Post Operated Mixed Glioma
10.	Anvar Abdulla	31/M	252255	Encephalitis

<u>Sl.No</u>	<u>Patient's Name</u>	<u>Age/Sex</u>	<u>Hospital No</u>	<u>Diagnosis</u>
11.	Vinod .D	25/M	253573	Progressive Myoclonic Ataxia
12.	Jyothish.K.B	16/M	9300301	For Seizure Classification
13.	Rajamma.K.G	76/F	9104298	Non Convulsive Status
14.	Molly Mathew	52/F	9906152	Seizure Classification
15.	Sivaraman Nair	77/M	254815	Encephalopathy
16.	Brahmanandan	75/M	246065	Left M. V.A
17.	Vaishnav	5M/M	253979	N. C. S. E
18	Packia Sagaram	59/M	9700799	Right Focal Seizure
19	Suji. S	17/F	255609	P. M. E
20.	Rev. Mathew.T.John	40/M	234936	C. P. S

<u>Sl.No</u>	<u>Patient's Name</u>	<u>Age/Sex</u>	<u>Hospital No</u>	<u>Diagnosis</u>
21.	Aditya Sree	3/M	256288	ADEM
22.	Aloysious Xavier	56/M	256272	To R/o Brain Death
23.	Gurdit Singh	9/M	243451	Rasmussen's Encephalitis
24.	Saji Thomas	35 <sup>yr</sup> /M	220782	Recurrent Pituitary Adenoma
25.	Thankaraj	59/M	256671	Hypoxic Encephalopathy
26.	Vijin Vincent	8/M	213984	Static Encephalopathy
27.	Janaki.M.J	11M/F	256027	To R/o N.C.S.E
28.	Jogy.T	15/M	251719	CPS- Extra Temporal
29.	Appukutlan Nair	70/M	257169	Hypoxic Encephalopathy
30.	Anjali.S.S	18/f	192683	C.P.S

## **Prolonged Video EEG Monitoring**

Video-electroencephalography (VEEG) monitoring provides long-term recording of the electroencephalogram (EEG) and time locked video of the patient in a dedicating recording room. It is the most definitive method for the differentiation of seizure versus nonseizure events, classification of seizure types and localization of seizure onset. The clinical features helpful in distinguishing between temporal and extra temporal complex partial seizure. VEEG has an important role in the pre -surgical evaluation of patients with medically refractory epilepsy.

Scalp disk electrodes placed according to 10/20 system of placement. Special electrodes may be placed when indicated (e.g.: anterior temporal electrodes, sphenoidal electrodes) At least 16 channels of EEG and one channel of EKG should be monitored. The events can be detected by patient's caregivers triggered an event signal, a trained EEG technologist who visually scanned the VEEG or a computer equipped spike and seizure detection programme. Samples of inter ictal EEG and events are identified and then reviewed.

Analysis of some paroxysmal events may suggest alternative diagnosis including e.g.; syncope, psychogenic seizures, sleep disorders, paroxysmal movement disorder and other causes of episodically distributed behavioral surgical management.

### **Recording method**

#### Facilities

A room, close friends or relatives, medical team

#### Duration of monitoring

3 to 7 days

#### Scalp electrodes

10-20 international electrode placement is used T1 and T2 electrodes located below F7-F8 or T3 -T4 positions. Some used T1 &T2 electrodes to differentiate as activity arising from the focus rostral to the sylvian fissure in the frontal lobe and an anterior temporal source.

The maximal field of epileptiform activity in patients with complex partial seizure can be seen.

### **Invasive monitoring**

Patients may require invasive monitoring when the results of noninvasive methods such as scalp EEG, VEEG and MRI are conflicting. Placing sphenoidal electrode under fluoroscopy directly below the foramen ovale resulted in better detection of interictal and ictal epileptiform activity of mesial-basal-temporal origin. Several types of intracranial recording electrodes such as subdural strip and grid electrodes, epidural electrodes, intracerebral depth electrodes or combination of each are used.

<u>Sl.No</u>	<u>Patient's Name</u>	<u>Age/Sex</u>	<u>Hospital No</u>	<u>Diagnosis</u>
1	Sankar .R	35/M	250225	CPS - Temporal
2	Zenul Abedin .R	18/M	249689	CPS - Extratemporal
3	Kinjal Rohit .S	19/M	250222	CPS - Temporal Etiology
4	Paresh .O.H	15/M	250220	Bilateral Perisylvian Gliosis
5.	Rajasekhar .P	43/F	249675	Right Hemispheric CPS
6	Jincy Joseph	22/F	246891	CPS - Temporal
7	Krishna Kumar .T	30/M	246885	CPS - Temporal
8	Hariyadav .K	23/M	250521	Left Parietal Gliosis
9	Jameskutty .A	39/M	246595	Left M.T.S
10	Vasant Rao	61/M	250504	Extratemporal C.P.S

<u>Sl.No</u>	<u>Patient's Name</u>	<u>Age/Sex</u>	<u>Hospital No</u>	<u>Diagnosis</u>
11	Ruta. L.K	24/F	236792	CPS - Temporal
12	Ajeesh Kumar. J	15/M	9908853	CPS - Right Hemisphere
13	Gursewak Singh	14/M	246083	CPS - Right P-O F. C. D
14	Sulekha. K.B	30/F	242458	CPS - Right Temporal
15	Biju. T.K	30/M	250201	CPS - Temporal
16	Timiri Sai. A	26/F	250828	Left Opercular Gliosis
17	Aneesh Kumar. P	27/M	250218	Infantile Hemiparesis
18	Joby. C.T	32/M	251281	CPS Temporal
19	Vanaja. P	24/F	247038	CPS - Temporal
20	Shiji Kuttan	18/F	221198	Neocortical CPS

<u>Sl.No</u>	<u>Patient's Name</u>	<u>Age/Sex</u>	<u>Hospital No</u>	<u>Diagnosis</u>
21	Mathan.P	3/M	251555	CPS - Extra Temporal
22	Parvathi Venugopal	4/F	251223	Childhood Myoclonic Epilepsy
23	Lalit Mohan.K	16/M	192153	Left M.T.S
24	Dr. Nitika	<sup>25</sup> 25/F	248148	Left Temporal Calcified Lesion
25	Ilayakumar	31/M	252420	CPS - Right Temporal
26	Rajeesh.K.R	26/M	251509	Non Epileptic Behavioral
27	Hussain.I	40/M	30195	Left M.T.S
28	Amurtha.D	6/F	252523	Post Encephalitic Sequelae
29	Sudha Devakumari	35/F	9509779	Temporal Neocortical CPS
30	Ghosh.T.K	39/M	197328	Intractable CPS

<u>Sl.No</u>	<u>Patient's Name</u>	<u>Age/Sex</u>	<u>Hospital No</u>	<u>Diagnosis</u>
31	Seena Cyraic	30/F	247659	CPS- Frontal
32	Vishnu. V	13/M	251838	CPS- Left Hemispheric
33	Joby John	6/M	251573	Unprovoked-Unclassified
34	Jinesh. M	26/M	208426	CPS- Post Encephalitis
35	Varsha. N.C	13/F	222964	CPS- Left Hemispheric
36	Ragi Chandran. A	18/F	210193	CPS- Left Hemisphere
37	Sreejith	13/M	241449	Left Temporal Ganglioglioma
38	Nujumudeen. A	25/M	251847	Right M.T.-5
39	Parag. V. Bajaj	19/M	252146	Right Frontal Polymicrogyria
40	Uday. K. Sathesh	18/M	8801375	Complex Partial Seizures

<u>Sl.No</u>	<u>Patient's Name</u>	<u>Age/Sex</u>	<u>Hospital No</u>	<u>Diagnosis</u>
				Right Parietal Resection
41	Manvitha Shetty	11/F	226464	Right Parietal Grid - 32 Grid
42	Anoop Sai	25/M	228053	Left Occipital Gliosis Bilateral Hippocampal Depth Left Occipital Depth
43	Divya Gupta	26/F	246557	Right M.T.S Bilateral Hippocampal Depth - 8 Depth
44	Tadikonda .U	22/F	237017	C.P.S - Bilateral Occipital Bilateral Occipital Strip Placement
45	Pretty Pande	44/F	229500	C.P.S - Right Temporal Bilateral Hippocampal - 6 Contact Depth
46	Mahesh Reghmath	35/M	237550	C.P.S - Temporal Bilateral Hippocampal Depth - 6 contact
47	Sheetal Madankal	30/M	247886	C.P.S - Left Parietal Left Parietal Grid - 48 contact
48	Favook. C.K	33/M	237261	C.P.S - Temporal Bilateral Hippocampal Depth - 6 contact
49	Rajani Kaurva	34/F	253839	Intractable CPS - Temporal Bilateral Hippocampal Depth - 6 Contact
50	Anantha .R	24/M	237521	Left Temporal C.P.S Bilateral Hippocampal Depth - 6 contact

## **Electrocorticography**

It is one of the first important applications of intraoperative recording of cerebral electrical activity; later, depth recordings were made acutely during the course of epilepsy. Electrocorticography during epilepsy surgery has been performed for several years. In particular is this true for the tailored resections both temporal and extra temporal in order to identify the epileptogenic zone. Techniques for preoperative localization of motor and sensor gyri with electrical cortical stimulation and SEP recordings with subdural strip electrodes have been developed and are also used in the resection of intracranial tumors close to these eloquent cortical regions.

Preoperative nerve stimulation is used in the neurosurgical reconstruction of peripheral nerve and plexus brachialis lesions. SEP recordings in patients operated for tethered spinal cord, scoliosis or intraspinal tumors monitor the spinal cord function. The method of preoperative electrical cortical stimulation in spinal cord monitoring will be introduced shortly. Dorsal root stimulation is used during the dorsal rizotomy procedure to reduce spasticity in children with cerebral palsy and spastic diplegi. The function of the facial nerve is monitored in the resection of acoustics neurinoma.

<u>Sl.No</u>	<u>Patient's Name</u>	<u>Age/Sex</u>	<u>Hospital No</u>	<u>Procedure Done</u>
1	Manish Maheshwari	31/M	247932	Left Anterior Temporal Lobectomy + Amygdalohippocampectomy
2	Shameera.A.C	24/F	241417	Right Anterior Temporal Lobectomy + Amygdalohippocampectomy
3	Saifudeen. S	31/M	224983	Left Anterior Temporal Lobectomy + Amygdalohippocampectomy
4	Dinesh . S.K	34/M	237559	Right Anterior Temporal Lobectomy + Amygdalohippocampectomy
5	Jaya. L	30/F	236427	Left Anterior Temporal Lobectomy

## **POLYSOMNOGRAPHY**

A polysomnogram consists of a simultaneous recording of multiple physiologic parameters related to sleep and wakefulness. The interaction of various organ systems during sleep and wakefulness is also evaluated.

Polysomnography (PSG) is used to evaluate abnormalities of sleep and/or wakefulness and other physiologic disorders that have an impact on or are related to sleep and/or wakefulness.

By international standards, a polysomnogram must have a minimum of 4 neurophysiologic channels.

- One electroencephalography (EEG) channel (central with an ear reference provides the best amplitude) to monitor sleep stage
- Two electrooculogram (EOG) channels to monitor both horizontal and vertical eye movements (electrodes are placed at the right and left outer canthi, 1 above and 1 below the horizontal eye axis)
- One electromyography (EMG) channel (usually chin or mentalis and/or submental) to record atonia of rapid eye movement (REM) sleep

Other parameters often monitored include the following:

- Additional EEG channels, particularly in patients with sleep-related epilepsy
- Additional EMG channels, particularly anterior tibialis, to detect periodic limb movements of sleep
- Airflow
- Electrocardiography
- Pulse oximetry
- Respiratory effort
- Sound recordings to measure snoring

Optional parameters include the following:

- Continuous video monitoring of body positions
- Core body temperature
- Incident light intensity
- Penile tumescence
- Pressure and pH at various esophageal levels

In 1992, the Office of Technology Assessment of the Agency of Health Care Policy and Research recommended, in an evidence-based assessment, 2 tests as having been studied sufficiently. Both tests are performed in a sleep laboratory.

- Overnight polysomnography (oPSG) is an overnight recording of the patient's sleep.
- Multiple sleep latency testing (MSLT) records multiple naps throughout a day.

Standard sleep studies usually include both tests, oPSG (may be performed over several nights) followed by MSLT the next day. Limitations usually stem from the fact that recording conditions may not reflect what happens during a regular night in the patient's home. Although diagnosing a sleep problem on the basis of a recording over a single night is common practice, some authorities caution that more than 1 night of recording may be necessary, so the patient may become comfortable with unfamiliar surroundings and sleep more naturally. This effect is greatest on the first night in the sleep laboratory ("first night effect").

Sporadic events may be missed on a 1-night PSG. External factors that disturb the subject's sleep may be present in the home but absent from the controlled environment of the sleep lab.

Patient preparation is important so that the patient sleeps naturally. Patient instructions include the following:

- Maintain regular sleep-wake rhythm
- Avoid sleeping pills
- Avoid alcohol
- Avoid stimulants, including medications for narcolepsy
- Avoid strenuous exercise on the day of PSG testing

High costs and long waiting lists have prompted the exploration of alternative methods of evaluation. Although the following studies may have usefulness in specific clinical situations, Bloch concludes that their role compared to conventional sleep studies remains controversial.

- Ambulatory monitoring with portable equipment
- Daytime PSG

Simplified sleep studies with limited subsets of monitored parameters Automatic, computer-based systems often are employed in clinical and research settings. However, standard analysis still consists of tedious

and time-consuming review and scoring of either paper tracings or recordings projected on a computer monitor.

Overnight parameters (e.g.: times of lights on/off, total time in bed, total sleep time) are collected. The overnight recording is divided into epochs of approximately 30 seconds. The standard EEG, EMG, and EOG recordings are evaluated, and the predominant stage of sleep (according to the manual of Rechtschaffen and Kales) then is assigned to the entire epoch.

Total time and relative proportion of the night spent in each of the 6 stages and in REM and non-REM sleep are calculated. Latencies to REM and slow-wave sleep (SWS) are reported.

Special neurophysiologic events (e.g.: epileptic events, intrusion of alpha into sleep, periodic activity of tibialis anterior) are reported. Respiratory activity (e.g., apneic or hypopneic episodes, oxygen saturation) is correlated with sleep stages. Other parameters such as body position, gastro esophageal reflux, bruxism, and penile tumescence are recorded.

If a sleep apnea syndrome is diagnosed, a trial and titration of continuous positive airway pressure or a trial of an oral appliance may be undertaken, either in a partial-night or second-night PSG recording.

### **Dyssomnias (disorders of initiating or maintaining sleep)**

- Circadian rhythm disorders
- Narcolepsy
- Idiopathic hypersomnia
- Inadequate sleep hygiene
- Sleep-related respiratory disorders
  - Sleep apnea syndrome
  - Upper airway resistance syndrome

### **Parasomnias**

- Disorders of arousal
- Disorders of sleep-wake transition
- Disorders that occur during REM sleep
  - Nightmares
  - REM behavior disorder

- Medical-psychiatric sleep disorders
  - Medical - Sleep-related asthma
  - Psychiatric
    - Depression
    - Panic disorder
- Neurologic - Sleep-related epilepsy

- Others
  - Bruxism

Restless legs syndrome and periodic limb movement disorder

<u>Sl.No</u>	<u>Patient's Name</u>	<u>Age/Sex</u>	<u>Hospital No</u>	<u>Diagnosis</u>
1.	Kadia Sarjan.D	13/M	241466	Sleep Apnea
2.	Babu Krishna Prasad	60/M	241696	Sleep associated breathing disorder
3.	Subhash Bose.B	36/M	242151	Panic Attacks

# **ELECTROMYOGRAPHY**

## **Nerve Conduction Studies**

Nerves control the muscles in the body using electrical impulses. Whenever a muscle contracts (tenses up) in response to a signal from the brain, it produces an electrical discharge of its own. Electromyography (EMG) measures the electrical discharges made by the muscles. Nerve conduction studies measure how well individual nerves can transmit electrical signals.

Measuring the electrical activity in muscles and nerves can help detect the presence, location and extent of diseases that can damage muscle tissue (such as muscular dystrophy) or nerves (such as amyotrophic lateral sclerosis). In the case of nerve injury, the actual site of nerve damage can often be located. EMG and nerve conduction studies are often done together to provide more complete information.

The myelinated nerve axon conducts impulses in a saltatory fashion i.e. depolarisation occurs at the nodes. The currents are prevented from penetrating the membrane between the nodes in the normal nerve due to an isolating myelin sheath. This means that the impulse propagation is much faster than if there was a continuous depolarisation. The conduction velocity is also dependent on the axonal diameter and the properties of the membrane. A normal axon conducts with a speed of 35-60 m/sec. The velocity is reduced if the myelin is defect due to pathological changes, if the ion-channels at the nodal areas are blocked or if the axon diameter is smaller than normal. It is also dependent on temperature.

When the correlation between neurophysiological and morphological parameters was established, the nerve conduction study become an important method used in clinical routines [14; 15; 18;20;26;31]. Such studies are performed in most EMG laboratories since the 1960's and have since then become more sophisticated, sensitive and specific.

This summary will give a brief update of the nerve conduction studies, which are performed in clinical routine today.

### **General guidelines for performing nerve conduction studies**

Before attempting nerve conduction studies on patients one must consider a number of factors. First, the patient must be aware of what to expect. In addition the tester must prepare the anatomical part to be tested and must understand the potential problems that could arise.

1. Explain the procedure to the patient. It is important to explain the procedure to the patient in the simplest language to make the patient less anxious and more co-operative.
2. Place the limb to be tested in a relaxed and comfortable position both for the patient and for the examiner.
3. The stimulating and recording electrodes should be used as per the guidelines.
4. Measure the skin temperature to avoid errors. Motor and sensory nerve conduction velocities decrease at the rate of 1.3 to 2.4 m/sec per degree drop in skin temperature. During the nerve conduction studies the skin temperature is kept at 31 to 34 degree Celsius whenever possible or else the correction should be introduced.
5. The electrode impedance should be kept at minimum to avoid unnecessary artifacts.
6. A ground electrode should be attached to the lead being tested and is ideally placed between the stimulating and the recording electrodes.
7. Pediatric stimulating and recording electrodes are used in infants.
8. Motor nerve conduction studies are performed prior to sensory conduction study to locate nerves.
9. The patient should be warned before giving each stimulation.
10. The pain should be reduced as much as possible by adjusting the intensity and duration of the stimulus, but still within the supramaximal range.

## **Factors influencing nerve conduction parameters**

### **Temperature**

The temperature affects the conduction velocity (CV), both locally at the recording site and generally along the nerve.

Locally the amplitude increases as the temperature in the recording site decreases. The amplitude increases by 1.7% per degree Celsius

The temperature also affects the conduction along the nerve segment. The CV decreases as it cools with a factor ranging from 1.2 to 2.4 m/s per degree Celsius. This varies for different nerve [8]. This will reduce the amplitude. These two effects of the temperature on the amplitude neutralize each other. In order to standardize CV and amplitude measurements, it is recommended to keep the skin temperature at above 29° C for the dorsum of the hand and 27° C for the dorsum of the foot.

### **Age**

Conduction velocity is age dependent. Full term infants have conduction velocities, which are approximately half of that seen in adults. Conduction velocities rapidly increase from the values recorded in infants to near adult values at around 3-5 years of age. Furthermore pre-term infants have slower values at around 14-28 m/s. In the teens conduction velocities are almost the same as those of adult values

After the second to fourth decade, conduction velocities start to decrease very slowly. CV decrease by 0.5-1.8 m/s for each decade

### **Length of segment and height**

Longer nerves generally conduct more slowly than shorter nerves [5]. It has been shown that there is a good correlation between CV and estimated axonal length in the peroneal and sural nerves, but not in the motor or sensory fibers of the median nerve. Based on a good correlation between the height of the patient and the length of the nerve, the CV in lower limbs decreases by 2-3 m/s for 10 cm increase in height. Nerve impulses propagate faster in the proximal than in the distal nerve segments.

## Gender

It has been reported that CV is slower in women than that in men, but the correlation is complex since gender and height are not independent of each other. In our routine, we use the same reference values for women and men.

## Reference values

With standardized methods, the technique is sufficiently reproducible to allow the transfer of reference values from one laboratory to the other. A number of techniques and related reference values are given in the literature.

## Pathophysiology

The principle changes in nerve function are related to demyelination, axonal degeneration and conduction block. There are no absolute dividing lines between these situations; they show some overlap and also dynamic changes from one stage to another due to the interaction between Schwann cells and the axonal condition. In cases of demyelination, the conduction velocity is reduced. In cases of axonal degeneration, there may be normal velocity in the remaining axons, but a weaker muscle response is evoked. In cases of conduction block, no axonal degeneration occurs and therefore a normal response is obtained when stimulating distal to the lesion. When stimulation is performed proximal to the site of abnormality, a reduced number of axon conducts impulses, and a smaller than normal muscle response is obtained.

## **PROCEDURES**

### **Motor Conduction Studies**

#### **Recording electrode**

For motor conduction studies (MCS), recording is formed over the belly of the muscle using a surface electrode. The active recording electrode is placed over the endplate zone of the muscle in order to record muscle activity at the moment of depolarisation after the nerve impulse has arrived at the endplate. The muscle response, obtained after nerve stimulation is called the compound muscle action potential, CMAP, should have an abrupt negative take-off. If the electrode is away from the endplate, it will show an initial positive phase corresponding to the approaching electrical field of the impulses in the individual muscle fibers. The start of the positive phase corresponds to the start of the depolarisation. However, because of the gradual increase in amplitude from the baseline it may be difficult to determine the exact start. If later part of the CMAP is used for latency measurements, the latency value will be contaminated with some conduction time along muscle fibers and not express only the nerve conduction time. However, when comparing distal and proximal latencies for CV calculations, other points than the take-off can be used, as long as the same parts of the CMAPs are used. It should be mentioned that in some situations, particularly in recording from the abductor digiti minimi (ADM) muscle of the foot in the study of the tibial nerve, underlying muscles with different positions of the endplate zones would contribute to the recording and give rise to positive components. If possible, measurements should be made to the point where the signal leaves the baseline

#### **Reference electrode**

The reference electrode should be placed in such a way that no recordings are taken from the muscle under study. If the reference electrodes are too close to the muscle, e.g. in its tendon, it will contribute with a significant amount of activity. Therefore, more distal positions are preferred, e.g. over the distal interphalangeal joint (from the thumb for the median nerve, dig V for the ulnar nerve, toe one for the tibial nerve and toe V for the peroneal nerve).

## Stimulation

Usually stimulation is performed at two or more sites along the nerve. It is not adequate to stimulate at only one point and calculate the conduction velocity from the obtained latency between the stimulus and motor response and the distance. This is because the conduction time includes the slower in the conduction in the last segment of the nerve, time in the neuromuscular junction, and possibly some conduction along muscle fibers. Therefore, two stimulation sites well separated from each other along the nerve are used.

In situations of local nerve lesion, short segments should be tested in order to localize the site of the abnormality. This technique has been called "inching" using small distance between stimulation points. We often use distance of 10 mm ("centimetry"). The recording site is kept constant, and the stimulation is performed every 10 mm across the area of suspected lesion. The analysis should focus on sudden jumps with prolonged latency values with more proximal stimulation or abrupt drop in amplitude.

Sometimes somewhat longer segments of the nerve are studied as part of the routine. In ulnar nerve studies, stimulation is often made at the wrist, and above and below the elbow. In studies of the peroneal nerve, stimulation is made at the ankle, and below and above the fibula head. In cases of difference in conduction along the two segments, centimetry is performed.

Generally surface electrodes (felt pad or steel) are used in motor nerve conduction studies. They are fixed on to a plastic bar a fixed distance apart.

In a few situations it is preferable to use needle electrodes. A pair of monopolar needle electrodes is used these cases. Alternatively a surface electrode is used as an anode.

It is necessary to use needle electrodes when stimulating a nerve that is located very deeply. Therefore the muscle response can be obtained with less stimulus strength than the one necessary in surface electrodes. In short segment study the use of needle electrode provides more certain localization than that of surface electrodes.

The output impulse used for MCS is a rectangular wave with a duration of 0.1 or 0.2 ms. Sometimes it may be necessary to increase the stimulus duration to 0.5 or 1 ms in order to get maximal amplitude. In order to ascertain reliable maximal amplitude of the CMAP, it is advisable to increase the stimulus strength by 10-25% of that which is necessary to obtain maximal amplitude. In some situations a biphasic stimulus pulse is used in order to suppress stimulus artifacts.

## Parameters

A number of parameters are of interest in the assessment of different aspects of motor nerve functions.

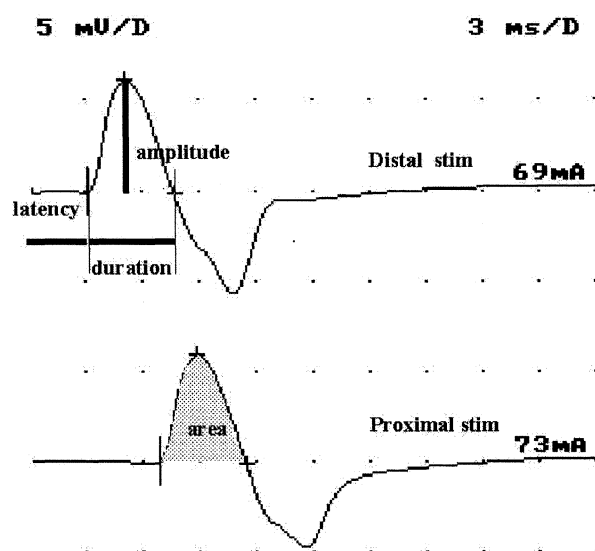

**Measured parameters of the CMAP. Distal (trace 1) and proximal (trace 2) stimulations are shown**

### Measured parameters

#### Latency (distal and proximal)

The latency is the time between the stimulus and the response. In motor nerve studies, this latency includes the nerve conduction time and also the neuromuscular transmission time. Distal latency is measured from the distal stimulation point to the first deflection from the baseline. Proximal latency starts at the proximal stimulation point and ends at the first deflection from the baseline.

### **Amplitude**

The amplitude (AMPL) of the evoked motor response carries important information. It is dependent on the number of axons that conduct impulses from the stimulus point to the muscle, the number of functioning motor endplates and the muscle volume. The amplitude is measured from the baseline to the negative peak.

### **Area**

The area represents a combination of the amplitude and the duration. It therefore reflects the number and synchrony of the muscle fibers activated. A prolongation of the duration can cause a decrease in the amplitude and may be misinterpreted as a conduction block. In this situation there may not be significant difference in the area. Area is the integrated area between the CMAP and the baseline.

### **Duration**

The duration (DUR) reflects the synchrony of individual muscle fiber discharges. If there is a significant difference in the conduction velocity among nerve fibers, the duration will be prolonged. This is mainly related to the range of the conduction velocities of the large myelinated fibers. Duration is measured from the onset to the first negative to positive baseline crossing.

### **Conduction velocity**

The conduction velocity (CV) is calculated by dividing the length of the nerve segment between the two stimulation points by the difference between the proximal and distal latency. In this way the slow distal conduction and any delay in the neuromuscular transmission is eliminated. It is calculated as follows.

$$CV \text{ (m/s)} = \text{distance (mm)} / \text{LAT}_{\text{prox}} - \text{LAT}_{\text{distal}}$$

When motor conduction velocity is calculated in this way it reflects the fastest motor axons.

### **Temporal dispersion**

Since nerve fibers have different conduction velocities, a more proximal stimulation site will give an increased duration of M wave. The change in duration with a proximal stimulation site is called temporal dispersion and is calculated as follows:

$$\text{DISPERSION} = 100 \times (\text{DUR}_{\text{prox}} - \text{DUR}_{\text{distal}}) / \text{DUR}_{\text{distal}}$$

In healthy subjects, the maximum dispersion in the ulnar nerve is 10-15%. In long nerve segments the CV may be lower and the dispersion higher than that seen in short segments.

### **Amplitude and Area Decay**

With proximal stimulation, when the duration of the M wave gets longer due to the temporal dispersion, the amplitude and the area of the M wave changes. Decay is calculated as shown in these formulas.

$$\text{AMPLDECAY} = 100 \times (\text{AMPL}_{\text{distal}} - \text{AMPL}_{\text{prox}}) / \text{AMPL}_{\text{distal}}$$

$$\text{AREADecAY} = 100 \times (\text{AREA}_{\text{distal}} - \text{AREA}_{\text{prox}}) / \text{AREA}_{\text{distal}}$$

In healthy subjects, the mean value of the AMPLDECAY is 4.5-6.2% in the ulnar nerve [and 5.6-7.7% in the median nerve]. The AMPLDECAY is larger in the lower extremities than in the upper extremities. The peroneal nerve has a mean value of 11% and an upper limit of 29% in the AMPLDECAY. On the other hand the AREADecAY is smaller than the AMPLDECAY in peroneal nerves.

## **Other motor parameters**

### **F-waves**

When the motor nerve is stimulated, nerve action potentials propagate both in the distal direction to evoke a muscle response, and in the proximal direction as a non-physiological event. Occasionally, the motor neuron depolarisation may evoke a recurrent response by stimulating the first node distal to the neuron. There is only a small chance that the timing of the depolarisation/repolarisation allows this to happen. Normally a recurrent response is evoked in 0.5-5% of the stimulations with some differences between nerves.

6

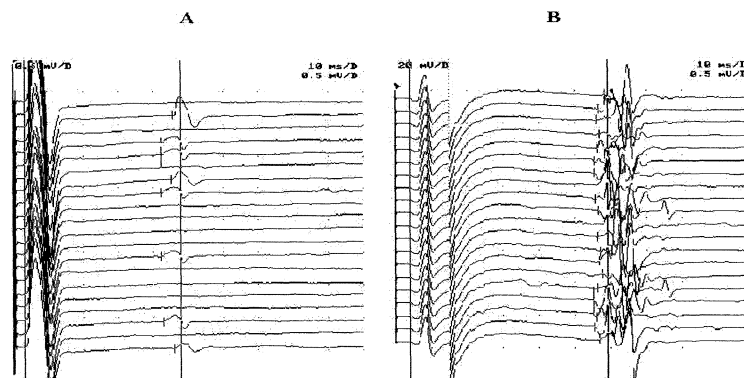

**Studies of F-waves in normal peroneal (A) and tibial nerves (B). Note the different occurrence of frequency of the F-waves in these two nerves.**

The F-waves travel from the stimulation point on the nerve to the neuron and back to the muscle. By subtracting the distal latency, the time taken from the stimulus point to the neuron and back again to the stimulus point can be obtained. This time depends on the conduction distance involved. Instead of measuring the extremity length, we relate the reference values to the height of the patient since arm and leg length are normally correlated to height.

Since each normal nerve contains hundreds of motor axons, it is usual to obtain 5-15 F-waves from 20 stimulations. They differ in latency and shape since they normally represent activity from different motor

units. The frequency of occurrence is reduced when there is a conduction block anywhere along the nerve. F-wave measurements thus reflect conduction along the entire nerve and are therefore particularly useful in the study of general polyneuropathy and also when proximal segments are preferentially involved, as in Guillain-Barré syndrome, GBS.

### **M-satellites (often called A-waves)**

M-satellites are responses usually occurring between the CMAP and the F-wave. They have a constant shape and latency and occur in at least 10 per 20 stimulations. In normal conditions they are only seen in the tibial nerve. They are present in various pathological conditions but are unspecific in relation to a given diagnosis. An M-satellite may be generated as an extra discharge in the stimulated axon (intermediate double discharges, IDD), be due to emphatic transmission between two axons, axon reflex or represent the response from one axon with exceptionally slow conduction velocity. They are for example seen during the first days of GBS representing IDD.

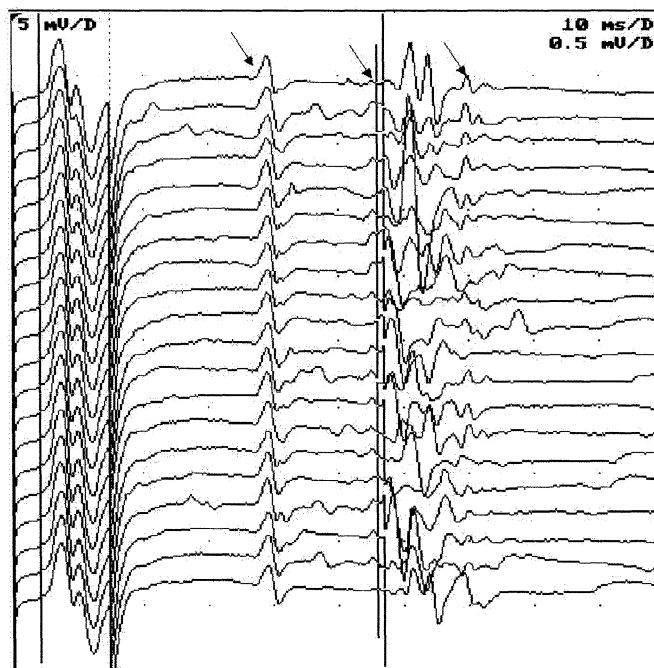

**M-satellites (arrows) seen in the tibial nerve in a patient with normal conduction velocity. The two vertical lines indicate upper normal limit (right) and the estimated shortest F-latency among the obtained responses (left line). The F-wave latency is thus minimally increased. The number of F-waves is normal.**

## H-waves

An H-reflex is a monosynaptic reflex that can be elicited by the stimulation of muscle spindle afferents in the limbs. It is possible to evoke H reflexes on most nerves during the first year of life. In adults it can most easily be elicited in the calf muscles and flexor carpi radialis. The H reflex recorded from calf muscles - gastrocnemius, soleus - is mediated via the S<sub>1</sub> root. The H reflex recorded from the flexor carpi radialis is mediated C<sub>7</sub> root .

The H-reflex and F-wave differ in some aspects. The H-reflex contains a sensory and a motor branch. The H-reflex is studied only with a sub maximal stimulus and is abolished by supramaximal stimulation. Although consecutive F waves vary in latency and waveform, H reflexes remain constant in response to repetitive stimuli. This is because H reflexes occur from activating the same motor neuron pool. In contrast F-waves represent recurrent discharges from different groups of motor neurons with different conduction characteristics.

H-reflexes may be obtained more easily if a long stimulus duration is used i.e. 0.5 or 1 ms. The H reflex habituates and decreases in amplitude with stimulation rates > 0.5 Hz. The voluntary activation of the investigated muscle or Jendrassic's maneuver will enhance the H-reflex amplitude and shorten the latency.

**Summary of parameters**

The most common motor neurography parameters are summarized in Table 1.

**Table 1.**

Parameter	Significance	Usually measured as	Analysis mode
<b><u>CMAP</u></b>			
Ampl	# axons, synchronisation	neg. amplitude (mV)	a/m
Area	# axons, “	neg. area (mV *ms)	A
Dur	neg. peak duration	(ms)	
Ampl decay	Cond. block + dispersion	% reduction in ampl	a
Dispersion	axonal velocity disp	% increase in dur	A
CV	velocity of fastest axons	latency diff. (m/s)	a/m
Distal latency	velocity of fastest axons	latency	a/m
<b><u>F-waves</u></b>			
Latency	cond. of axons along entire nerve	Lat (min, mean in ms)	
Dispersion	axonal velocity dispersion	Min and max lat (ms)	a/m
# Of F-waves	# axons and MN excitability	# F-waves 20 stimuli	a/m
Amplitude	MUP shape + # F-waves	peak-peak ampl ( $\mu$ V)	a/m not often used
<b><u>M-satellites</u></b>			
Presence	Abnormal excitability or slowly conducting axons	present or not	M
<b><u>H-reflex</u></b>			
Latency	cond. along reflex arc	H-lat minus M-lat (ms)	a
Amplitude	excitability	M ampl / H ampl	a

*Table 1. Note: CMAP = compound muscle action potential; CV= conduction velocity; MN = motor neuron.*

### **Analysis**

All modern EMG systems have programs for neurography. Many have algorithms for automatic measurements. These algorithms vary and reference values may therefore differ somewhat between laboratories.

### **Motor conduction block**

One of the parameters in nerve conduction studies concerns the presence of impulse conduction blocks, CB. A Conduction block is the failure of an action potential to propagate throughout the length of a structurally intact axon. This may be seen at the site of a local nerve entrapment and is typical of autoimmune neuropathies (Guillain-Barré, GBS; chronic inflammatory demyelinating polyneuropathy, CIDP) and in multifocal motor neuropathy with persistent conduction block, MMN. In the hereditary demyelinating polyneuropathies, conduction block is seen only to a slight degree. Other polyneuropathies do not usually show conduction block.

The principal finding is the blocking of an impulse across a local segment without axonal damage. Therefore, stimulation distal to the block gives a normal CMAP whereas a proximal stimulation produces decreased amplitude.

This is normally studied in two ways in the motor nerve; by comparing CMAP at distal and proximal stimulation and by the assessment of the F-wave frequency.

In MCS, there is normally a slightly lower amplitude for proximal stimulation compared with distal and also a slight temporal dispersion. This can be explained simply as the difference in the conduction velocity between individual axons. This gives rise to an incomplete summation of signals and even some degree of so called phase cancellation. The longer the distance, the more pronounced these changes are. These effects are more pronounced in cases of slow conduction velocity due to demyelination, particularly when there is an increased spectrum of velocities among the axons. This means that when a reduction of the CMAP is obtained at proximal stimulation compared to distal response, the differential diagnostic problem is demyelination with general slowing causing abnormal temporal dispersion vs. a pure conduction block. In the first case, the distal-proximal amplitude drop is parallel to the temporal dispersion as

expressed by the change in CMAP duration. With pure CB, there is no increase in temporal dispersion.

There have been several attempts to define criteria for conduction block. To discriminate between "pure" demyelination and a conduction block, the following criteria have been suggested (Ad Hoc Subcommittee of the American Academy of Neurology AIDS Task Force 1991):

Conduction block is present if there is

>20% AMPLDECAY or AREADDECAY and <5% DISPERSION or if there is >50% AMPLDECAY or AREADDECAY, independent of DISPERSION.

It has been [22] demonstrated that both these criteria are equally sensitive in detecting a block.

Our own modifications of these rules are:

>25% (arm) or >40% (leg) AMPLDECAY and <15% DISPERSION or if there is

>50% AMPLDECAY, independent of DISPERSION (in this case there is a combination of CB and demyelination)

The other parameter, which indicates CB, is the frequency of occurrence of F-waves. In cases of proximal CB, there may be no drop in amplitude in the distal part of the nerve, e.g. in early GBS. In this case, the CB can be seen by a reduction in the occurrence of F-waves. The normal frequency of F-waves varies for different motor nerves. When 20 stimuli are given in a normal situation the different nerves normally show the following numbers of F-waves: ulnar 18, median 15, peroneal 10, and tibial 18. As can be seen, it is impossible to detect a slight reduction in the number of F-waves in the ulnar and peroneal nerve. Lack of response is usually taken as an abnormal finding. In the tibial nerve, a better assessment of pathology can be made. It should be noted that in the interpretation of the number of F-waves, the CMAP amplitude needs to be considered. If the CMAP is reduced to half due to axonal degeneration, then the expected number of F-waves is correspondingly reduced.

The number of F-responses should also always be reduced when conventional MCS has shown a conduction block; otherwise a technical error is to suspect in the measurements.

### **Anatomical variants**

In normal subjects, there could be some anatomical variations in the muscle innervation. Martin-Gruber anastomosis is the most common anomalous innervation of the hand with an incidence of 15-28% [17].

The fibers innervating intrinsic muscles of the hand cross from the median nerve to the ulnar nerve. Sensory fibers are not involved. Martin-Gruber anastomosis can be divided into three types according to the muscle innervated by the crossing fibers. The most common type is type II, in which the crossing fibers innervate first dorsal interosseus muscle. When the anastomotic fibers end in the ADM and abductor pollicis brevis the MG is classified as type I and type III respectively. Type III is the least common. Stimulating the median and ulnar nerves and recording from the muscles mentioned above can reveal martin-Gruber anastomosis. The amplitude of the CMAP wave evoked by the median nerve stimulation at the elbow is found higher than the one evoked by stimulation at wrist level when recording is performed by muscle with anomalous innervation. The CAMP obtained at the proximal site also has an initial small positive deflection because of the volume of conduction from the deep ulnar innervated muscles. In type I the amplitude of the M wave from the ulnar nerve stimulation shows a reverse discrepancy; lower with elbow stimulation and higher with wrist stimulation.

8

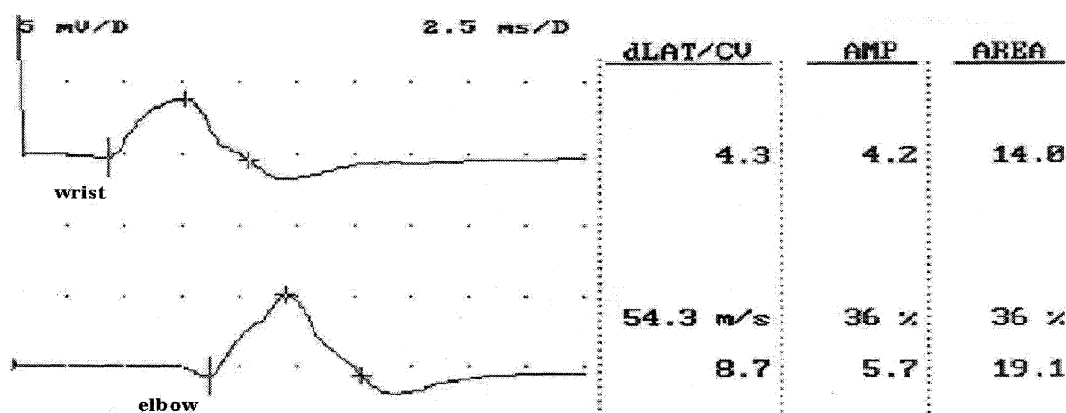

**Median nerve MCS in a case of Martin-Gruber anastomosis. Note the higher amplitude and the initial positive going phase at stimulation at elbow.**

When this anastomosis accompanies the carpal tunnel syndrome (CTS), an abnormally fast conduction velocity value, in the forearm segment of the median nerve is found, due to delayed DLAT but a "normal" PLAT.

Another common anatomical variation is the innervation of the extensor digitorum brevis by the accessory peroneal nerve. The deep

peroneal nerve normally supplies this muscle. In 23 to 28 percent of population, the superficial branch, behind the lateral malleolus, innervates it. When a low CMAP is obtained distally, stimulation should always be performed behind the malleolus.

Schematic summary of the relationship between CV and amplitude parameters in axonal (low amplitude) and demyelinating (low CV) neuropathy.

**Table 2.**

	Demyelination	Axonal degeneration	Conduction block
CV and dist latency		n/	N
Amplitude	n/↓	↓ ↓	↓
Amplitude decay	n/	N	
Dispersion		N	
F-wave latency		n/	N
# Of F-waves	n/↓	↓	↓

*Table 2. Note: Classical findings in neurography at different types of pathology. = increased; ↓ = decreased; n= normal*

## **Sensory Conduction Studies**

The pathophysiological principles regarding sensory nerves are the same as those discussed for motor nerves. Sensory neurography differs in some aspects: The amplitudes are much smaller than those in MCS and since the recordings are carried out on the nerve itself. Furthermore, only one stimulation site is necessary for calculating CV. The stimulation recording can be performed in both the orthodromic or antidromic direction. Some of these things will now be discussed.

### **Recording electrode**

The recording may be performed orthodromically or antidromically. The conduction velocity is the same but other parameters are different. In some instances one choice is preferred, but in other cases the choice is based on tradition. Table 3 shows differences between ortho and anti-dromic methods.

**Table 3.** Differences between orthodromic and antidromic nerve stimulation

Orthodromic	Antidromic
No muscle artifact (+)	Less painful (+)
More painful	Larger amplitude (+)
Lower amplitude	Muscle artifact in mixed nerves

Usually surface electrodes are used for recording purpose. The electrodes may be so called ring electrodes, e.g. around the digits. More commonly we use felt pad electrodes with a fixed interelectrode distance between the two recording poles. The electrode is placed along the nerve with the "active" towards the point of stimulation.

If the electrode is placed along the nerve, the two poles record an identical signal, often biphasic in shape with an initial smaller positivity and a larger positive part. In the amplifier the two signals are subtracted, giving rise to a triphasic configuration. The shape, in particular the duration and amplitude of the recorded signal is dependent on the conduction time between the two poles (distance and CV). This means that, the interelectrode distance has to be kept constant within the laboratory.

Reference data must be collected using the same technique that is used in routine studies.

In cases when near nerve needle electrodes are used, all the parameters except CV are different. In this case a special needle electrode is inserted just outside the nerve (the position may sometimes be tested by using the electrode for stimulation. An optimal position is found when a muscle response is obtained with minimal current, often less than 2 mA). The recording may show multiple peaks indicating the difference in conduction velocity among individual axons. This is particularly apparent in cases of pathology. Amplitude parameters are dependent on both the needle position in relation to the nerve, and the distance between the stimulation and recording. It is often not very reproducible in pathology. We use needle electrodes in Morton's metatarsalgia and meralgia paresthetica.

### **Stimulation**

Stimulation can be performed with a surface electrode, or with a needle electrode. In the first and more common case, the electrode is placed over a sensory nerve, or sometimes over the relevant skin area. The stimulus duration is often 0.1 ms and the frequency around 1 Hz. The stimulus strength is increased, as long the recorded response is increases. With higher stimulus strength, the increase in pain and, depending on the stimulus site, the motor artifacts may significantly disturb the recordings. Here an optimum must be found. When a needle electrode is used, similar considerations should be made. In our study we used needle electrodes to obtain high selectivity, e.g. in the stimulation of individual digital nerves in cases of Morton's metatarsalgia.

## Parameters

Parameters and a typical recording from the ulnar sensory nerve are shown below.

10

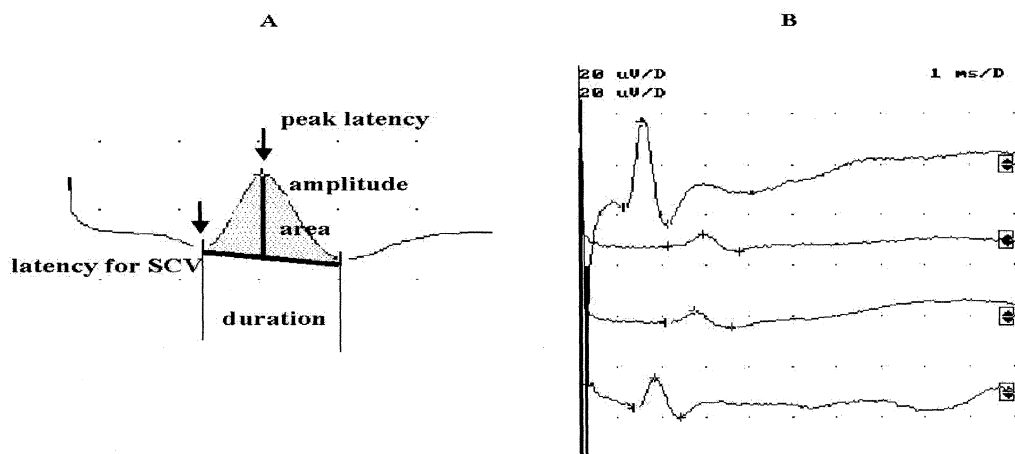

Sensory nerve action potential. A= parameters, used in all nerve studies. B= Sensory conduction studies in the ulnar nerve. Averaged responses obtained orthodromically at the wrist with stimulation at palm, dig IV and dig V (traces 1-3). Antidromic sensory response obtained in the interdigital space between metacarpals IV and V and stimulating the dorsal ulnar branch. In cases of entrapment at the Guyon's canal, this response is normal, while the digital responses are abnormal.

### Latency (distal and proximal)

The latency is the time from the stimulus to the first positive peak of sensory nerve action potential (SNAP). If there is no clear positive peak in antidromic recording, the latency is measured from the take-off from baseline.

For the normal latency of a nerve there should be approximately two hundred nerve fibers conducting normally and having 10 m V or more of diameter [26].

Some laboratories have a tradition of measuring latency to the first negative peak. Since negative peak latency includes the rise time of SNAP and indicates the temporal dispersion, it is not recommended to use negative peak latency to calculate the CV.

### **Amplitude**

The amplitude of the SNAP should be measured from the first positive peak to the highest negative peak. Some authors measure the amplitude as the maximum peak-to-peak amplitude or as the amplitude between a line joining the positive peaks as the positive value and the negative peak.

The amplitude reflects the number of nerve fibers having a diameter of 9 m V or more.

### **Area**

The area is the integrated area between the signal and baseline over the DUR.

The area represents the combination of amplitude and duration; therefore this reflects the number and synchrony of the activated nerve fibers.

### **Duration**

The duration is measured from the first positive peak to the last positive peak. When there is no presence of the initial positive peak, the duration is measured from take-off on the baseline.

### **Conduction velocity**

The conduction velocity (CV) is calculated by dividing the length of the nerve segment from the stimulus point to the recording point by the positive peak latency. It should be calculated as follows.

$CV \text{ (m/s)} = \text{distance (mm)} / \text{LAT}$

When the sensory conduction velocity is calculated in this way, it reflects the conduction velocity of the fastest sensory fibers.

### **Temporal dispersion and decay**

Since physiologic temporal dispersion affects the sensory action potential more than the muscle response, these parameters are not easily used in the routine studies. This is due to the difference in duration of individual unit discharges between nerve and muscle. With

short-duration diphasic sensory spikes, a slight latency difference could line up the positive peaks of the fast fibers with the negative peaks of the slow fibers, cancelling both.

**Table 4.**

Parameter	Significance	Usually measured as	Analysis mode	Comment
Latency	conduction velocity	positive peak (ms)	a/m	
CV	conduction velocity	distance/latency (m/s)	a/m	
Amplitude	# axons, temporal disp	peak-peak ( $\mu$ V)	a/m	
Area	# axons, temporal disp	total area ( $\mu$ V * ms)	A	
Duration	dispersion	pos.-pos. peak dur (ms)	a/m	
Late components	conduction dispersion	shape	M	in needle rec.

*Table 4 showing parameters usually measured in sensory neurography. Note: for explanation, see Table 1.*

### **Analysis**

Modern EMG equipment has programs to measure these parameters. Often averaging is necessary in order to obtain a good signal to noise ratio.

### **Autonomic nerve testing**

It should be noted that this is important in the general neurophysiological investigation of a patient with neuropathy. Some of the most commonly used methods are indicated in Table 6.

### Autonomic tests

Autonomic testing includes Heart rate variation	
(At deep breathing, Valsalva, tilt test)	parasympathetic (sympathetic)
SSR	Sympathetic
Pletysmography	Sympathetic

## ELECTROMYOGRAPHY

### Volitional Activity in Muscle

#### Motor Unit Potentials

*Electromyography* (EMG) is the science involved with the study of electrical activity in muscle. The basic physiologic unit of normal skeletal muscle function is the *motor unit*, which consists of a *lower motor neuron (LMN)* and a finite number of muscle cells (fibers). When a LMN discharges in response to volitional or reflexive activation, an action potential is propagated along its axon (nerve fiber), chemically recreated at end plates, and then propagated along muscle cell membranes just prior to muscle contraction. The composite electrical activity in muscle cell membranes when a motor unit discharges is called a *motor unit potential (MUP)*. The size of a single MUP depends upon the type and size of the motor unit and the proximity of the unit to the recording electrode. Primary muscle disease may cause MUP durations and amplitudes to decrease (due to loss of individual fibers).

Manipulating posture or using reflexes to induce movement can record motor unit potentials. In some neurogenic diseases, the durations and amplitudes of MUP increase due to increases in innervation ratios caused by collaterization and reinnervation. These unusually large MUP have been referred to as *giant motor unit potentials*. During periods of active degeneration, MUP may show slightly increased durations and amplitudes. The presence of polyphasic MUP may point to conduction impairment in smaller intramuscular nerve terminals.

### Interference Patterns

Normal volitional muscle contraction is brought about by the repetitive asynchronous activation of large numbers of motor units. Recruitment is the process of adding motor units to ones that are already active thus increasing the force of contraction. Electromyographically, the pattern of muscle contraction during normal physiologic activity is called an *interference pattern* because the individual MUP are so numerous, they seem to "interfere" with each other in a recording. Depending upon the intensity of muscle contraction, the interference pattern may be called *complete* or *incomplete*. The interference pattern can be recorded from single muscles with intramuscular monopolar needle electrodes or fine wire electrodes. Both type of electrodes are insulated except for the tip of the needle or wire. These procedures allow for an evaluation of a specific muscle with little to no interference from other muscles. Fine wire electrodes, for example, have been used successfully in small animals to assess the function and synergistic action of the external urethral sphincter during cystometrography. In peripheral neuropathies, the interference pattern is markedly reduced or completely lost.

### Evoked Activity in Muscle

In a clinical setting, skeletal muscle activity is usually evoked by electrical stimulation of motor nerves while intramuscular needle or surface electrodes are used as recording electrodes. In other evoked responses, receptors are physiologically stimulated and muscles are reflexively activated. Muscle activity may also be produced by electrical or electromagnetic stimulation of the motor cortex. Mechanical injury to muscles by needle recording electrodes will also evoke activity. Electrical or reflexive activation of muscles will be described in other briefs.

### Insertion Potentials

Other than end-plate noise, normal muscle membranes are electrically silent if there is no LMN activity. However, when a needle electrode is inserted into or moved in a normal healthy muscle, it is accompanied by electrical activity called *insertion potentials*. Insertion potentials are caused by the mechanical stimulation of muscle fibers and usually cease when needle movement ceases. As described below, insertion potentials may be prolonged in neuropathic or myopathic disorders

and mixed with other abnormal potentials such as positive sharp waves and fibrillation potentials. Insertion potentials may be reduced in severely atrophied muscle.

### Spontaneous Activity in Muscle

Spontaneous activity in muscle, when it occurs, may be initiated in the perikaryon of the LMN, its peripheral axon, the end plate, or the muscle membrane itself. As mentioned previously, if skeletal muscle is not volitionally or reflexively activated, it is electrically quiescent, therefore, most spontaneous activity in muscle is often associated with neuromuscular abnormalities

### Miniature End-Plate Potentials

Each skeletal muscle cell is innervated by a single branch of the LMN axon at a synapse referred to as the *end plate*. In the absence of LMN activation, spontaneous activity in muscle is only recorded in the *motor point*, an area in the muscle where there is a high concentration of end plates. This activity may be recorded by needle electrodes and referred to as *end-plate noise*, which consists of large numbers of *miniature end-plate potentials (MEPP)*. A single MEPP is a non-propagated calcium-dependent potential caused by a small number of neurotransmitter packets being released spontaneously at the end plate. Motor end-plate noise as well as other muscle potentials described below can be recorded with intramuscular needle electrodes.

### Fasciculation Potentials

*Fasciculation* is the spontaneous twitch that occurs when motor units or parts of neighboring motor units discharge. Electrically, fasciculation's have durations, amplitudes and other characteristics similar to MUP. Recent findings suggest that benign fasciculation's are caused by emphatically activated muscle fibers as a result of discharge in pacemaker fibers in either nerve or muscle. Although very little tension is produced, fasciculation can sometimes be observed through the skin. Fasciculation can be seen in a variety of diseases affecting nerve and muscle, and infrequently in degenerative diseases affecting the spinal gray matter.

### Fibrillation Potentials.

*Fibrillation potentials (fibs)* are brief spontaneous bi- or triphasic potentials that are seen in neurogenic and primary muscle disease. This potential, also called a *denervation potential*, is one of the electrical hallmarks of partially or completely denervated muscle and is produced by the discharge of a single muscle fiber. The amplitude of fibrillation potentials may range from 50-350 mV with durations of 1-2 msec. Fibs appear in denervated muscle after a latent period that is proportional to the length of remaining axons distal to the site of a nerve lesion. Their onset may be preceded by periods of increased insertional activity. Once these potentials appear in denervated muscle, their rate of occurrence increases over a period of several weeks. They will persist until muscle is reinnervated, or until no viable muscle fibers remain. Fibrillation potentials are also seen in myopathic disorders such as muscular dystrophies, polymyositis, and dermatomyositis. Their origin is related to oscillating membrane changes or irregular prepotentials caused by membrane instability. In neuropathies, where the primary feature is demyelination, fibrillation potentials may not be found. The sound of these potentials from a loudspeaker has been likened to crackling cellophane.

### Positive Sharp Waves.

*Positive sharp waves (PSW)*, like fibrillation potentials, occurs when muscle is denervated, but also occur in a variety of myopathic disorders. In denervation, PSW may precede fibrillation potentials by one or more days. The special feature of the PSW is the initial positive phase followed by a more gradual negative-going phase. By convention, EMG recorders are configured such that positive potentials produce a downward deflection in the recording. These potentials make a lower pitched sound than fibrillation potentials and usually have a lower discharge rate.

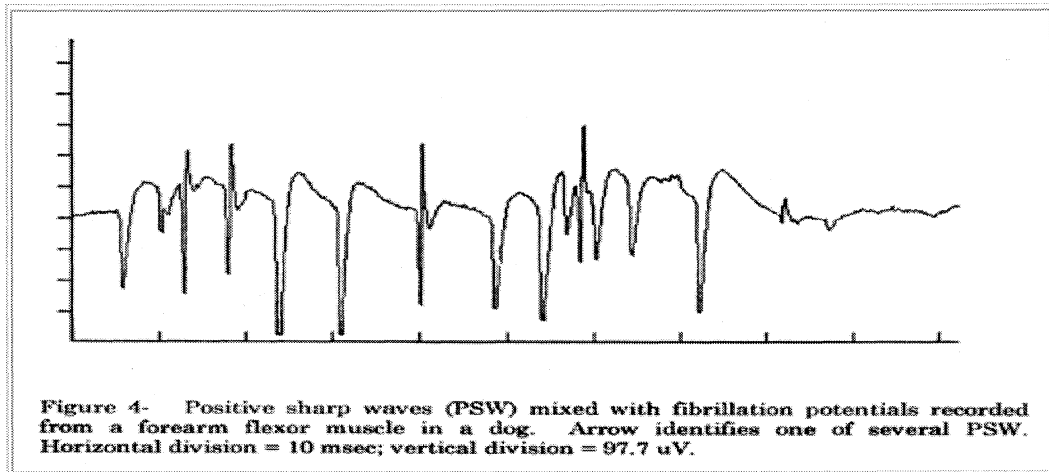

### Bizarre High Frequency Discharges.

*Bizarre high frequency (BHF)* activity consists of polyphasic potentials that discharge spontaneously at a high frequency. Within the train of discharges, each potential may have precisely the same appearance. Such behavior suggests the presence of pacemaker muscle fibers that oscillate. The onset may be associated with needle movement and the discharges start and stop abruptly. These potentials can occur in a variety of myopathic conditions including hyperadrenocorticism, and polymyositis. Some have referred to these as *pseudomyotonic potentials* because they do not wax and wane like true myotonic potentials. From the loudspeaker of the electromyograph, these discharges have continuous high-pitched motor-like sounds.

### Myotonic Discharges.

*Myotonic potentials* occur in muscles as a result of permeability abnormalities in muscle fiber membranes. Muscles continue to be electrically activated even after the cessation of volitional contraction. These high frequency (100 to 200/sec) potentials spontaneously wax and wane in amplitude and rate in an EMG pattern that has become the electrical signature of myotonia. In addition to normal presynaptic nerve activity, mechanical muscle movement, or needle displacement may precipitate the onset. Spontaneous activity may last for a second or more, which persist in the presence of depolarizing and non-depolarizing muscle relaxants. In some types of myotonia, the repetitive discharges may be explained by altered chloride conductance in muscle membranes while in other types, the malady

may be related to a disorder in cation conductance. Audio monitoring of myotonic potentials reveal the most characteristic EMG sounds, that of a dive-bomber. For this reason, myotonic potentials are referred to as "dive-bomber potentials."

### **REPETITIVE NERVE STIMULATION**

Repetitive nerve stimulation (RNS) is used in the evaluation of patients with suspected neuromuscular transmission disorders (NMTD) such as myasthenia gravis (MG) or Lambert-Eaton myasthenic syndrome (LEMS). RNS is a modified motor NCS where instead of recording CMAPs with single supramaximal electrical stimuli, a train of 8–10 stimuli is applied and the sequential response amplitudes and/or areas measured. This may be carried out at low (3–4 Hz) or high frequency stimulation (20–50 Hz). In the latter case the train is prolonged to allow 2–10 seconds of continuous data to be measured. Both distal and proximal muscles/nerves should be studied in every patient suspected of an NMTD as the sensitivity of the test is greatly increased by this means.

With low frequency stimulation in normal subjects, the CMAP amplitude and/or area falls over the first 4–5 stimuli by a maximum of 10–12%. The maximum fall should be between potentials 1 and 2. A number of department specific protocols have been published to study the RNS over time both before and after a period of maximum voluntary contraction of the muscle to pick up early or late NMT failure. High frequency stimulation may be used to discover evidence of a post-synaptic transmitter release disorder like LEMS. It is painful and requires considerable patient tolerance. There is evidence that recording low frequency RNS immediately before and after a 20–30 second period of maximum voluntary contraction by the patient is equally sensitive and is more humane.

There are many pitfalls in the RNS test and artifact almost always gives rise to an abnormal test. Thus adherence to a strict protocol and heightened suspicion on the part of the CN to an abnormal result is essential as are repeated studies for reproducibility of abnormalities.

### **Physiological basis for the RNS**

The neuromuscular junction consists of the motor axon terminal, the synaptic cleft, and the post-synaptic muscle membrane. As the motor axon potential depolarizes the nerve terminal, voltage

gated calcium channels open increasing the concentration of calcium in the pre-synaptic nerve terminal. This in turn facilitates the release of quanta of acetylcholine (ACh) from the nerve terminal into the synaptic cleft. ACh binds to receptors on the post-synaptic membrane causing depolarisation (end plate potential). The size of the end plate potential is dependent on the amount of ACh released and its binding to receptors. In the healthy state, the end plate potential reaches a threshold level and causes an action potential to be propagated along a muscle fibre resulting in muscle contraction. Normally there is a large safety factor for neuromuscular transmission with the amount of ACh released per impulse several times that required to generate a threshold level end plate potential.

In low frequency RNS, the rate of stimulation is such that the end plate physiology is stressed, but not to the level that produces the natural facilitation of NMT at greater stimulation frequencies. Thus an abnormal fall (decrement) in CMAP amplitude and/or area at low stimulation rates indicates a drop in the safety factor for transmission whether from a pre- or post-synaptic cause.

In high frequency stimulation natural facilitation is enhanced by pre-synaptic  $Ca^{++}$  influx and this may counteract a process such as LEMS where quantal release is depressed.

### **BLINK REFLEX**

The cranial nerves that can be readily tested are the trigeminal (V), facial (VII), and spinal accessory (XI).

#### Facial (VII)

The facial nerve is examined by recording the latency and amplitude from a stimulus at only one site along the course of the nerve. Nerve conduction velocities are not calculated.

**Stimulation site:** Place the electrodes behind the angle of the jaw, with the cathode posterior to the earlobe and the anode behind. This placement stimulates the nerve just before it enters the parotid gland. Alternatively, you may place the cathode over the stylomastoid foramen and the anode over the mastoid.

**Ground:** Usually the ground is placed over the parotid area, but you may place it on the chin or forehead also.

**Recording sites:** Place the active recording over the orbicularis oris at the corner of the mouth, over the orbicularis oculi on the outer

canthus of the eye, over the frontalis in the forehead, or over the nasalis muscle on the nasolabial fold. Place the reference electrode on the nose. Either a needle or surface electrode may be used for recording.

The facial nerve may be evaluated differently - by using the blink reflex, which will be discussed with the trigeminal nerve (below).

### **Trigeminal**

Using reflex activity and extrapolating information from it evaluate this nerve.

A brief review of the anatomy will assure a better understanding of this study.

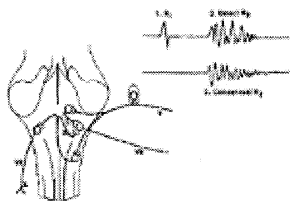

As the sensory fibers of the Vth nerve enter the brain stem, they establish three kinds of synaptic connections with the VIIth nerve nuclei:

- One, a direct and monosynaptic with the ipsilateral VIIth nerve nucleus.
- Another, indirect and polysynaptic with the contralateral VIIth nerve nucleus.
- A third, also polysynaptic, again to the ipsilateral VIIth nerve nucleus.

These connections are demonstrated clinically by the fact that when the glabella is lightly tapped with a reflex hammer or the finger, a brisk blinking reaction is seen bilaterally. The blink reflex is the electrical equivalent of this reaction referred to clinically as the glabellar reflex. Stimulation of the supraorbital branch of the Vth nerve as it enters the skull through the supraorbital foramen will result in contraction of the orbicularis oculi muscles bilaterally.

Using two channels on the cathode ray tube to study both sides simultaneously best performs the test.

One each side an active electrode is placed over the orbicularis oculi muscle on the outer canthus of the eye and the reference on the lateral aspect of the nose. One ground is used and is placed over the chin.

The Vth nerve is stimulated via its supraorbital branch over the supraorbital foramen; the sweep speed used is 10 msec/division and the gain set at 200  $\mu$ v/division. On the ipsilateral channel, both direct and indirect responses are seen, the direct of a short latency and mono or biphasic configuration, the indirect of a long, usually variable, latency and polyphasic configuration. On the contralateral channel, only the indirect, long latency polyphasic response is seen.

### **Blink Reflex Findings**

In unilateral Vth nerve lesions, all three responses are equally affected.

- In unilateral VIIth nerve lesions, stimulation on the same side of the lesion will result in delayed or absent direct and indirect responses ipsilaterally but a normal indirect response contralaterally. When the nerve is stimulated on the healthy side, both the direct and indirect responses are spared while the contralateral indirect response is affected.

The blink reflex can be used in the evaluation of toxic neuropathies and in comatose patients and multiple sclerosis as a means of evaluating brain stem functions.

<u>Sl.No</u>	<u>Patient's Name</u>	<u>Age/Sex</u>	<u>Hospital No</u>	<u>Diagnosis</u>
1	Kumaran.K	65/M	238753	Left Radial Nerve Palsy
2	Salim.S	53/M	238597	Ocular Myasthenia
3	Niji.G.S	23/M	238732	Mononeuritis Multiplex
4	Abirami.K.V	14/F	238519	Progressive Myoclonic Epilepsy
5	Mohammed Bohari	7/M	238640	Becker Muscular Dystrophy
6	Priya.R.S	26/F	2380807	Friedreich Ataxia
7	Prathapa Chandran	46/M	238671	Phenytoin induced Peripheral Neuropathy
8	Maggi Mathew	25/F	237195	Right Common Peroneal Neuropathy
9	Vijaya Raj.M	42/M	9200304	Hypokalaemic Periodic Paralysis
10	Manoj Kumar	37/M	9306805	Recurrent G.B.S

<u>Sl.No</u>	<u>Patient's Name</u>	<u>Age/Sex</u>	<u>Hospital No</u>	<u>Diagnosis</u>
11.	Francis Sebastian	55/M	238872	C8-T <sub>1</sub> Radiculopathy
12	Najeena. A	40/F	238996	Bilateral Carpal Tunnel Syndrome
13	Annavi. A	20/M	238967	Right Sciatic Neuropathy
14	Don. T. James	19/M	238881	Sensory Poly Neuropathy
15	Divakaran. P.K	76/M	238993	Diabetic Peripheral Neuropathy
16	Ushakumari. S	36/F	238428	Amyotrophic Lateral Sclerosis
17	Susheela	50/F	238819	Cervical Myopathy
18	Shalinimol. E	22/F	239042	Meralgia Paresthetica
19	Shini. V.S	32/F	238604	Cervical Cord Demyelination
20	Charles. A	74/M	196412	L5-S <sub>1</sub> Radiculopathy

<u>Sl.No</u>	<u>Patient's Name</u>	<u>Age/Sex</u>	<u>Hospital No</u>	<u>Diagnosis</u>
21	Julia	33/F	238108	Myasthenia Gravis
22	George. K.S	46/M	239140	Dysphagia
23	Sadasivan	63/M	8600350	Operated P.I.V.D
24	Sarathkumar.S	18 <sup>yr.</sup> /M	234493	Discal Myopathy
25	Sanjeev Menon	44/M	238895	Right Upper Limb Weakness
26	Dr.Gopinathan Nair	55/M	235922	Post Operated Spinal Neurofibroma
27	Indukala. S.S	26/F	239596	Numbness of both big toe
28	Jyothi	40/F	9603424	Left ptosis
29	Ameera Shamnad	20/F	238446	Critical Illness Neuropathy
30	Leela.M	38/F	9609195	Motor Neuron Disease

<u>Sl.No</u>	<u>Patient's Name</u>	<u>Age/Sex</u>	<u>Hospital No</u>	<u>Diagnosis</u>
31	Sasidharan Nair	55y/M	213397	Chemotherapy Induced Neuropathy
32	Sameel. S	15/M	239837	Spina Bulbar Atrophy
33	James Chacko	42/M	239961	Traumatic Brachial Plexopathy
34	Narayana Pillai	58 <sup>24</sup> /M	237915	C. I. D. P
35	Dr. Arya Nambalchiri	34/F	239310	Osteomalacia
36	Sadia. A	37/M	236196	Lumbar Cord Stenosis
37	Mohanan Nair	54/M	240070	Lumbo Sacral Plexopathy
38	Radhamma. B	50/F	240083	Cervical Myelo Radiculopathy
39	Sivasankara Pillai	73/M	239709	Right Bell's Palsy
40	Aming. P	55/F	239820	Thoracic Outlet Syndrome

<u>Sl.No</u>	<u>Patient's Name</u>	<u>Age/Sex</u>	<u>Hospital No</u>	<u>Diagnosis</u>
41	Murugan. S	34/M	240279	Anterior Horn Cell Disease
42	Yousaf. C	51/M	240323	Sensory Ataxia
43	Ponnamma. V	53/F	240341	Conus Myelitis
44	Mary Leena	32/F	240595	Vasculitic Neuropathy
45	Abbas. A	30/M	240461	Small fibre Neuropathy
46	Leelamma	40/F	239886	Polyneuritis Cranialis
47	Nandana	4/F	240486	M. E. R. R. F
48	Rohin Joseph	7/M	240724	Duchenne Muscular Dystrophy
49	Padmavathy. B	74/F	240895	Toxic Neuropathy
50	Saju Varghese. V	17/M	240830	H. M. S. N

<u>Sl.No</u>	<u>Patient's Name</u>	<u>Age/Sex</u>	<u>Hospital No</u>	<u>Diagnosis</u>
51	Bindhu. S	28/F	241059	Collagen Disorder
52	Seybi	25/M	9803387	Monomyelic Amyotrophy
53	Karthik	6/M	241112	Leukodystrophy
54	Muhammed. A	45/M	241201	Neurocanthocytosis
55	Vijaya lakshmi. P	37/F	240714	Progressive Proximal Myopathy
56	Suvendran Pillei	68/M	240259	Parkinson - Atypical
57	Sumaiya Beevi	21/F	241146	L. G. M. D
58	Sheriff. C. P	33/M	241499	Spindle cell Carcinoma
59	Palani. M	33/M	241504	Beckers Muscular Dystrophy
60	Alfas Shaji	2/M	241711	Congenital Myopathy

<u>Sl.No</u>	<u>Patient's Name</u>	<u>Age/Sex</u>	<u>Hospital No</u>	<u>Diagnosis</u>
61	Karunakaran	66/M	197979	Large Fibre Neuropathy
62	Vijaya Kumar. K	60/M	241709	Left C5-C6 Radiculopathy
63	Rajesh Kumar. S	20/M	241881	Right Femoral Neuropathy
64	Arul Mani	32/F	242075	Lower Limb Weakness
65	Sojan. M.P	25/M	243939	Hereditary Spasticity
66	Ratheesh	22/M	244280	Hirayama
67	Somarajan. P.K	58/M	245522	Post Polio Syndrome
68	Mong	50/M	9900605	Bulbo Spinal Atrophy
69	Mohanan Nair	48/M	245670	Cervical Myelopathy
70	Saji. P. John	28/M	246073	C. I. D. P.

<u>Sl.No</u>	<u>Patient's Name</u>	<u>Age/Sex</u>	<u>Hospital No</u>	<u>Diagnosis</u>
71	Thomas P.M	59/M	245642	Axonopathic Neuropathy
72	Anas. S	17/M	246352	Right M.C.A
73	Balan. M	22/M	246810	Miller Fischer Syndrome
74	Sreelatha. C.B	33/F	231547	Opt. Lumbar Disc
75	Oseela Beevi	43/F	246859	T-T-S
76	Aman. A	1/M	246338	SMA
77	Habeeba	45/F	146673	Mitochondrial Cytopathy
78	Gopalakrishnan. A	52/M	247032	Myotonic Dystrophy
79	Santhamma. K	65/F	247892	Dermatomyostosis
80	Joseph Maltew	28/M	247928	M.F.M.N

<u>Sl.No</u>	<u>Patient's Name</u>	<u>Age/Sex</u>	<u>Hospital No</u>	<u>Diagnosis</u>
81	Prema. P.M	27/F	247095	Steroid Myopathy
82	Robi Kumar	21/M	247826	Paramyotonia
83	Lijo Joseph	18/M	252105	Mytochondralis
84	Dr. S.N. Moorthy	58/M	252303	Low Back Ache
85	Dhanya. R	19/F	251634	Congenital Myasthenia
86	Saleena. M	17/F	252655	S.C.A
87	Maheswari Anna	69/M	253020	Neuralgic Amyotrophy
88	Antony. V	23/M	252858	A.D.E.M
89	Dr. K.G. Syam	50/M	258694	Numbness of sole
90	Jain Benance	36/M	253146	Neuro whipples

<u>Sl.No</u>	<u>Patient's Name</u>	<u>Age/Sex</u>	<u>Hospital No</u>	<u>Diagnosis</u>
91	Manu-M	6/M	253381	Duchenne Muscular Dystrophy
92	Mustafa.K.C	53/M	253379	Acromegaly
93	Sudheesh	18/M	234616	Adrenoleukodystrophy
94	Balaji	11/M	254248	Leigh's Disease
95	Beena.B	27/F	254300	Chronic Meningitis
96	SreeLekha.K.M	41/F	254116	Left Diaphragmatic Palsy
97	Rajendran Nair	35/M	254341	A.I. Neuropathy
98	Suresh Baby	42/M	254371	Right Suprascapular.
99	Radha	64/F	254606	Brachial Neuritis
100	Sandhya.O.K	30/F	258766	H.S.A.N.

## **EVOKED POTENTIALS**

## **Visual Evoked Potentials**

The VEP tests the function of the visual pathway from the retina to the occipital cortex. It measures the conduction of the visual pathways from the optic nerve, optic chiasm and optic radiations to the occipital cortex. The most important fact is to consider that, although the axons from the nasal half of the retina decussate at the optic chiasm, the temporal axons do not. Therefore, retrochiasmatic lesions may not be detected by full field checkerboard stimulation. VEPs are most useful in testing optic nerve function and less useful in postchiasmatic disorders. In retrochiasmatic lesions, the MRI is a more useful test. Partial field studies may be useful in retrochiasmatic lesions; however, they are not performed routinely in clinical settings. Also, note that the macula projects to the occipital pole, while the rest of the retina projects to the mesial calcarin cortex.

The VEP is very useful in detecting an anterior visual conduction disturbance. However, it is not specific with regard to the etiology. A tumor compressing the optic nerve, an ischemic disturbance, or a demyelinating disease may cause delaying the P100; only additional clinical history and, often, MRI are needed to uncover the etiology. The usual waveform is the initial negative peak (N1 or N75), followed by a large positive peak (P1 or P100) followed by another negative peak (N2 or N145). Maximum value for P100 is 115 ms in patients younger than 60 years; it rises to 120ms thereafter in females and 125 ms in males. Eventhough, published norms are available in the medical literature, each individual laboratory should have its own norms to control for lab-to-lab variability in technique.

The W morphology, is most often a individual variation, although decreasing the stimulation frequency from the ubiquitous 2Hz - 1 Hz usually converts the W shape into a conventional P100 peak. Check size and alternation rate are the factors in this; the response can be manipulate to a W or a conventional P100 response by changing these parameters. Large checks tend to produce VEPs similar to those produced by flash stimulation.

## **Technical Aspects**

Checkerboard pattern (or less often, flash) is used as stimulation. Responses are collected over OZ, O1, and O2 and with hemi field studies at T5 and T6 electrodes using the standard EEG electrode placement. Monocular stimulation is used to avoid masking of unilateral conduction abnormality. Sedation should be not be used, and note should be taken of medications that the patient is taking regularly. Testing circumstances should be standardized, including seating distance of 70-100 cm from the monitor screen, giving a check size of approximately 30 seconds of visual angle. The vision should be corrected to the extend possible in case of a visual problem. Pupil's size and any abnormality should be noted. The P100 waveform is at its maximum in the mid occipital area. Stimulus rates of 1-2 Hz are recommended, and filter setting should be 1-200 Hz bandwidth.

The recommended recording time window (sweep length) is 250ms; 50 – 200 responses are to be averaged. A minimum of 2 trials should be given. The responses are averaged and the P100 positive polarity waveform that appears in the posterior head region is analyzed. The mean latency is about 100 ms. Normative data should be assembled on a lab-by- lab basis.

<u>Sl.No</u>	<u>Patient's Name</u>	<u>Age/Sex</u>	<u>Hospital No</u>	<u>Diagnosis</u>
1.	Geetha Devi	20/F	245736	Optic Neuromyelitis
2.	Paulose.V.P	56/M	237546	Toxic Optic Neuropathy
3.	Neena Ancy.Z	27/F	251047	B/L Optic Neuritis
4.	Mohammed.A	47/M	251433	Cortical Visual Loss
5.	Sumitha. F	25/F	254287	ADEM
6.	Thomas Poovathur	27/M	255465	Reprising Multiple Sclerosis
7.	Anil Kumar.T.k	41/M	251843	To R/o R.B.N
8	Firoz	30/M	223980	Right Optic Atrophy
9	Balabhadran.V	54/M	250284	Left Eye Visual Loss
10	Lijo Joseph	18/M	252086	Blindness

## **Brainstem Auditory Evoked Potentials**

BAEP or BAER measures the function of the auditory nerve and auditory pathways in the brain stem. The short latency BAER generally is used for clinical purposes. The test can be performed under sedation or under general anesthesia. Standard broadband click stimulation is used on the ear tested, while the contralateral ear receives masking noise of 30 to 40dB lesser intensity. Monoaural stimulation is used. The click intensity should be 65-70dB above click perception threshold. A repetition rate of about 10Hz should be used.

### Electrode placement

An electrode is placed on each earlobe and at Cz. whether nuclei or tracts, or both, generate the peak latencies is not known. Generators currently are postulated to be as follows:

- . Wave I- Action potential of the cranial nerve (CN) VIII
- . Wave II- Cochlear nucleus (and CN VIII)
- . Wave III- Ipsilateral superior olivary nucleus
- . Wave IV- Nucleus or axons of lateral lemniscus
- . Wave V- Inferior colliculus

Factors influencing peak latencies of BAERs include age, sex, auditory acuity stimulus repetition rate, intensity, and polarity. Rarefaction (ie, earphone diaphragm moves away from the eardrum) produces an increase in wave I amplitude. In severe hearing loss, all wave forms may be delayed, wave I may be absent with waves II though V delayed, or all waveforms may be absent. Note that in patients with hearing loss BAER still can be obtained to assess central conduction time by increasing stimulation intensity.

BAEPs are useful in estimating or aiding in the assessment of hearing loss. The most commonly used method for this is evoked response audiometry. The frequency of stimulation is 50-70Hz, and at least 3 different intensities should be used. Wave V latency shifts are used to estimate the amount of hearing loss.

In children, especially those younger than 2 years, the BAEP can be used to screen those who might benefit from auditory amplification in order to achieve more normal speech and language development. However some children with a normal BAER have abnormal hearing. Kileny showed middle latency abnormalities in some of these cases. The role of BAEP nevertheless is to identify those patients who could benefit from a hearing aid. Obviously with normal BAEP a hearing aid would not be useful to correct the hearing loss. Kern et al studied effects of insulin-induced hypoglycemia on the

auditory brain stem response (ABR) in humans. ABRs were examined in 30 healthy men during euglycemia and after 20 minutes and 50 minutes of steady state hypoglycemia of 2.6mm induced with insulin. Hypoglycemia increased interpeak latencies III-V and I-V, whereas changes in the latency of the wave I are not significant.

#### Technical aspects-

Filter band pass of 100-3000Hz is used. The first 10 ms are averaged, and 2-4000 responses may be averaged. At least 2 separate trails should be performed. The recording montage is at least, and usually, a 2 channel montage- channel 1 is ipsilateral ear to vertex and channel 2 is contralateral ear to vertex. Because of relative vertex positivity, the waveforms are recorded as upward deflections. The normal response is a series of waveforms within a time window of 10ms.

Clinically, the first 5 waves are used, with more significance placed on waves I, III and V. Peak and interpeak latencies are measured, side-to-side differences are calculated, and wave I-V ratios may be used. Audiometry is very helpful and should be done within a reasonable time interval of the BAER. This helps the delineate any hearing loss that might influence the test results. Hearing loss in the 2000 - 4000Hz frequency range is especially important, since it may delay the BAER.

Neonatal BAEP: recording the neonatal BAEP is technically different from recording that of the adults. The skin is very sensitive, and special non-allergic tape should be used to fix the electrode. Collodion or other irritant chemicals are to be avoided. To avoid collapse of the earlobe and obstruction of the auditory canal of the premature babies, the earphone should be held above the ear. The earphone is best held by hand, and recording preferably should be performed with the neonate asleep. This helps reduce the high frequency components of the EEG that might interfere with BAEP recording. Because of the slower response, sweep should be set at 15-20ms and the low frequency cutoff filter at 20-30Hz.

BAEPs predominantly activate the pathways in the brain stem ipsilateral to the side of click stimulation. In particular, mid-upper pontine lesions tend to lead to ipsilateral BAER abnormalities. The structures involved in generation of BAER may be more concerned with sound localization than with hearing itself.

<u>Sl.No</u>	<u>Patient's Name</u>	<u>Age/Sex</u>	<u>Hospital No</u>	<u>Diagnosis</u>
1.	Firoz	30/M	223980	Intrinsic Brainstem Tumour
2.	Sandhya. T	25/F	244725	Multiple Sclerosis
3.	Premaletha. V.P	32/F	252864	Cerebellopontine Angle Tumor
4.	Abhijeet Necker	16/M	254140	Language Development Delay
5.	Rose Mary Francis	19/F	237806	Multiple Sclerosis

## **Somatosensory Evoked Potentials**

Somatosensory evoked potentials (SSEPs) consist of a series of waves that reflect sequential activation of neural structures along the somatosensory pathways following electrical stimulation of peripheral nerves. In clinical practice, SSEPs are elicited typically by stimulation of the median nerve at the wrist, the common peroneal nerve at the knee, and/or the posterior tibial nerve at the ankle and recorded from electrodes placed over the scalp, spine, and peripheral nerves. The dorsal column-lemniscal system is the major anatomical substrate of the SSEPs within the CNS.

SSEPs are used for clinical diagnosis in patients with neurologic disease and for intraoperative monitoring during surgeries that place parts of the somatosensory pathways at risk. Abnormal SSEPs can result from dysfunction at the level of the peripheral nerve, plexus, spinal root, spinal cord, brain stem, thalamocortical projections, or primary somatosensory cortex. Since individuals have multiple parallel afferent somatosensory pathways (e.g., anterior spinothalamic tract, dorsal column tracts within the spinal cord), recordings of SSEPs can be normal even in patients with significant sensory deficits.

SSEPs depend on the functional integrity of the fast-conducting, large-diameter group IA muscle afferent fibers and group II cutaneous afferent fibers, which travel in the posterior column of the spinal cord. When a mixed peripheral nerve (with both sensory and motor components) is stimulated, both group IA muscle afferents and group II cutaneous afferents contribute to the resulting SSEP. Selective ablation of the dorsal column of the spinal cord abolishes the SSEPs generated rostral to the lesion. Diseases of the dorsal columns in which joint position sense and proprioception are impaired invariably are associated with abnormal SSEPs.

### **Stimulus Location**

For recording median nerve SSEPs, the nerve is stimulated at the wrist. The anode is placed just proximal to the palmar crease, and the cathode is placed between the tendons of the palmaris longus muscle, 3 cm proximal to the anode.

Ulnar nerve SSEPs are preferred to median nerve SSEPs for assessing the lower cervical spinal cord segment since the ulnar nerve originates from spinal roots C8-T1, whereas the median nerve originates from C6-T1.

For recording posterior tibial nerve SSEPs, the nerve is stimulated at the ankle, with the cathode midway between the Achilles tendon and the medial malleolus and the anode 3 cm distal to the cathode.

For recording peroneal nerve SSEPs, the common peroneal nerve is stimulated at the knee, with the cathode inferior to the leg crease just medial to the tendon of the biceps femoris muscle and the anode 3 cm distal to the cathode.

In the lower limb, posterior tibial SSEPs are preferred because of the following:

- In clinical diagnostic use, they are larger and less subject to variability.
- In intraoperative settings, they produce smaller muscle contractions with larger SSEP amplitudes.
- In intraoperative settings, electrodes at the ankle are more easily accessible than those at the knee. The peripheral compound action potential (CAP) is recorded easily at the popliteal fossa.

### **Stimulus Intensity**

The selected nerves are stimulated with monophasic square pulses, 100-300 microseconds in duration. Stimuli are delivered by using either a constant voltage or a constant current stimulator.

The contact impedances of the stimulating electrodes should be kept low for the following reasons:

- To minimize patient discomfort
- For more effective nerve stimulation, if a constant voltage stimulator is used

To avoid electrical artifacts with constant current stimulation in the clinical setting, the stimulus intensity is set high enough to produce a consistent muscle twitch, which usually is tolerable to the patient. Because the patient is anesthetized during intraoperative SSEP monitoring, higher stimulus intensities can be used and are advisable

to provide a safety margin in case the efficacy of nerve stimulation decreases during surgery.

### **Stimulus Rate**

Rapid stimulus delivery rates should be avoided, as they degrade the waveforms of SSEPs. In clinical settings, a rate of 3-6 stimuli per second usually is used. Rates that are exact subharmonics of 50 Hz (eg, 5Hz) should be avoided, since their use would lead to contamination of the mean SSEPs by large artifacts of 50-Hz line frequency. SSEPs typically are recorded by using standard EEG electrodes affixed with tape or collodion; electrode caps containing multiple recording electrodes also can be used. Scalp needle electrodes are not used routinely because of their high impedance, risk of infection, and discomfort to the patient.

Recording electrode impedances should be kept below 5000 ohms and should be as uniform as possible across the electrodes to maximize common-mode rejection and minimize noise pickup. Also, placing the ground electrodes on the stimulated limb helps reduce the electrical stimulant artifact.

Typical recording amplifier filter settings for SSEPs are 30-3000 Hz. Diagnostic SSEP studies should be performed using the same filter settings used to record normative data.

Several characteristics of SSEPs can be measured, including onset latency, interpeak latency, morphology (i.e., presence and absence of components), and dispersion. Onset latency is the easiest SSEP feature to measure and standardize, but it gives rather limited information. Other characteristics (i.e., morphology and dispersion) are more variable and difficult to interpret.

Absolute SSEP latencies vary with limb length. Interpeak (i.e., transit) times are reliable parameters that are independent of limb length and usually independent of peripheral nerve disease. Aging is associated with some prolongation of SSEP latencies. Latencies are considered abnormal when they are more than 3 standard deviations above the mean of the normative data.

### **Recording electrodes sites**

Anatomical landmarks identify recording electrode sites. Those on the head are defined using the international 10-20 systems, or its extension, the 10-10 systems. Electrode CP3 is midway between C3 and P3, and electrode CP4 is midway between C4 and P4. CPi denotes either CP3 or CP4, whichever is ipsilateral to the stimulated limb; CPc

is the contralateral Centro parietal scalp electrode. CPz is midway between Cz and Pz.

Recording electrodes over the spine are placed in the midline, and they are labeled with the name of the vertebral body they are placed on followed by the letter S, for example, T10S.

Recording montages for cortical SSEP components are either cephalic bipolar, in which both electrodes are placed over the head, or referential, in which a reference electrode is placed at a noncephalic site. Cephalic bipolar montages have the advantage of being relatively free from noise and are preferred for routine clinical use.

For upper limb SSEP studies, electrodes are placed over the Erb point (i.e., the angle between the clavicular head of the sternocleidomastoid muscle and the clavicle), both ipsilateral and contralateral to the stimulus (labeled Epi and Epc). For lower limb SSEP studies, IC denotes an electrode placed over iliac crest.

### **Spinal SSEP**

Electrodes placed over the spine as described above record spinal SSEPs. They are considerably smaller in amplitude than SSEPs recorded over the scalp. However, the difference in latency between the scalp and the cervical or limb SSEPs is a measure of central sensory conduction, assessment of which remains the chief clinical goal of recording SSEPs. Thoracolumbar spinal SSEPs are even smaller than cervical spinal SSEPs and can be difficult to record in obese subjects. SSEP components typically are named by their polarity and typical peak latency in the normal population. For example, N20 is a negativity that typically peaks at 20 milliseconds after the stimulus. The normal latency value for a component in a particular individual may be different from that implied by the component's name, because the lengths of the peripheral nerve and spinal conduction pathways, which vary with the patient's stature and age, influence the latencies of the SSEP components.

The nomenclature of an evoked-potential component is inconsistent in the literature because the recording montage is not specified with the peak latency and polarity. For example, a CPI-Epc linkage following median nerve stimulation records a P14, while an Epc-CPi linkage records an N14.

<u>Sl.No</u>	<u>Patient's Name</u>	<u>Age/Sex</u>	<u>Hospital No</u>	<u>Diagnosis</u>
1.	Sana.M.Varghese	14/F	229021	Multiple Sclerosis
2.	Abraham.K.J	39/M	237359	Peripheral Neuropathy.
3.	Mujeeb Rahman.	16/M	238260	Progressive Myoclonic Epilepsy
4.	Nandana	4/F	240486	M.E.R.R.F
5.	Ambely Alex	25/F	244164	Vasculitis
6.	Abhiram.K.V	14/M	238519	Progressive Myoclonic Epilepsy
7.	Harihara. J	5/M	240810	To Rlo Neuropathy
8.	Ashida .R	6/F	249553	Myoclonic Epilepsy
9.	Charles. J	23/M	251623	To Rlo Poly Neuropathy
10.	Nasim Mohammed	18/M	251604	Progressive Myoclonic Epilepsy Syndrome.

## **Motor Evoked Potentials**

Noninvasive elicitation of motor evoked potentials (MEPs) was made possible by Merton and Morton in 1980. They designed a high-voltage transcranial electrical stimulator that excited the motor cortex using cutaneous electrodes, which were placed over the scalp. After transcranial electrical stimulation (TES), a contraction of contralateral muscles is recorded in a conscious subject.

The usefulness of this method has remained limited by the local discomfort of the electrical currents that are applied over the scalp. An exception to this limitation is its use for intraoperative monitoring.

The development of transcranial magnetic stimulation (TMS) in 1985 opened new possibilities for MEP studies. Barker et al created a new type of cortical magnetic stimulator, based on the principle of electromagnetic induction. The device was composed of a main unit, which contains a bank of heavy-duty capacitors; the hand-held part was freely movable so that it could be placed over any part of the body. Although magnetic stimulation was used first to stimulate the peripheral nervous system (PNS) and muscles, cortical stimulation has become the focus of many studies.

### **Motor Cortex**

The main motor cortical area is located on the anterior wall of the central sulcus and the adjacent portion of the precentral gyrus. This area corresponds to area 4 of Brodmann. It is rich in pyramidal neurons, which provide the anatomical substrates for the motor output function of area 4.

Electrical stimuli over area 4 produce activation of contralateral muscles; the face, mouth, and hand muscles occupy about two thirds of the primary motor area. The size of cortical representation of muscles is less a function of the muscle mass than of precision of the muscle movements. Secondary and tertiary areas of motor function can be mapped roughly around the primary motor cortex.

The primary motor cortex contributes more fibers to the corticospinal tract than any other region. Numerous observations support

contributions from several other areas, including the frontal and parietal cortices. Ipsilateral projections are far less numerous than contralateral, estimated between 1.8-5.9% of corticospinal connections.

### **Pyramidal tract**

Fibers of the corticospinal tract and corticobulbar tract originate from the sensorimotor cortex around the central sulcus. The human pyramidal tract contains over 1 million fibers. Most fibers are myelinated and have a small diameter (1-4 mm); only a small portion (3-5%) are large-diameter fibers (10-22 mm) that originate in Betz cells from area 4.

In humans, only 5% of the fibers of the corticospinal tract originate from Betz cells in area 4. The concept of pyramidal pathways with fibers originating only from Betz cells in the primary motor cortex has been invalidated. A large part of the corticospinal neurons have nonmotor function, especially those originating in sensory or associative areas.

### **Sub cortical projections of the pyramidal pathway**

Pyramidal fibers converge into the corona radiata toward the posterior arm of the internal capsule. In the pons, they divide into multiple longitudinal pathways, which merge in the medulla oblongata to form the pyramidal tract after branching out efferences to motor nuclei of cranial nerves. At the junction between the medulla oblongata and the spinal cord, 75-90% of the fibers cross through the midline to constitute the crossed (i.e., indirect) pyramidal pathway. The remaining fibers comprise the uncrossed (i.e., direct) pyramidal pathway. A large part of direct pyramidal tract fibers actually cross the midline at the spinal cord level (i.e., through the white anterior commissura), so that its projections are bilateral.

### **Magnetic Stimulation**

Magnetic stimulation of the nervous system can occur only in the setting of a rapidly changing magnetic field. Subjects exposed to a constant field strength (e.g., magnetic resonance imaging [MRI]) do not experience stimulation of nervous tissue. The intensity of the secondarily produced electrical field in nervous tissue (and of the

stimulation) is related to the speed of change in magnetic field strength.

Formation of the magnetic pulse starts within the main unit of the stimulator, where a large bank of heavy-duty capacitors is electrically charged. When triggered, these capacitors rapidly discharge through a cable into the hand-held coil, producing a brief burst of high current (up to 4000 volts [V] or several 1000 amperes [A]). The current that moves through the hand-held coil produces a large magnetic field (1-3 T) that lasts only 50-200 milliseconds.

The stimulating coil consists of tightly wound and well-insulated copper coil. As a result of the brief magnetic field induced from the coil, a secondary electric field that circulates in the opposite direction to the magnetic field is produced. The strength of the electric field is related in part to the first derivative of the magnetic flux over time: the more rapid the change in magnetic field, the stronger the intensity of the secondary electric field and nervous stimulation.

Most commercially available stimulators can produce stimulations at a rate as high as 5 Hz, although some can produce repetitive stimulations as high as 50 Hz. A big advantage of magnetic stimulation over electrical stimulation is its ability to penetrate tissues regardless of electrical resistance. The drop-off is essentially the same for air, bone, fat, muscle, and saline.

The magnitude, waveform, and rise time of the magnetic field are important parameters of the stimulation. The diameter, shape, and thickness of the coil are also important. Because of these multiple variables, the measurement of intensity of stimulation usually is expressed as a percentage of the maximal output of the stimulator.

In choosing coils, the trade-off is between strength and focality of stimulation. Coil diameter may vary between 5 cm and 15 cm. Large-diameter coils stimulate over a wider area but are less focal than small-diameter coils. With the round coils, the highest intensity electric field is measured at the edges of the coil with lower intensities in the center. To obtain more focality, use of a butterfly (also called "figure of 8" coil) is recommended. Their focality makes them particularly suitable for the performance of mapping out the upper limb and hand musculature.

## **Electrical Stimulation**

Electrical stimulators have a simpler design than magnetic stimulators. The stimulation is transmitted through cutaneous electrodes. The main advantage is a better depth of penetration, allowing direct spinal cord stimulation. The main limitation is the local discomfort that is created by the stimulation.

Electrical stimulators contain a capacitor that produces constant current, high-voltage pulses of brief duration for percutaneous stimulation. The output current range is 0-1000 milliamperes, from a source voltage as high as 400 V. The pulse width range can be varied from 50 milliseconds to 2 milliseconds. The voltage is kept constant during the stimulation, but the intensity of stimulation depends on the skin impedance.

## **OPTOMETRY**

Optic nerve is the most important nerve which carries visual impulses from the retina to the optic chiasma and on the optic tract to the lateral geniculaters body: to act as the afferent pathway for the papillary light reflex by means of fibres traveling to the superior colliculus of the mid brain.

The major test performed in the optometry is:

- (i) To measure the acuity of vision and to determine if any defect is due to local ocular disease.
- (ii) To chart the visual fields

### **VISUAL ACUITY**

The standard Snellen's Type of charts are used for testing distant vision and the Jaegar types cards for near vision.

The Snellen's type chart is placed, evenly illuminated, 6 metres (20 feet) from the patient, who covers one eye and is asked to read the smallest line he/she can see accurately. Acuity is recorded as a fraction (6/24). The numerator indicates the distance at which the patient has to be from the chart in order to read the same type that the normal person could read at a distance indicated by denominator. 6/5 – 6/6 are within the average normal range.

The Jaegar type card must be held one foot from the patients eye and a similar test is then carried out. The different types are labeled as N6, N24etc according to their size. The average acuity lies between N6 and N9.

### **VISUAL FIELD**

Charting the visual field is the most important method of locating a lesion in the visual pathways or of interpreting certain fundus appearances, yet in clinical notes it is often difficult to find evidence that any attempt has been made to examine them at all. The purpose of the test is to chart the

periphery of the visual fields; to determine the position, size and shape of the blind spot and any abnormal scotomata; to compare any defects shown with those abnormalities known to be reproduced by lesions at specific points in the visual pathways. The principles by which lesions are located are thus illustrated by comparing a diagram of the visual pathways with the principal field defects.

<u>Sl.No</u>	<u>Patient's Name</u>	<u>Age/Sex</u>	<u>Hospital No</u>	<u>Diagnosis</u>
1	Santhosha	40/F	235241	Meningioma
2	Suma.V.N	27/F	234983	left frontal Glioma
3	Venkataraman.S	43/M	9201245	Recurrent Pituitary Adenoma
4	Elizabeth Mathew	51 <sup>26</sup> /F	9710376	I.I.H
5	Karthika	27/F	225778	Pre Opt. ATL
6	Sreemesh.K	19/M	235700	Right Occipital S.O.L
7	Thankam. C	50/F	185543	B.I.H
8	Sindhu.S	19/F	9120605	VI Nerve Palsy
9	Therasammal.C	48/F	233536	C.P. Angle Lesion
10	Sudarsanan	49/M	216683	Post Circulation Stroke

<u>Sl.No</u>	<u>Patient's Name</u>	<u>Age/Sex</u>	<u>Hospital No</u>	<u>Diagnosis</u>
11	Sajith. P	31/M	9604748	CPS - ET
12	Khadeeja .P.V	36/F	235868	Pineal Region Tumor
13	Remya Chandran	20/F	233767	Post Right A.V.M
14	Arundayan. U	18/M	184467	Recurrent Pituitary Adenoma
15	Akhil Prakash	6/M	235229	Occipital Infract
16	Nizar. T. S	45/M	235910	Olfactory Groove Meningioma
17	Shiji. M. P	23/F	223610	Multiple Sclerosis
18	Suresh. M	25/M	235615	Left Parietal Occipital Lesion
19	Ambilca.	47/F	235419	Pituitary Adenoma
20	Latha. P	43/F	234663	Seizure Disorder

<u>Sl.No</u>	<u>Patient's Name</u>	<u>Age/Sex</u>	<u>Hospital No</u>	<u>Diagnosis</u>
21	Asha Thahar	18/F	235776	Suprachiasmatic Tumour
22	Rema. C.K	29/F	198969	C. V. T
23	Amia. V.P	50/F	225355	Pallidotomy
24	Sreedevi	<sup>50</sup> 38/F	236387	H. S. P
25	Sudevan. P	44/M	236481	Young Stroke
26	Joseph Joseph	56/M	181796	Myasthenia
27	Sushamma	50/F	193708	Orbital Apex
28	Radhakrishnan.T	43/M	235577	Cellunoid Cyst
29	Elizabeth Mathew	44/F	9710376	Idiopathic I. C Hypertension
30	Asharaf. A.M	38/F	210839	Left ATL + AH

## **Technologist's role in patient safety**

By deliberately grounding the patient, we subject the patient to the risk of electrical shock into contact with a live voltage or with a current carrying wire. So ensure proper grounding for both the machine and the patient. When an electrical device already connected has a ground of its own on the patient, do not attach an EEG ground to the patient but use the already existing ground instead. Ground loop causes current to flow through the patient's body. If this results in unacceptable high levels of 60/50 Hz artifacts, remove the existing ground lead and replace it with the standard EEG electrode placement usually the center of the patient's forehead. While doing nerve conduction studies and EMG place the ground electrode over the testing limb.